

COUNT	DESCRIPTION OF REVISIONS	BY	CHKD	DATE

RECOMMENDED FPC (FREE)

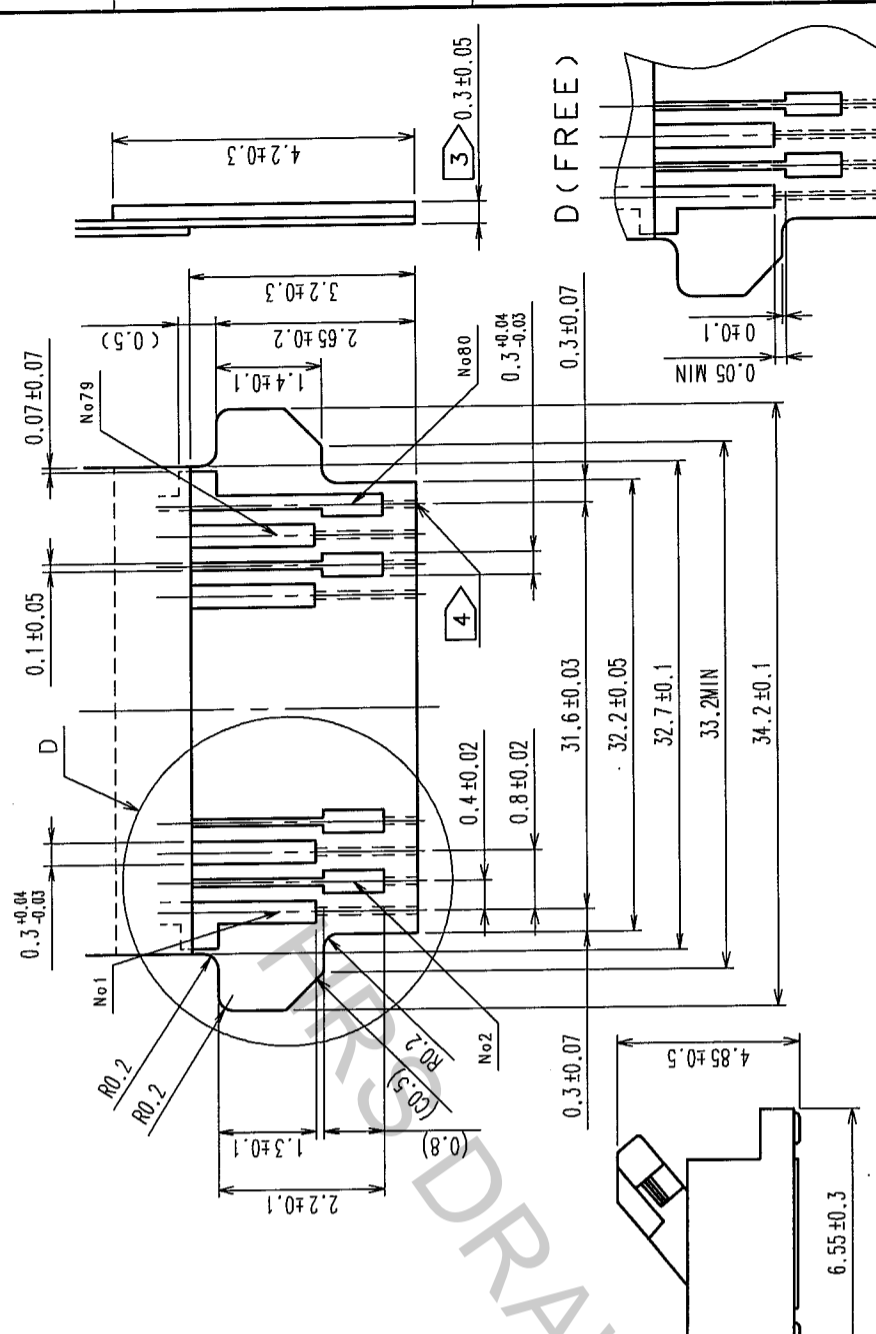

- 注
- 1 DIMENSION FROM REFERENCE C
 - 2 LEAD CO-PLANARITY SHALL BE 0.1MAX.
 - 3 STIFFENER MATERIAL: POLYIMIDE, HEAT CURED ADHESIVE. POLYIMIDE THICKNESS OF STIFFENER SINGLE-SIDED FPC: 0.15mm(6mil)MIN DOUBLE-SIDED FPC: 0.125mm(5mil)MIN CONDUCTOR WIDTH SHALL BE 0.1±0.05 IF FPC HAS PLATING BARS.
 - 4 CROSS SECTION A-A IS FOR EVEN-NUMBER PINS AND CROSS SECTION B-B IS FOR ODD-NUMBER PINS. THE QUALITY REMAINS GOOD, EVEN WITH THE DARK SPOTS, WHICH COULD OCCASIONALLY OCCUR ON MOLDED PLASTIC.

RECOMMENDED LAND PATTERN, METAL MASK (FREE)

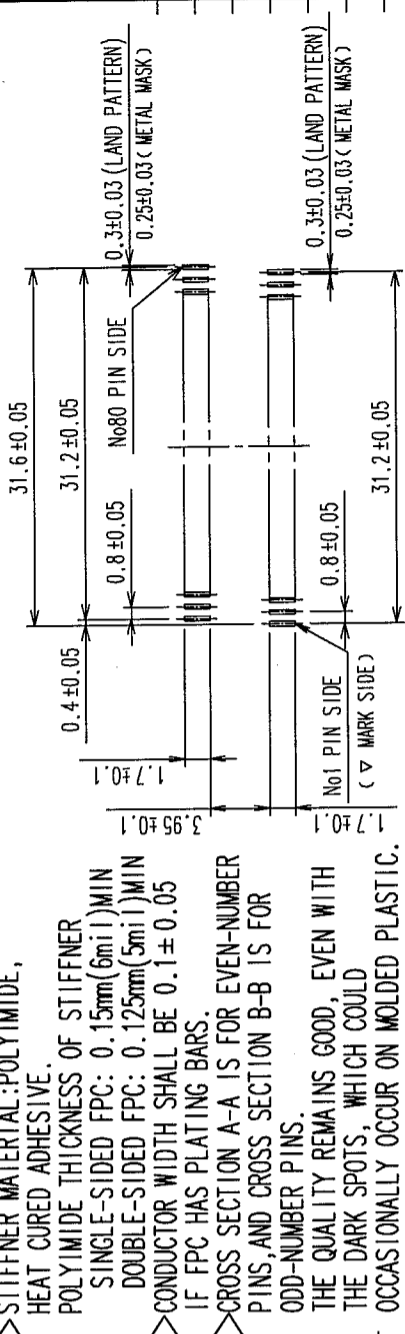

* RECOMMENDED METAL MASK THICKNESS: t=0.15

NO.	MATERIAL	FINISH, REMARKS	NO.	MATERIAL	FINISH, REMARKS
2	LCP (BLACK)	UL94V-0	4	PHOSPHOR BRONZE	GOLD FLASH OVER NICKEL 1μm MIN
1	LCP (BEIGE)	UL94V-0	3	PHOSPHOR BRONZE	GOLD FLASH OVER NICKEL 1μm MIN

CODE NO. (OLD)	CL?	DRAWN	DESIGNED	CHECKED	APPROVED	RELEASED
		Y. Ebi	T. Murai	T. Kuwata	R. Takayanagi	

DATE: 04.10.15

DRAWING NO.	PART NO.
EDC3-155101-01	FH30M-80S-0.4SHW(05)

SCALE	UNITS	CODE NO.
5 : 1	mm	CL580-0102-0-05

TO	
NC	
IDN	

COUNT	DESCRIPTION OF REVISIONS	BY	CHKD	DATE	COUNT	DESCRIPTION OF REVISIONS	BY	CHKD	DATE

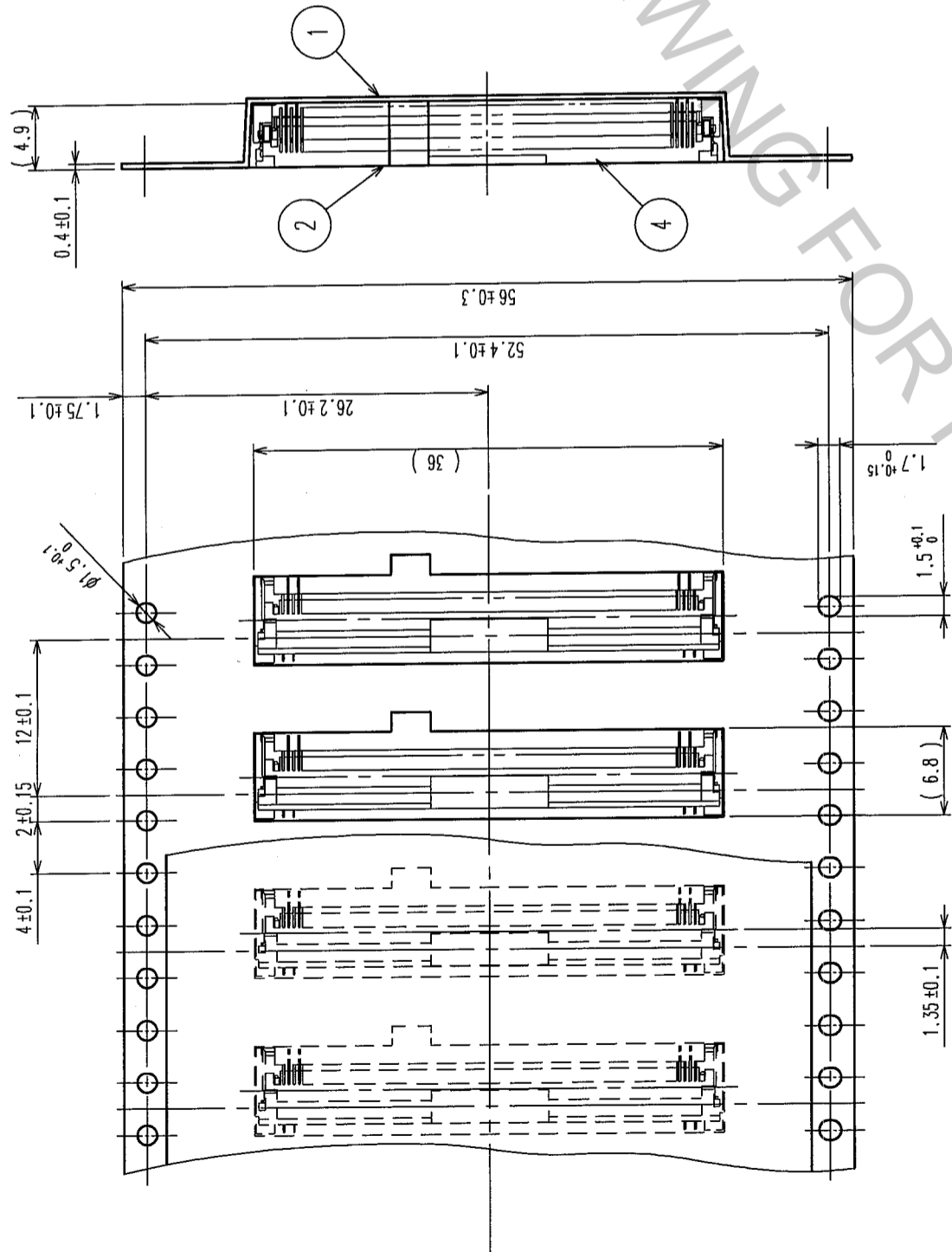

REEL DIMENSION (FREE)

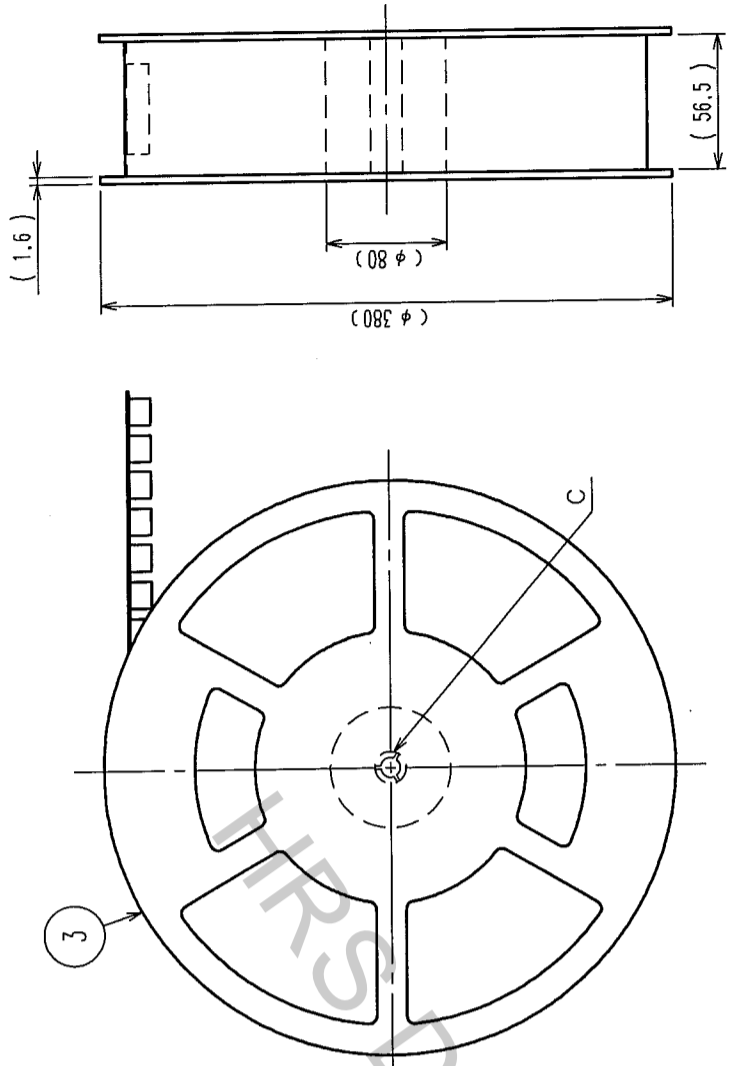

C (1:1)

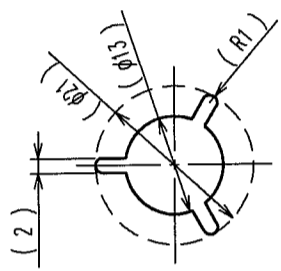

DIRECTION OF UNREELING

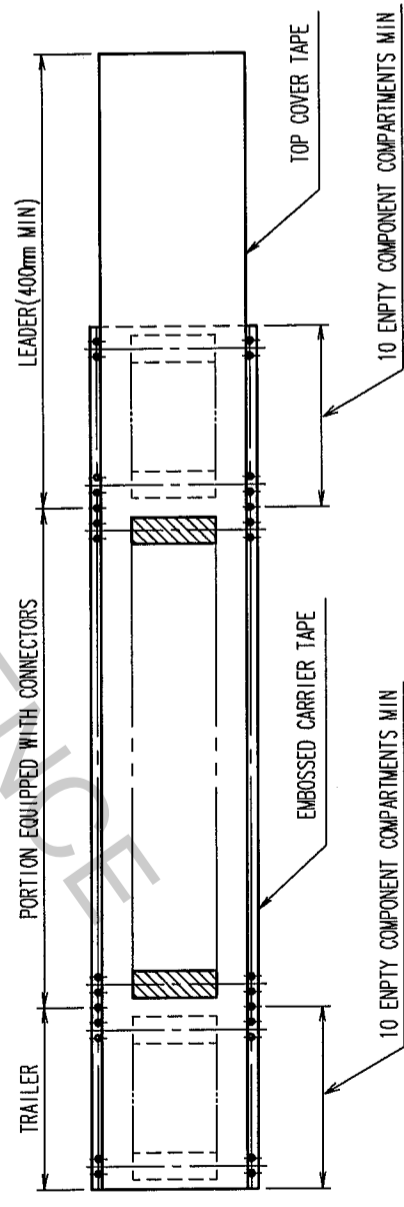

- 注 1 PER REEL : 1000 CONNECTORS.
- 注 2 REFER TO JIS C 0806 (PACKAGING OF COMPONENTS FOR AUTOMATIC HANDLING.)

NO.	MATERIAL	FINISH, REMARKS	NO.	MATERIAL	FINISH, REMARKS
2	POLYESTER		4	(CONNECTOR)	
1	POLYSTYRENE		3	POLYSTYRENE	

CODE NO. (OLD)	CL	DESIGNED	CHECKED	APPROVED	RELEASED
		Y. Ebi	J. Murai	J. Kuwata	R. Takayanagi
		04.10.15	04.10.19	04.10.19	04.10.19

DRAWING NO.	PART NO.
EDC3-155101-01	FH30M-80S-0.4SHW(05)

SCALE	UNITS	CODE NO.
2 : 1	mm	CL580-0102-0-05

TO	NC	IDN
----	----	-----