

**ASSEMBLY INSTRUCTIONS:**

1. PREPARE CABLE ENDS, CONNECT TO CONNECTOR
2. PLACE JACKSCREWS INTO RECESS AREA
3. PLACE RIBBON CABLE IN STRAIN RELIEF CLAMP AREA MAKING SURE CABLE JACKET IS BELOW STRAIN RELIEF
4. PLACE THE OTHER HALVE OF THE HOOD ON TOP OF THE FIRST HALF, MAKING SURE NO WIRES ARE PINCHED
5. TIGHTEN THE TWO HALVES TOGETHER WITH THE HARDWARE PROVIDED

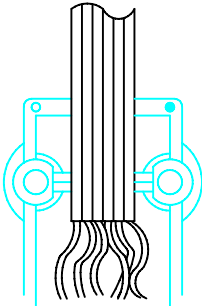
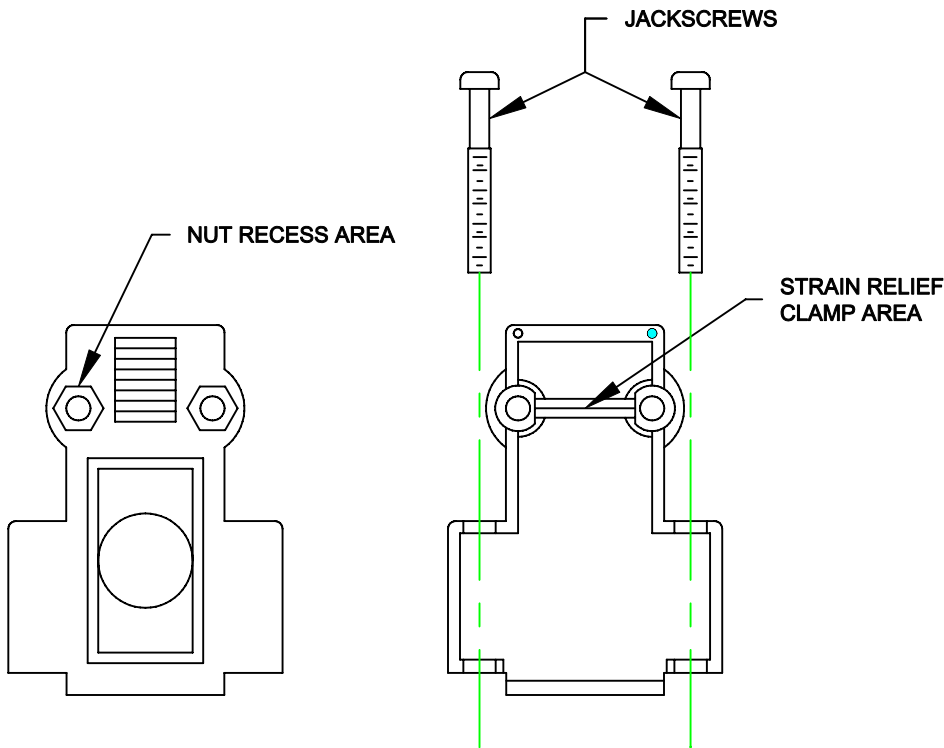

ITEM No. 3

**RoHS COMPLIANT**

**PLASTIC**

	THESE DRAWINGS AND SPECIFICATIONS ARE THE PROPERTY OF NorComp AND SHALL NOT BE REPRODUCED, COPIED OR USED AS THE BASIS FOR THE MANUFACTURE OF SALE OF APPARATUS WITHOUT WRITTEN PERMISSION.		DRAWN: <b>C. SMITH</b>		DATE: <b>03-28-06</b>
			CHECKED: <b>X</b>		DATE: <b>X</b>
<h1>NorComp</h1>			SCALE: <b>N.T.S.</b>	SHEET <b>1</b>	OF <b>2</b>
			DWG NO. <b>BACKSHELL - 976 SERIES</b>		
			REV <b>0</b>		

**ASSEMBLY INSTRUCTIONS:**

1. PREPARE CABLE ENDS, CONNECT TO CONNECTOR
2. PLACE JACKSCREWS INTO RECESS AREA
3. PLACE RIBBON CABLE IN STRAIN RELIEF CLAMP AREA MAKING SURE CABLE JACKET IS BELOW STRAIN RELIEF
4. IF CABLE IS SHIELDED, FOLD SHIELD AND/OR GROUND WIRE BACK OVER CLAMP AREA. CUT ANY EXCESS WIRE SO IT WILL NOT STICK OUT OF HOOD
5. PLACE THE OTHER HALF OF THE HOOD ON TOP OF THE FIRST HALF, MAKING SURE NO WIRES ARE PINCHED
6. TIGHTEN THE TWO HALVES TOGETHER WITH THE HARDWARE PROVIDED

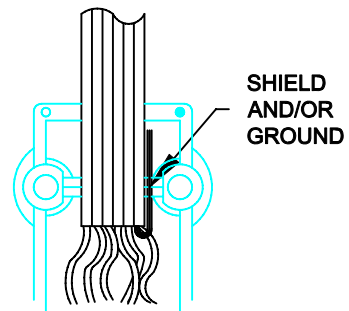
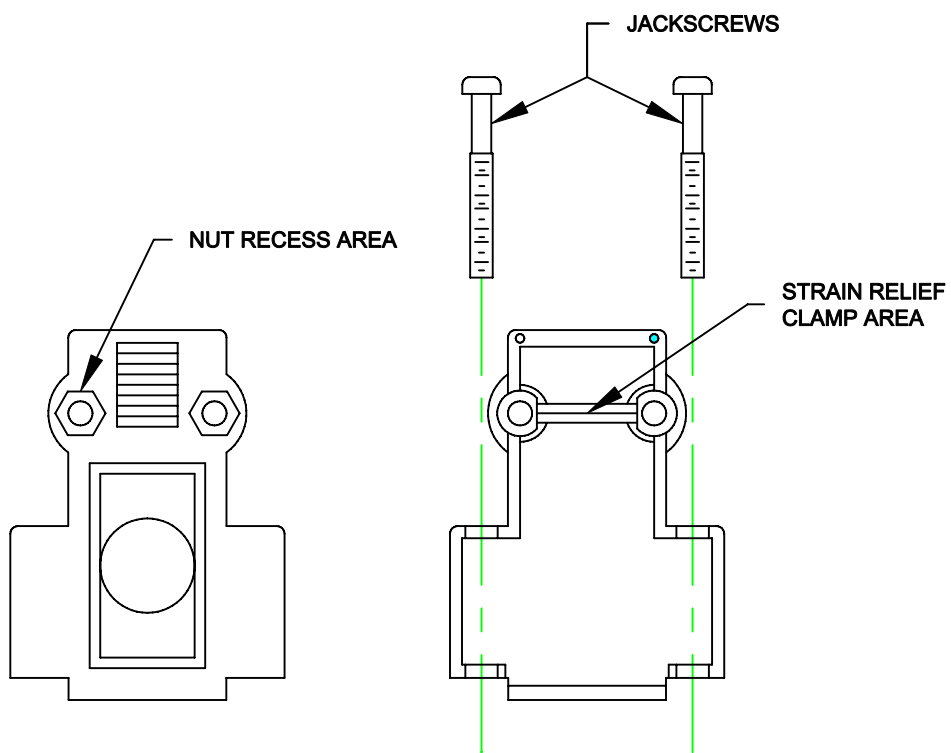

ITEM No. 3 & 4

**RoHS COMPLIANT**

**METALIZED PLASTIC**

	THESE DRAWINGS AND SPECIFICATIONS ARE THE PROPERTY OF NorComp AND SHALL NOT BE REPRODUCED, COPIED OR USED AS THE BASIS FOR THE MANUFACTURE OF SALE OF APPARATUS WITHOUT WRITTEN PERMISSION.		DRAWN: <b>C. SMITH</b>	DATE: <b>03-28-06</b>
			CHECKED: <b>X</b>	DATE: <b>X</b>
NorComp	SCALE: <b>N.T.S.</b>	SHEET <b>2</b> OF <b>2</b>	REV <b>0</b>	
	DWG NO. <b>BACKSHELL - 976 SERIES</b>			