

650V Cascode GaN FET PQFN88 Series

Description

The TPH3208L Series 650V, 110mΩ gallium nitride (GaN) FETs are normally-off devices. Transphorm GaN FETs offer better efficiency through lower gate charge, faster switching speeds, and smaller reverse recovery charge, delivering significant advantages over traditional silicon (Si) devices.

Transphorm is a leading-edge wide band gap supplier with world-class innovation and a portfolio of fully-qualified GaN transistors that enables increased performance and reduced overall system size and cost.

Related Literature

- [AN0009](#): Recommended External Circuitry for GaN FETs
- [AN0003](#): Printed Circuit Board Layout and Probing

Product Series and Ordering Information

Part Number*	Package	Package Configuration
TPH3208LD	8 x 8mm PQFN	Common Drain
TPH3208LDG**	8 x 8mm PQFN	Common Drain
TPH3208LS	8 x 8mm PQFN	Common Source

* Add "-TR" suffix for tape and reel
 ** LDG package offers larger gate pad

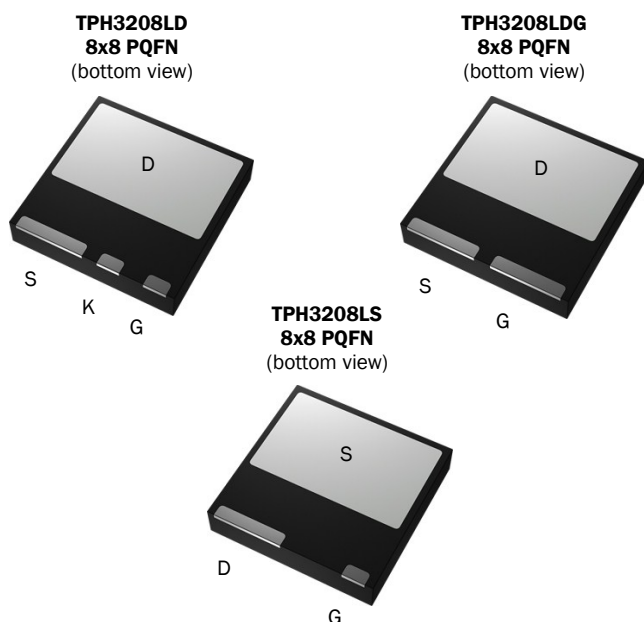

Features

- Easy to drive—compatible with standard gate drivers
- Low conduction and switching losses
- Low Q_{rr} of 54nC—no free-wheeling diode required
- JEDEC-qualified GaN technology
- RoHS compliant and Halogen-free

Benefits

- Increased efficiency through fast switching
- Increased power density
- Reduced system size and weight
- Enables more efficient topologies—easy to implement bridgeless totem-pole designs
- Lower BOM cost

Applications

- Renewable energy
- Industrial
- Automotive
- Telecom and datacom
- Servo motors

Key Specifications	
V_{DS} (V) min	650
V_{TDS} (V) max	800
$R_{DS(on)}$ (mΩ) max*	130
Q_{rr} (nC) typ	54
Q_g (nC) typ	10

* Includes dynamic $R_{(on)}$

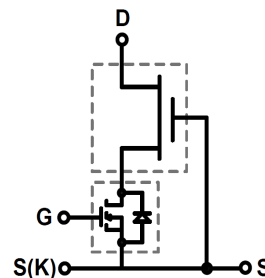

Cascode Device Structure

TPH3208L Series

Absolute Maximum Ratings ($T_C=25^\circ\text{C}$ unless otherwise stated)

Symbol	Parameter	Limit Value	Unit
$I_{D25^\circ\text{C}}$	Continuous drain current @ $T_C=25^\circ\text{C}$ ^a	20	A
$I_{D100^\circ\text{C}}$	Continuous drain current @ $T_C=100^\circ\text{C}$ ^a	13	A
I_{DM}	Pulsed drain current (pulse width: 10 μs)	80	A
V_{DSS}	Drain to source voltage	650	V
V_{TDS}	Transient drain to source voltage ^b	800	V
V_{GSS}	Gate to source voltage	± 18	V
$P_{D25^\circ\text{C}}$	Maximum power dissipation	96	W
T_C	Operating temperature	Case	-55 to +150
T_J		Junction	-55 to +150
T_S	Storage temperature	-55 to +150	$^\circ\text{C}$
T_{CSOLD}	Soldering peak temperature ^c	260	$^\circ\text{C}$

Thermal Resistance

Symbol	Parameter	Typical	Unit
$R_{\theta JC}$	Junction-to-case	1.3	$^\circ\text{C}/\text{W}$
$R_{\theta JA}$	Junction-to-ambient ^d	45	$^\circ\text{C}/\text{W}$

Notes:

- For high current operation, see application note AN0009
- In off-state, spike duty cycle $D < 0.01$, spike duration $< 1\mu\text{s}$
- For 10 sec., 1.6mm from the case
- Device on one layer epoxy PCB for drain connection (vertical and without air stream cooling, with 6cm² copper area and 70 μm thickness)

TPH3208L Series

Electrical Characteristics (T_C=25 °C unless otherwise stated)

Symbol	Parameter	Min	Typ	Max	Unit	Test Conditions
Static						
V _{DSS-MAX}	Maximum drain-source voltage	650	—	—	V	V _{GS} =0V
V _{GS(th)}	Gate threshold voltage	1.6	2.1	2.6	V	V _{DS} =V _{GS} , I _D =0.3mA
R _{DS(on)}	Drain-source on-resistance (T _J =25 °C)	—	110	130	mΩ	V _{GS} =8V, I _D =14A, T _J =25 °C
	Drain-source on-resistance (T _J =150 °C)	—	226	—		V _{GS} =8V, I _D =14A, T _J =150 °C
I _{DSS}	Drain-to-source leakage current (T _J =25 °C)	—	3	30	μA	V _{DS} =650V, V _{GS} =0V, T _J =25 °C
	Drain-to-source leakage current (T _J =150 °C)	—	7	—		V _{DS} =650V, V _{GS} =0V, T _J =150 °C
I _{GSS}	Drain-to-source forward leakage current	—	—	100	nA	V _{GS} =18V
	Drain-to-source reverse leakage current	—	—	-100		V _{GS} =-18V
Dynamic						
C _{ISS}	Input capacitance	—	760	—	pF	V _{GS} =0V, V _{DS} =400V, f=1MHz
C _{OSS}	Output capacitance	—	58	—		
C _{RSS}	Reverse transfer capacitance	—	6	—		
C _{O(er)}	Output capacitance, energy related ^a	—	82	—	pF	V _{GS} =0V, V _{DS} =0V to 400V
C _{O(tr)}	Output capacitance, time related ^b	—	132	—		
Q _g	Total gate charge	—	10	42	nC	V _{DS} =400V, V _{GS} =0V to 8V, I _D =13A
Q _{gs}	Gate-source charge	—	3.1	—		
Q _{gd}	Gate-drain charge	—	3.4	—		
t _{d(on)}	Turn-on delay	—	17	—	ns	V _{DS} =400V, V _{GS} =0V to 10V, I _D =13A, FB=120Ω
t _r	Rise time	—	7	—		
T _{d(off)}	Turn-off delay	—	23	—		
t _f	Fall time	—	8	—		
Reverse Operation						
I _S	Reverse current	—	—	13	A	V _{GS} =0V, T _C =100 °C
V _{SD}	Reverse voltage	—	1.93	—	V	V _{GS} =0V, I _S =14A, T _J =25 °C
		—	1.33	—		V _{GS} =0V, I _S =7A, T _J =25 °C
t _{rr}	Reverse recovery time	—	22	—	ns	I _S =0A to 13A, V _{DD} =400V, di/dt=1000A/μs, T _J =25 °C
Q _{rr}	Reverse recovery charge	—	54	—	nC	

Notes:

- Equivalent capacitance to give same stored energy from 0V to 400V
- Equivalent capacitance to give same charging time from 0V to 400V

TPH3208L Series

Typical Characteristics (25 °C unless otherwise stated)

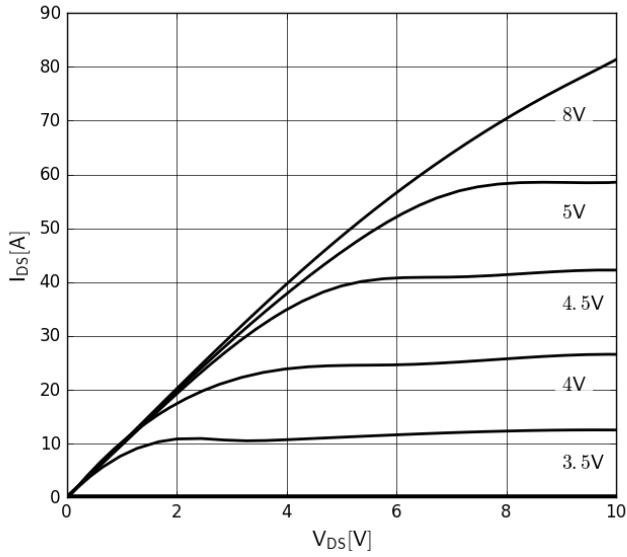

Figure 1. Typical Output Characteristics $T_J=25\text{ }^\circ\text{C}$
Parameter: V_{GS}

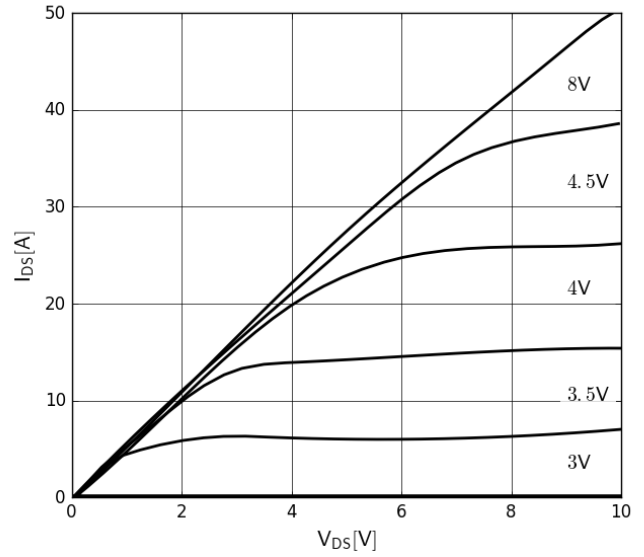

Figure 2. Typical Output Characteristics $T_J=150\text{ }^\circ\text{C}$
Parameter: V_{GS}

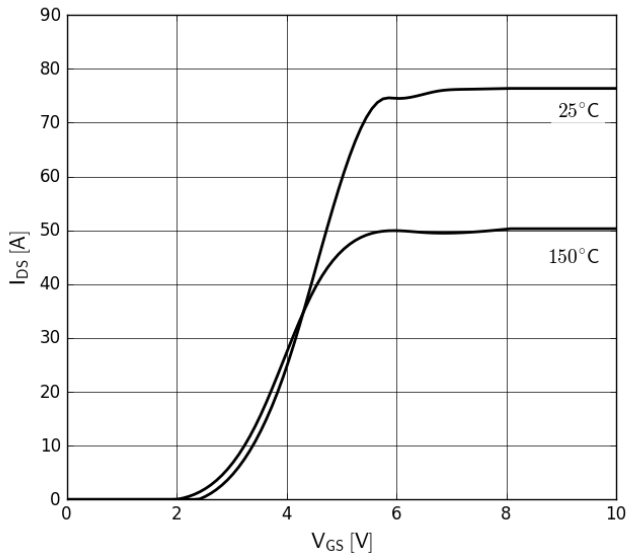

Figure 3. Typical Transfer Characteristics
 $V_{DS}=10\text{V}$, parameter: T_J

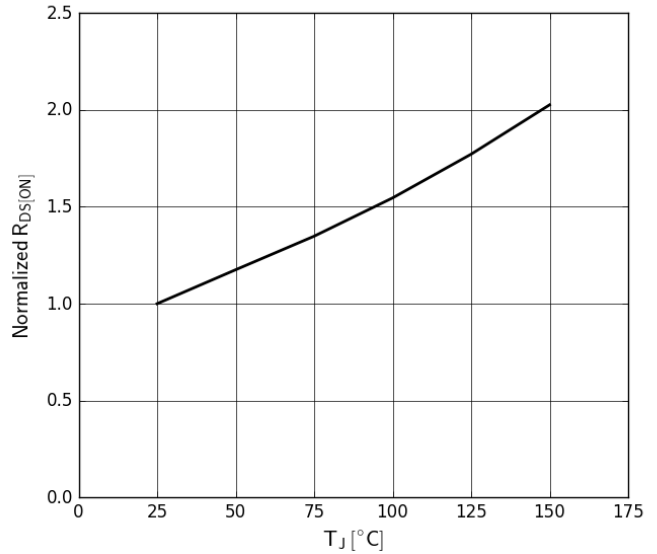

Figure 4. Normalized On-Resistance
 $I_D=13\text{A}$, $V_{GS}=8\text{V}$

TPH3208L Series

Typical Characteristics (25 °C unless otherwise stated)

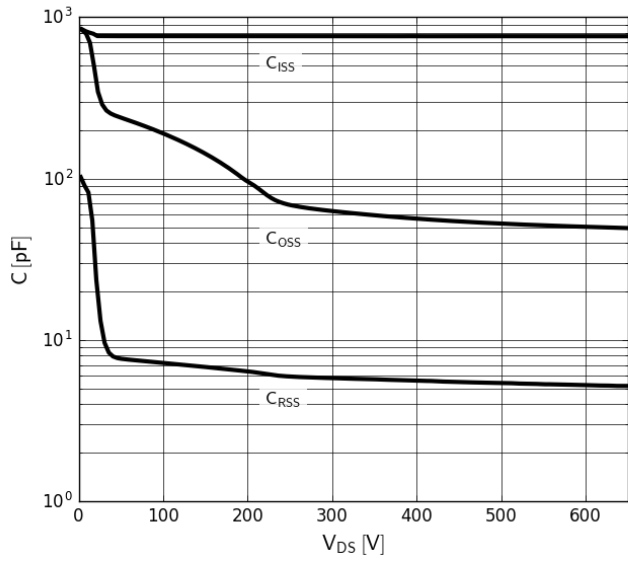

Figure 5. Typical Capacitance

$V_{GS}=0V, f=1MHz$

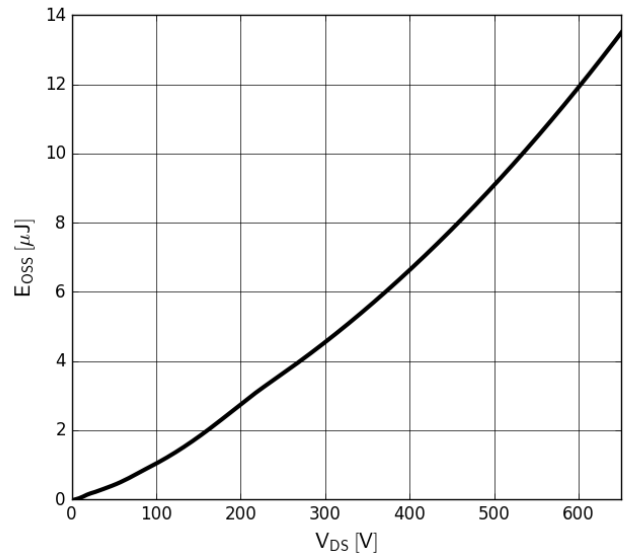

Figure 6. Typical Coss Stored Energy

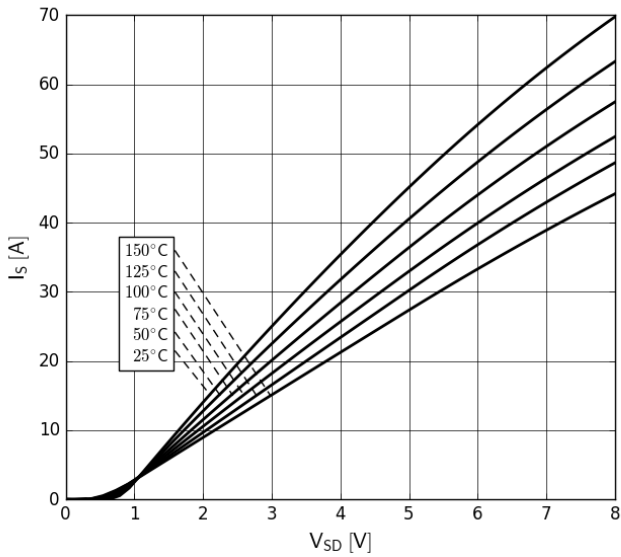

Figure 7. Forward Characteristics of Rev. Diode

$I_s=f(V_{SD}),$ parameter: T_J

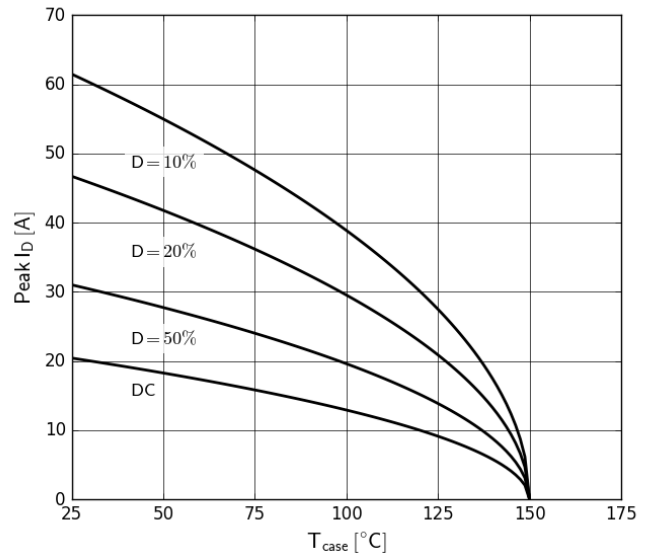

Figure 8. Current Derating

Pulse width $\leq 10\mu s$

TPH3208L Series

Typical Characteristics (25 °C unless otherwise stated)

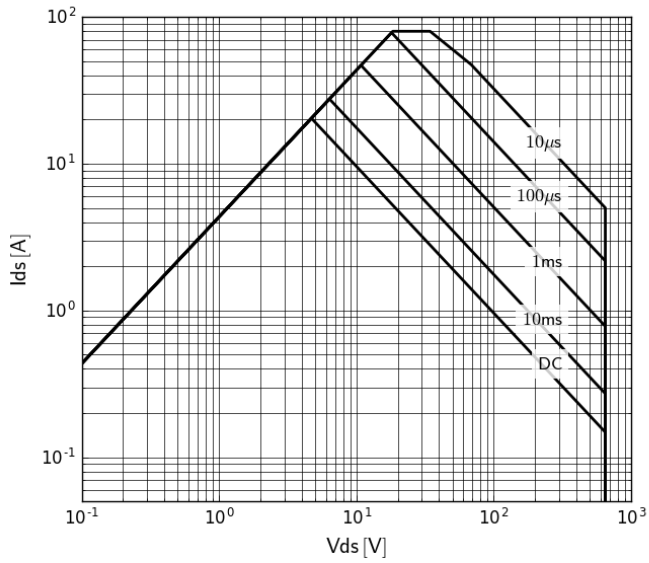

Figure 9. Safe Operating Area $T_c=25^\circ\text{C}$

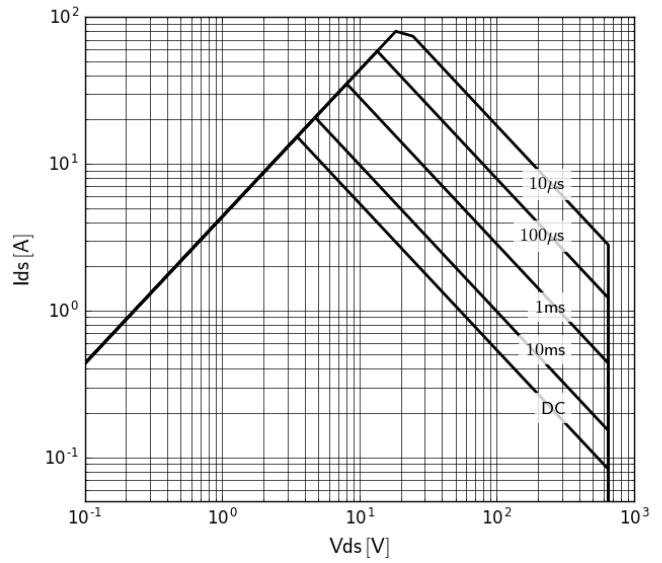

Figure 10. Safe Operating Area $T_c=80^\circ\text{C}$

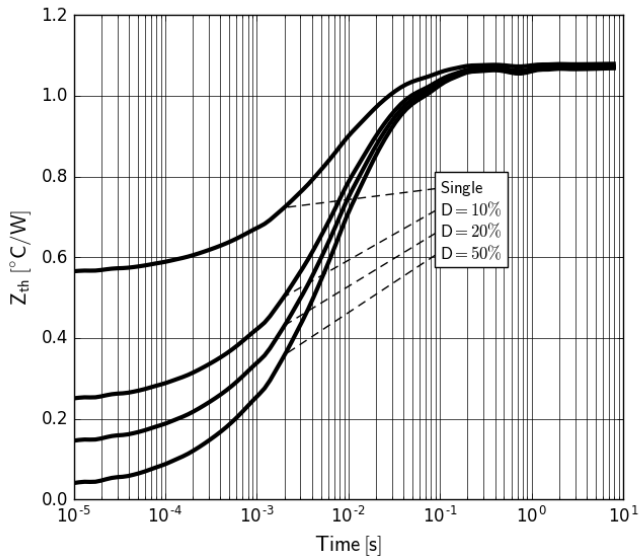

Figure 11. Transient Thermal Resistance

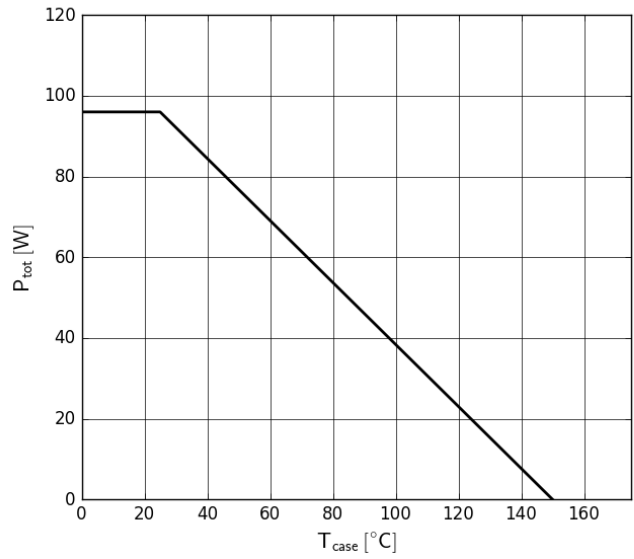

Figure 12. Power Dissipation

TPH3208L Series

Test Circuits and Waveforms

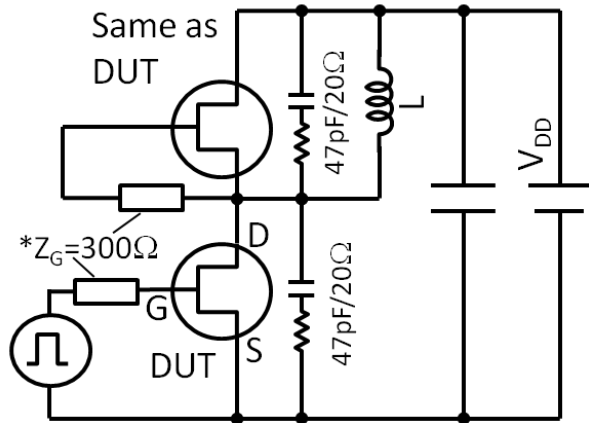

Figure 13. Switching Time Test Circuit
 *ferrite bead 300Ω at 100MHz
 (See app note AN0009 for methods to ensure clean switching)

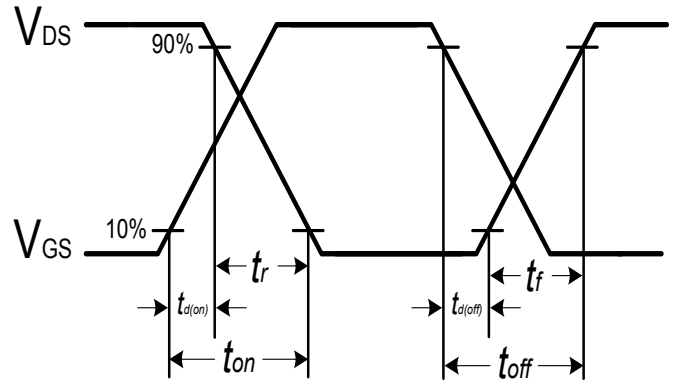

Figure 14. Switching Time Waveform

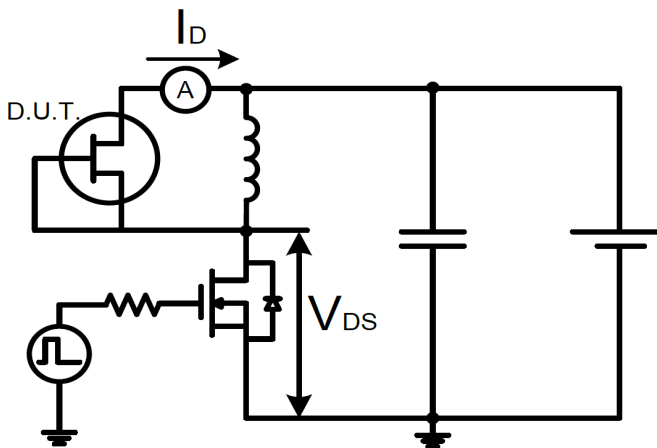

Figure 15. Test Circuit for Reverse Diode Characteristics

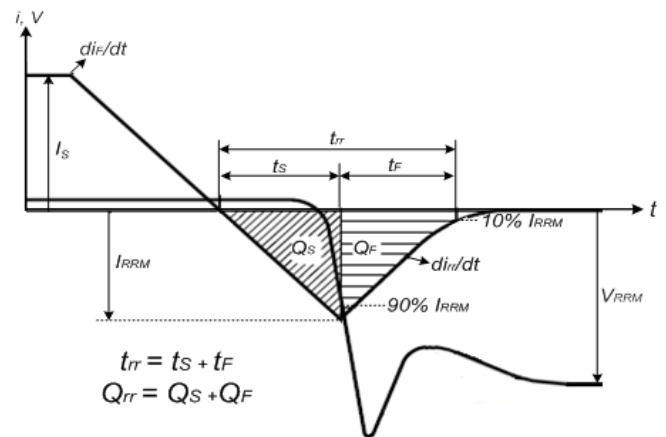
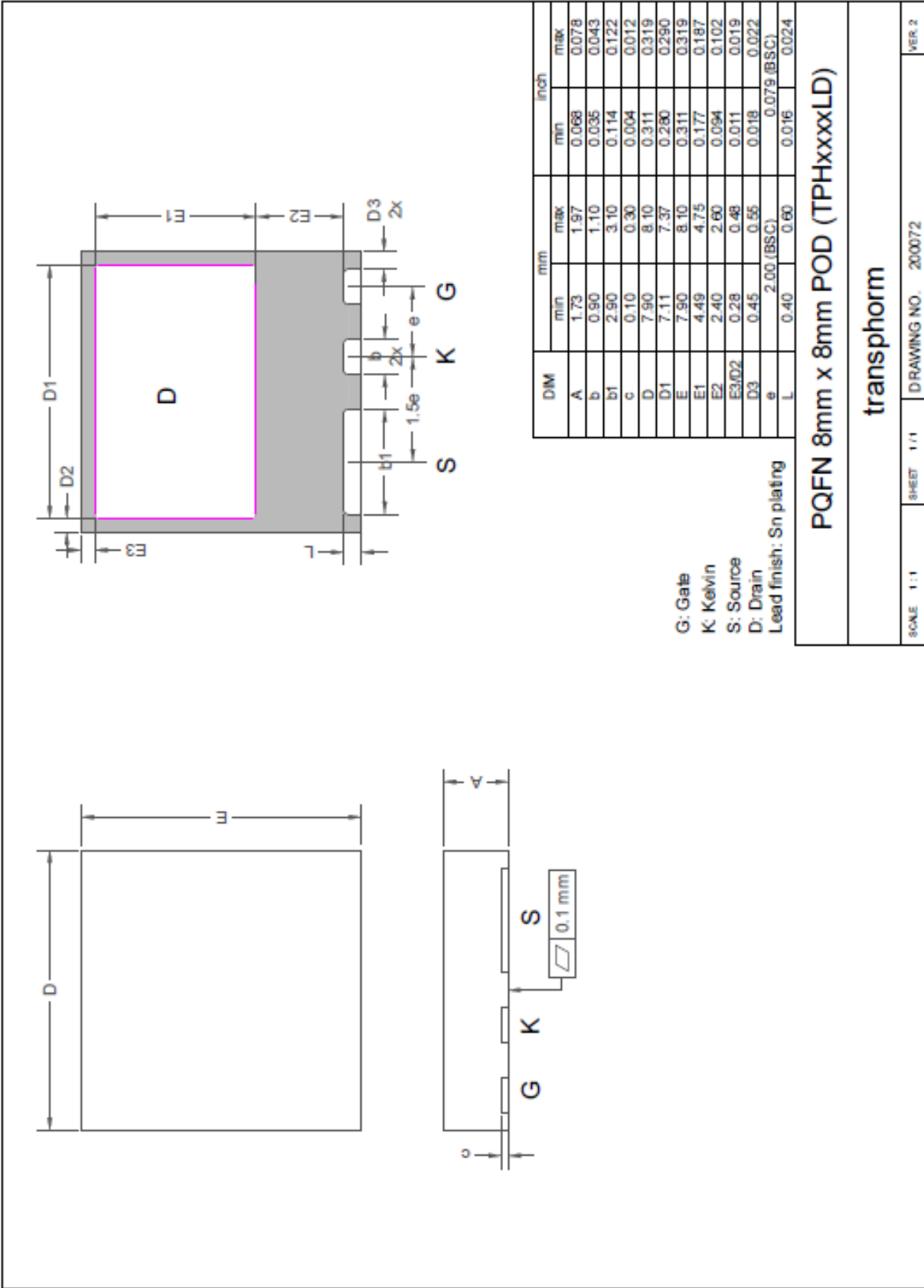

Figure 16. Diode Recovery Waveform

TPH3208L Series

Mechanical

8x8 PQFN (LD) Package



TPH3208L Series

Mechanical

8x8 PQFN (LDG) Package

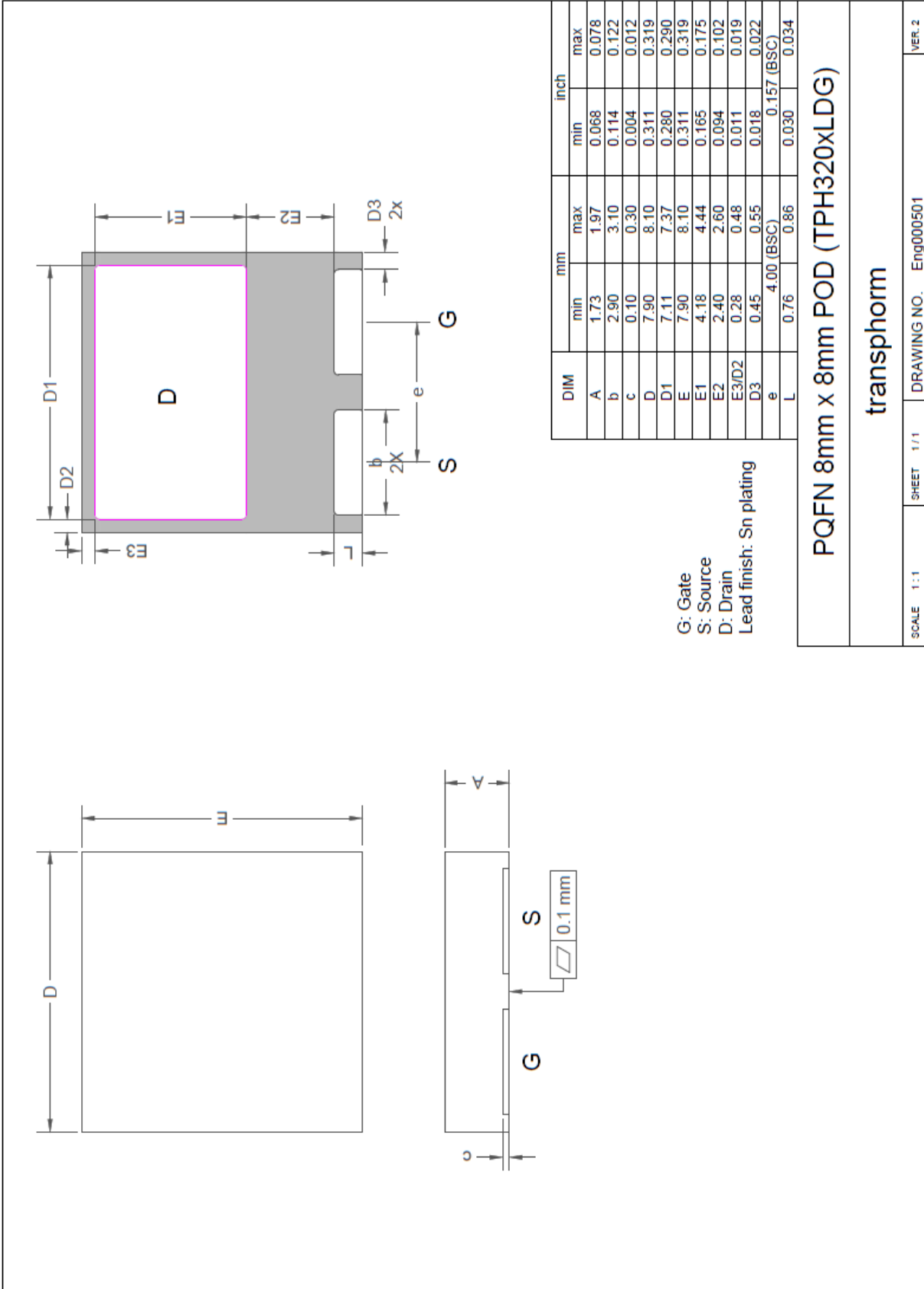

TPH3208L Series

Mechanical

8x8 PQFN (LS) Package

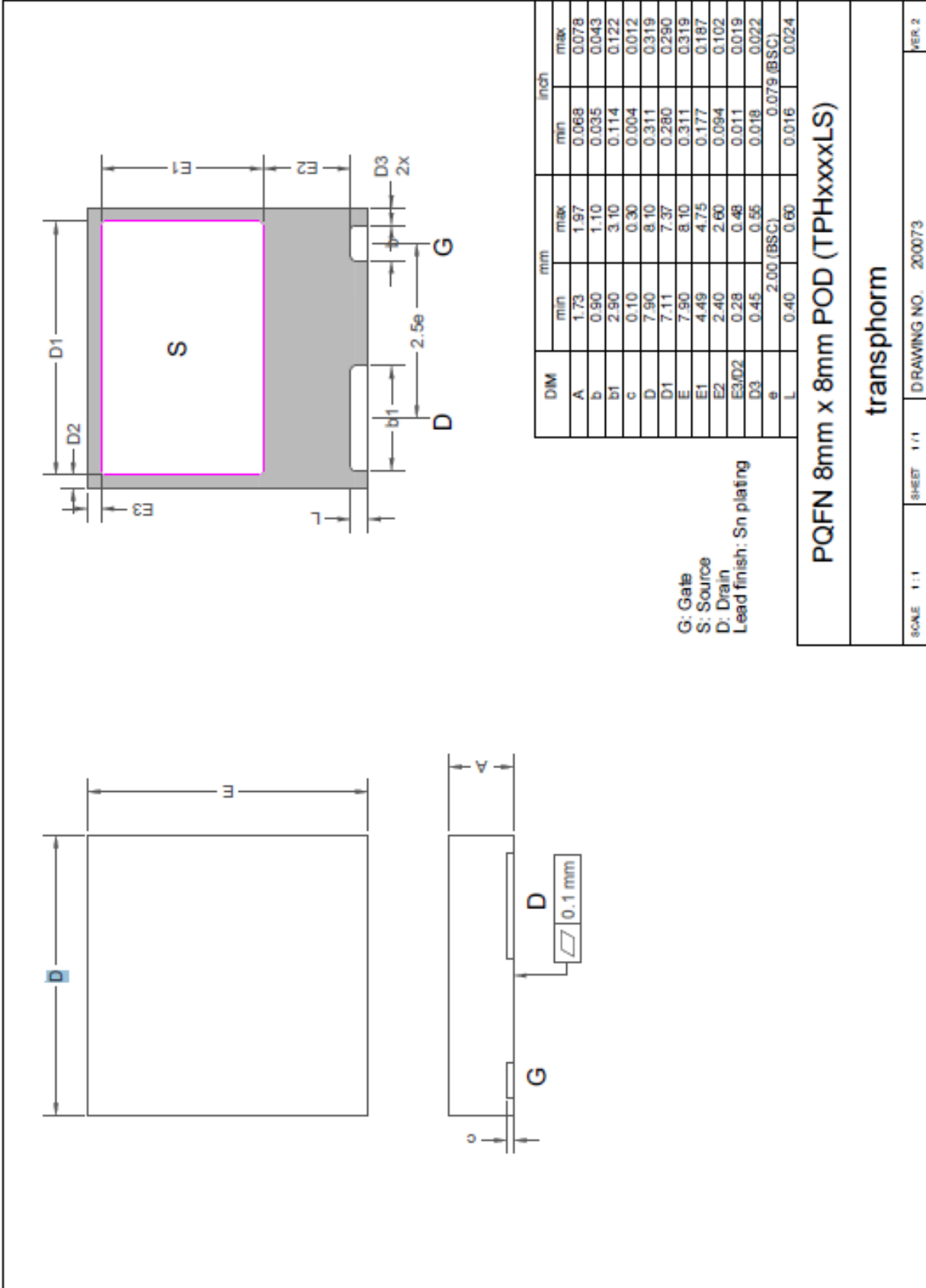

TPH3208L Series

Design Considerations

The fast switching of GaN devices reduces current-voltage cross-over losses and enables high frequency operation while simultaneously achieving high efficiency. However, taking full advantage of the fast switching characteristics of GaN switches requires adherence to specific PCB layout guidelines and probing techniques.

Before evaluating Transphorm GaN devices, see application note [Printed Circuit Board Layout and Probing for GaN Power Switches](#). The table below provides some practical rules that should be followed during the evaluation.

When Evaluating Transphorm GaN Devices:

DO	DO NOT
Minimize circuit inductance by keeping traces short, both in the drive and power loop	Twist the pins of TO-220 or TO-247 to accommodate GDS board layout
Minimize lead length of TO-220 and TO-247 package when mounting to the PCB	Use long traces in drive circuit, long lead length of the devices
Use shortest sense loop for probing; attach the probe and its ground connection directly to the test points	Use differential mode probe or probe ground clip with long wire
See AN0003 : Printed Circuit Board Layout and Probing	

Application Notes

- [AN0002](#): Characteristics of Transphorm GaN Power Switches
- [AN0003](#): Printed Circuit Board Layout and Probing
- [AN0004](#): Designing Hard-switched Bridges with GaN
- [AN0008](#): Drain Voltage and Avalanche Ratings for GaN FETs
- [AN0009](#): Recommended External Circuitry for GaN FETs

Evaluation Boards

- TDHBG2500P100-KIT: 2.5KW hard-switched half-bridge, buck or boost evaluation platform

TPH3208L Series

Revision History

Version	Date	Change(s)
0	11/14/2016	Release L series datasheet