

THIS DRAWING IS UNPUBLISHED. RELEASED FOR PUBLICATION
 © COPYRIGHT - By - ALL RIGHTS RESERVED.

LOC	DIST	REVISIONS			
P	LTR	DESCRIPTION	DATE	DWN	APVD
GP	00	A	INITIAL RELEASE	07JUL2015	MY GG

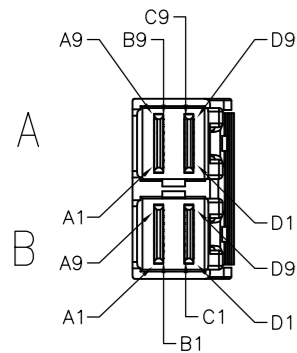

P1

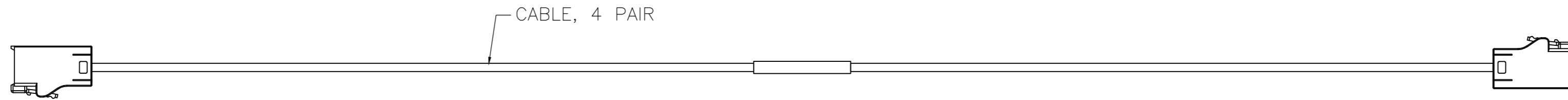
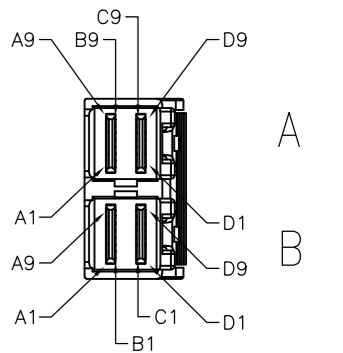
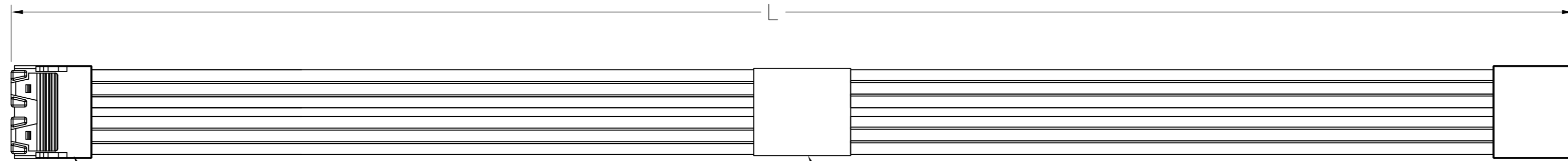

P2

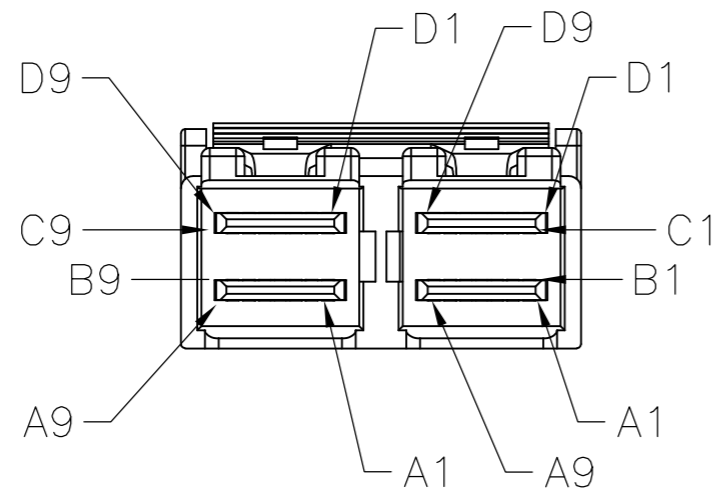

CONNECTOR FACE
-LATCH UP

1. ASSEMBLY TO BE 100% TESTED FOR CONTINUITY, SHORTS, AND OPENS, CABLES ASSEMBLYS ARE ALSO TO BE 100% TESTED FOR SIGNAL INTEGRITY, TO SAS 3.0 REQUIREMENTS.

2. ROHS AND REACH COMPLIANCE: PRODUCT AND PROCESSING MEETS REQUIREMENTS OF TE SPECIFICATION TEC-138-702.

3. LABEL CENTERED AND LABEL INFORMATION AS BELOW:

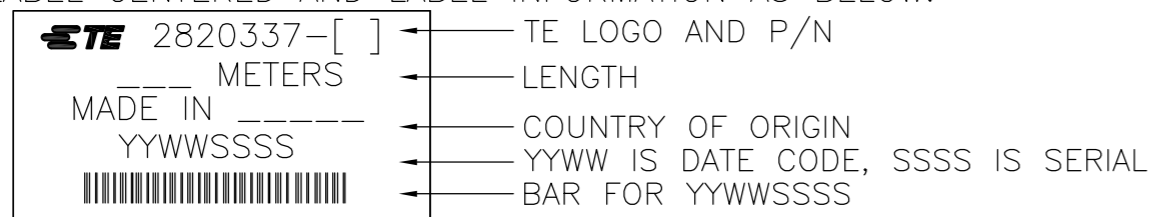

4. SEE SHEET #2 FOR WIRING SCHEMATIC.

500 +25 -0	2820337-2
300 +25 -0	2820337-1
"L"[MM]	TE P/N

THIS DRAWING IS A CONTROLLED DOCUMENT.		DWN M.YI 16/JUN/2014	TE Connectivity	
DIMENSIONS: mm		CHK G.GUTGOLD 16/JUN/2014		
TOLERANCES UNLESS OTHERWISE SPECIFIED:		APVD G.GUTGOLD 16/JUN/2014	NAME C/A, INTERNAL HD MINI SAS, STR TO STR 100 OHMS, 8X, HALOGENATED	
0 PLC ± - 1 PLC ± - 2 PLC ± - 3 PLC ± - 4 PLC ± - ANGLES ± -		PRODUCT SPEC -	SIZE A2	
MATERIAL -		APPLICATION SPEC -	CAGE CODE 00779	DRAWING NO C=2820337
FINISH -		WEIGHT -	SCALE N.T.S.	SHEET 1 OF 2
CUSTOMER DRAWING			RESTRICTED TO -	REV A

THIS DRAWING IS UNPUBLISHED. RELEASED FOR PUBLICATION
 © COPYRIGHT - By - ALL RIGHTS RESERVED.

LOC	DIST	REVISIONS					
GP	00	P	LTR	DESCRIPTION	DATE	DWN	APVD
		-		SEE SHEET 1	-	-	-

P1-A

P2-A

P1-B

P2-B

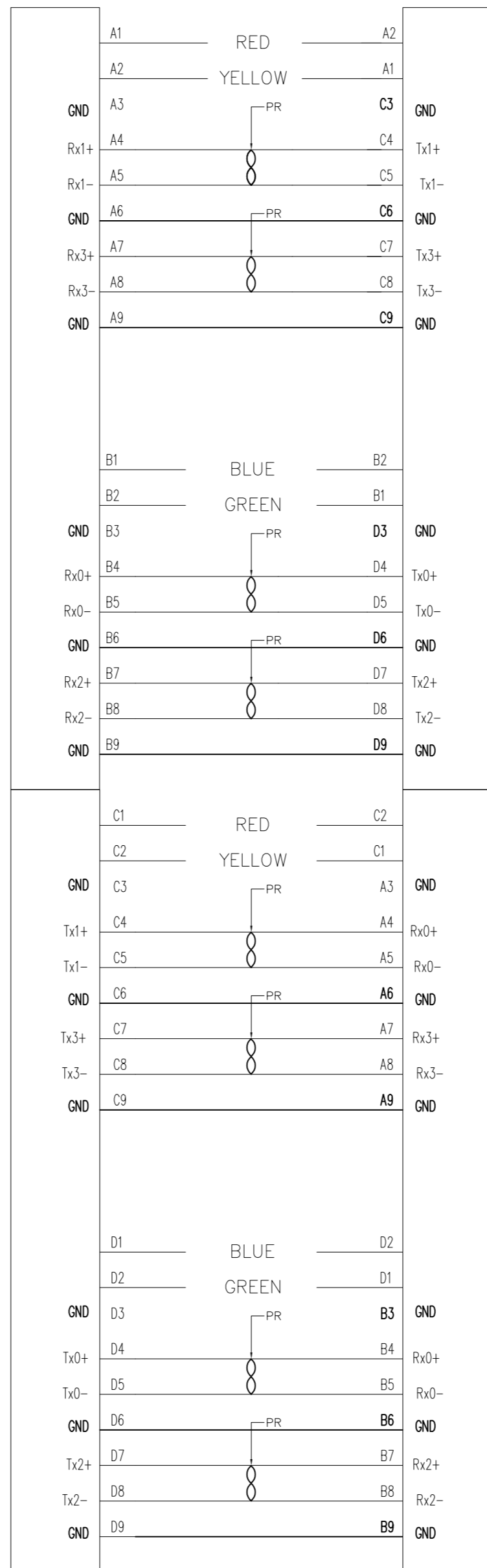
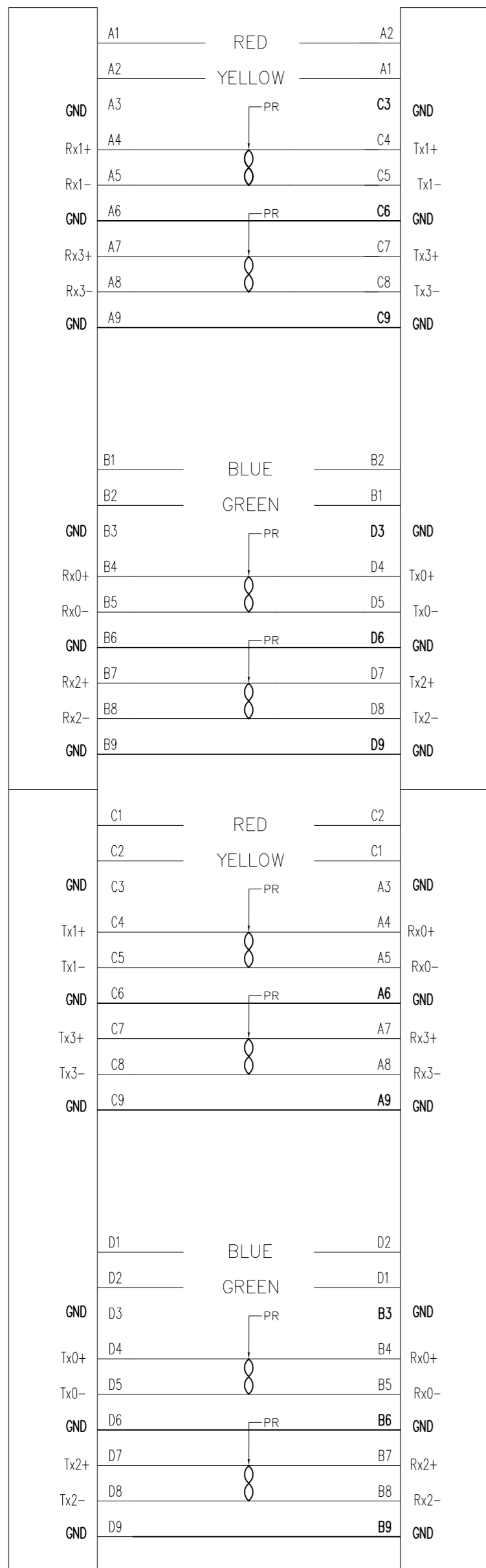

WIRING PATTERN

THIS DRAWING IS A CONTROLLED DOCUMENT.		DWN	16/JUN/2014	STE TE Connectivity
DIMENSIONS: mm		CHK	16/JUN/2014	
TOLERANCES UNLESS OTHERWISE SPECIFIED:		APVD	16/JUN/2014	
0 PLC ± - 1 PLC ± - 2 PLC ± - 3 PLC ± - 4 PLC ± - ANGLES ± -		PRODUCT SPEC		
MATERIAL		G.GUTGOLD		NAME
FINISH		G.GUTGOLD		C/A, INTERNAL HD MINI SAS, STR TO STR 100 OHMS, 8X, HALOGENATED
		WEIGHT	-	SIZE
		CUSTOMER DRAWING	A2	CAGE CODE
		SCALE	N.T.S.	DRAWING NO
		SHEET	2 of 2	RESTRICTED TO
		REV	A	

2820337