

REVISIONS				
P.	LTN.	DESCRIPTION	DATE	APVD.
C		REVISED PER ECO-14-013273	31OCT2014	AP DD

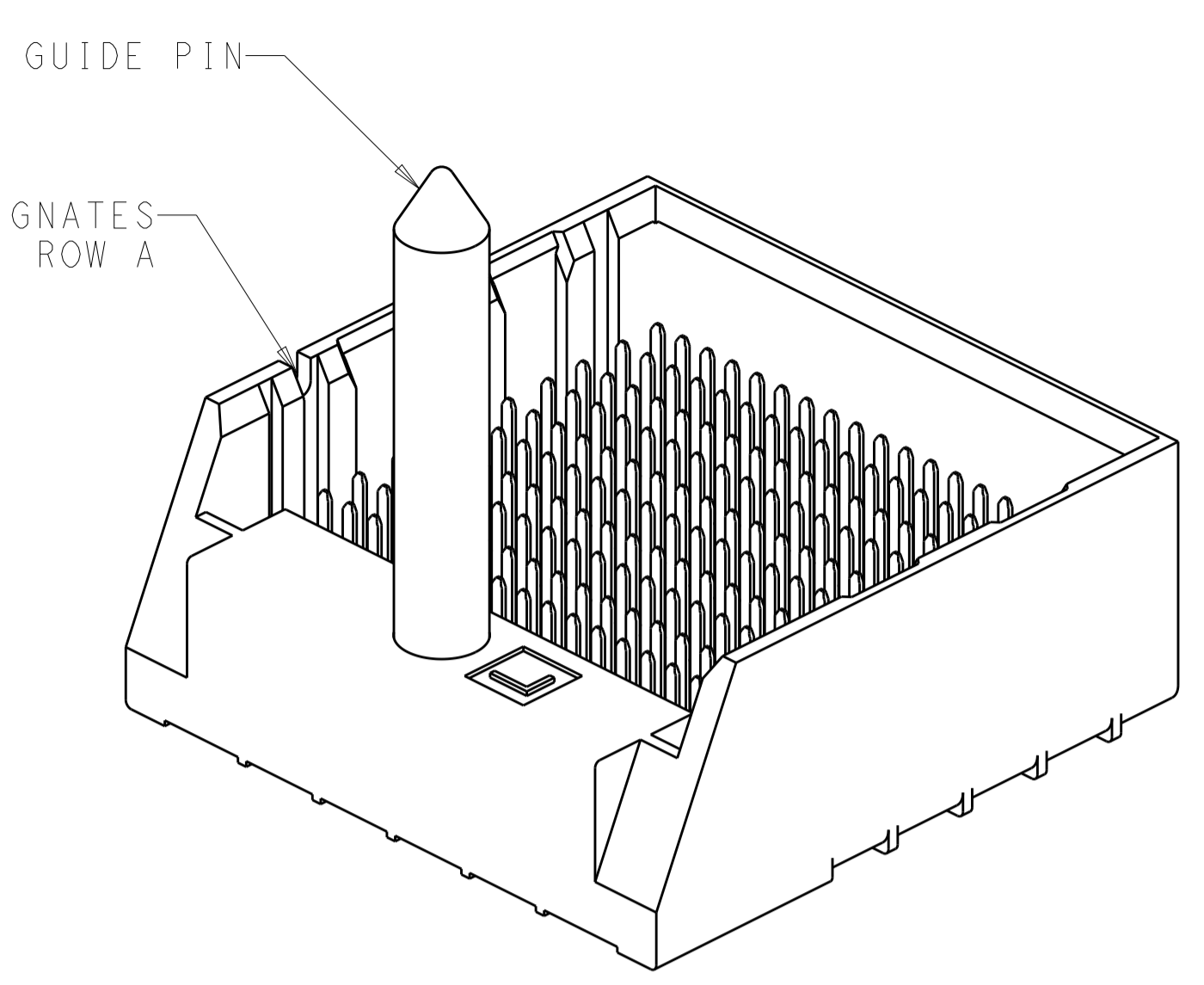

- 1 MATERIAL:
HOUSING: LCP GLASS FILLED UL94V-0
TERMINALS: HIGH PERFORMANCE COPPER ALLOY
- 2 FINISH:
30μ" MIN GOLD IN CONTACT AREA
SELECTIVE TIN ON PCB TAILS.
NICKEL OVERALL.
- 3. SCREWS PACKAGED IN END OF PACKAGING TUBE

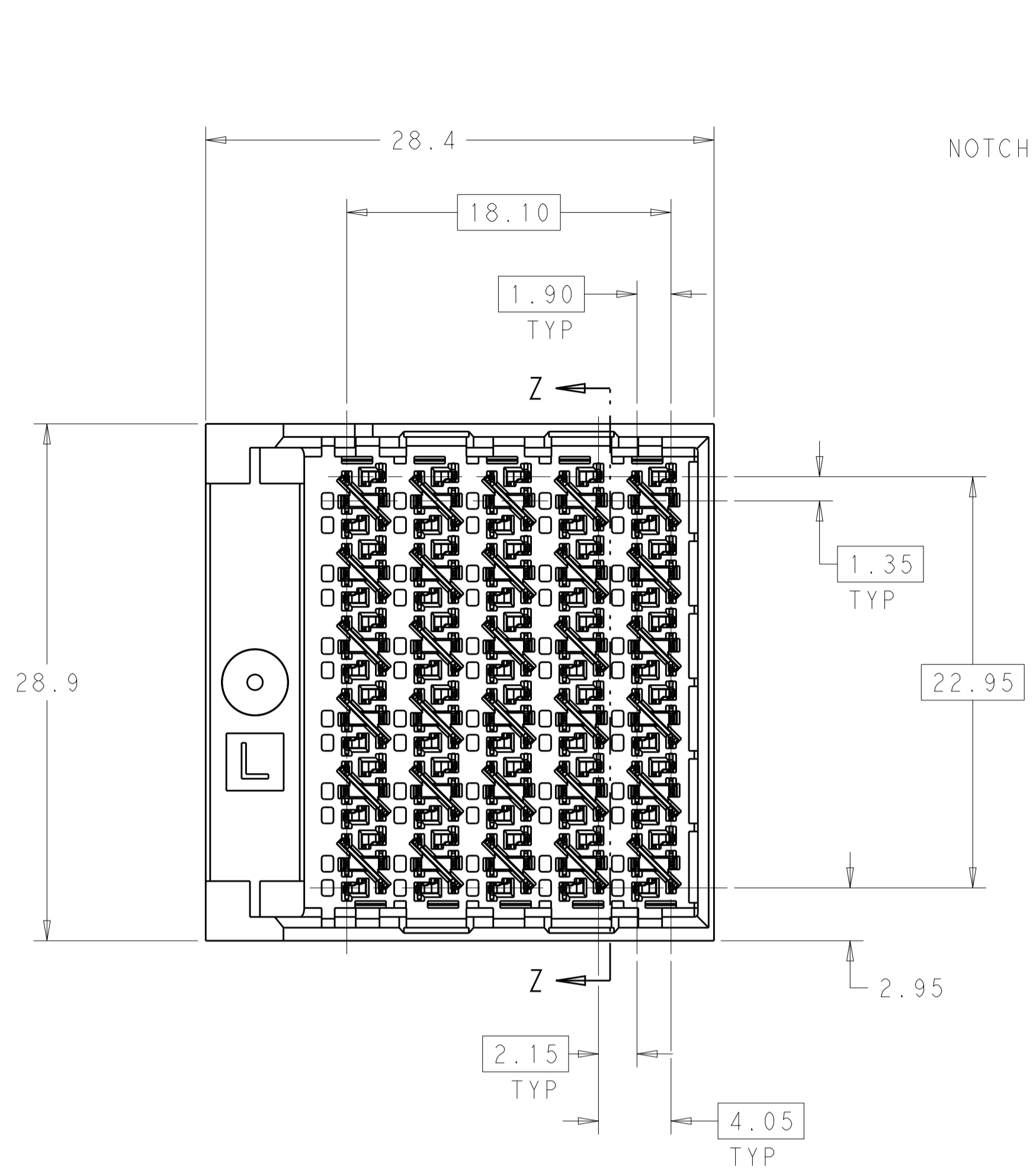
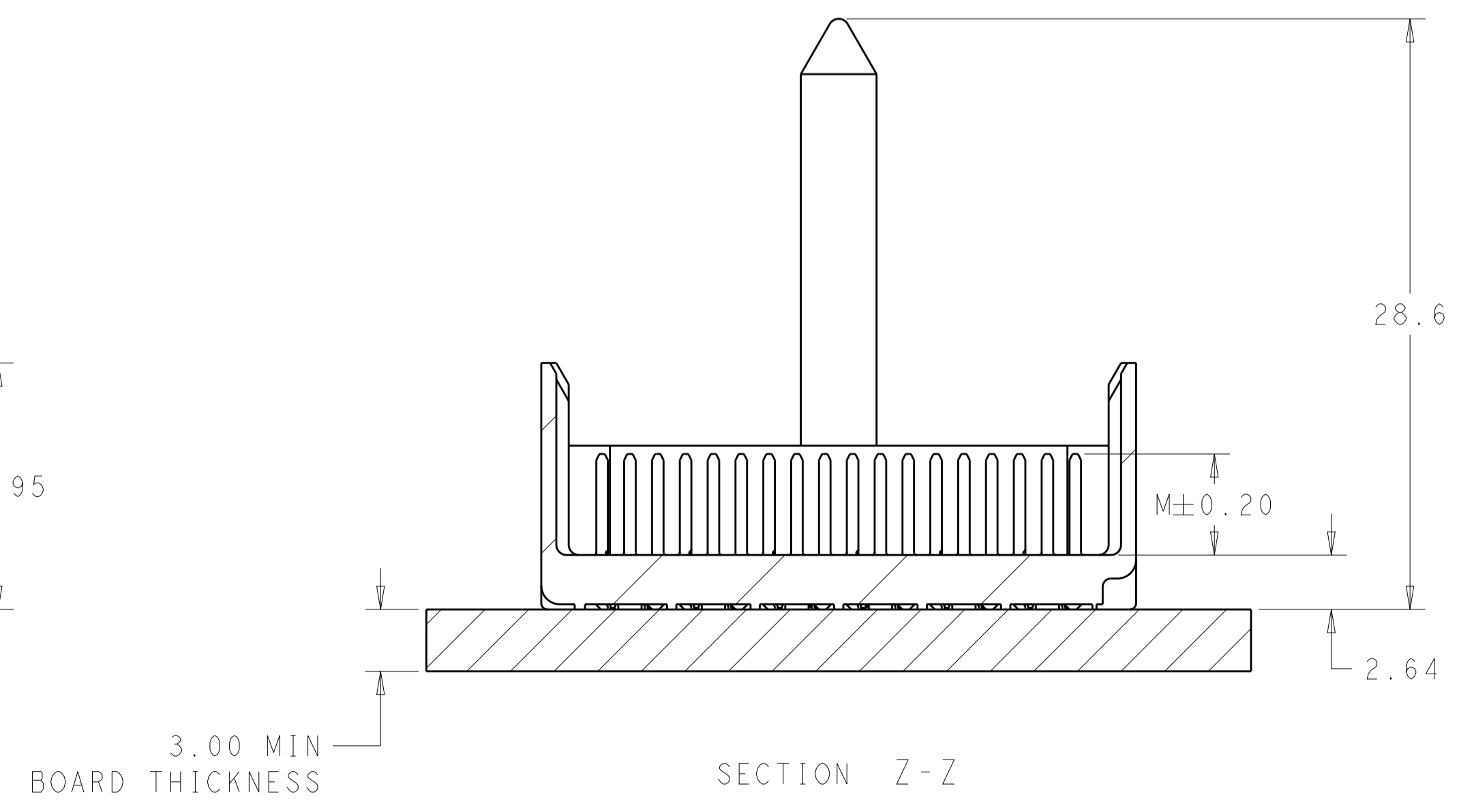
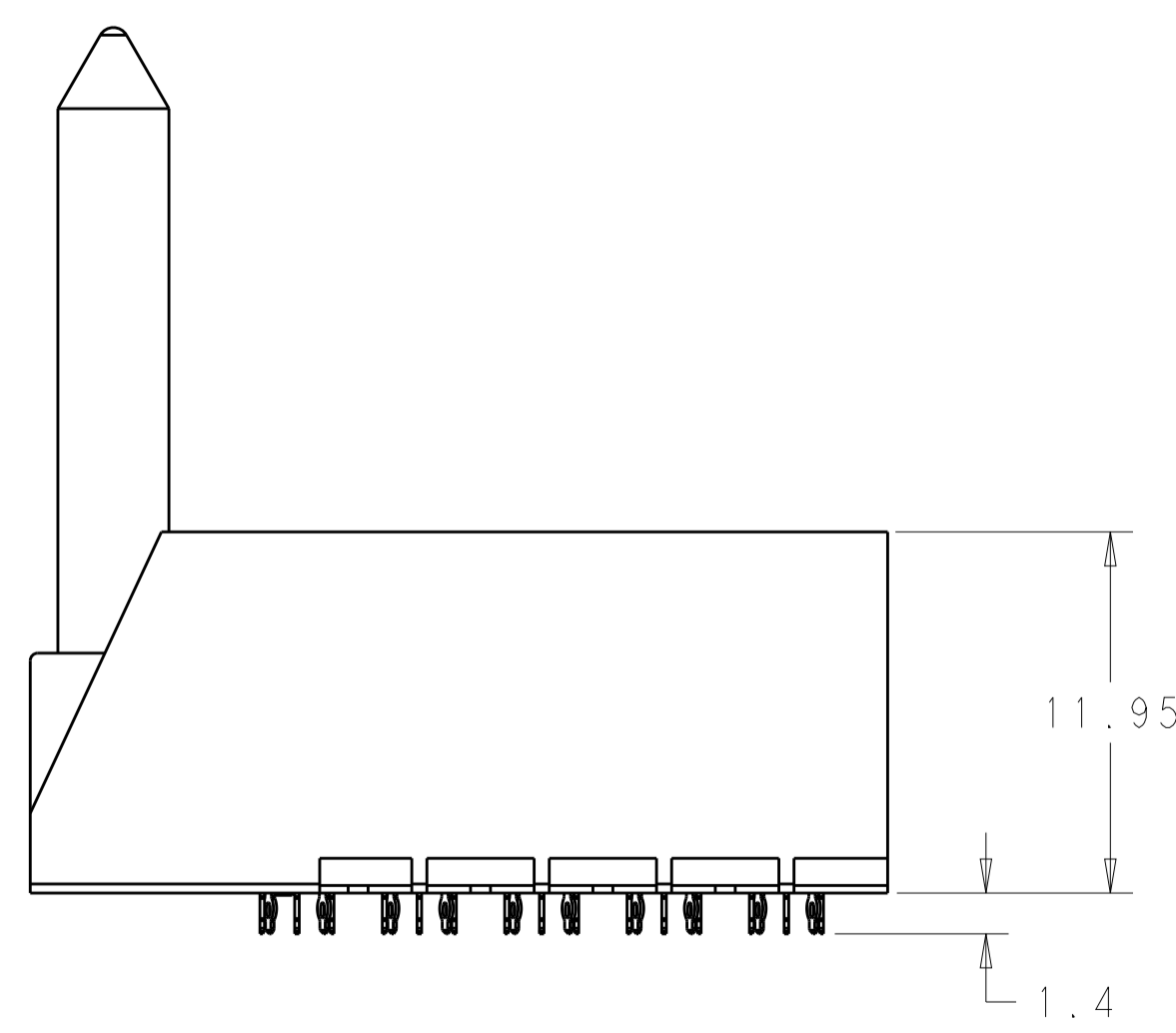
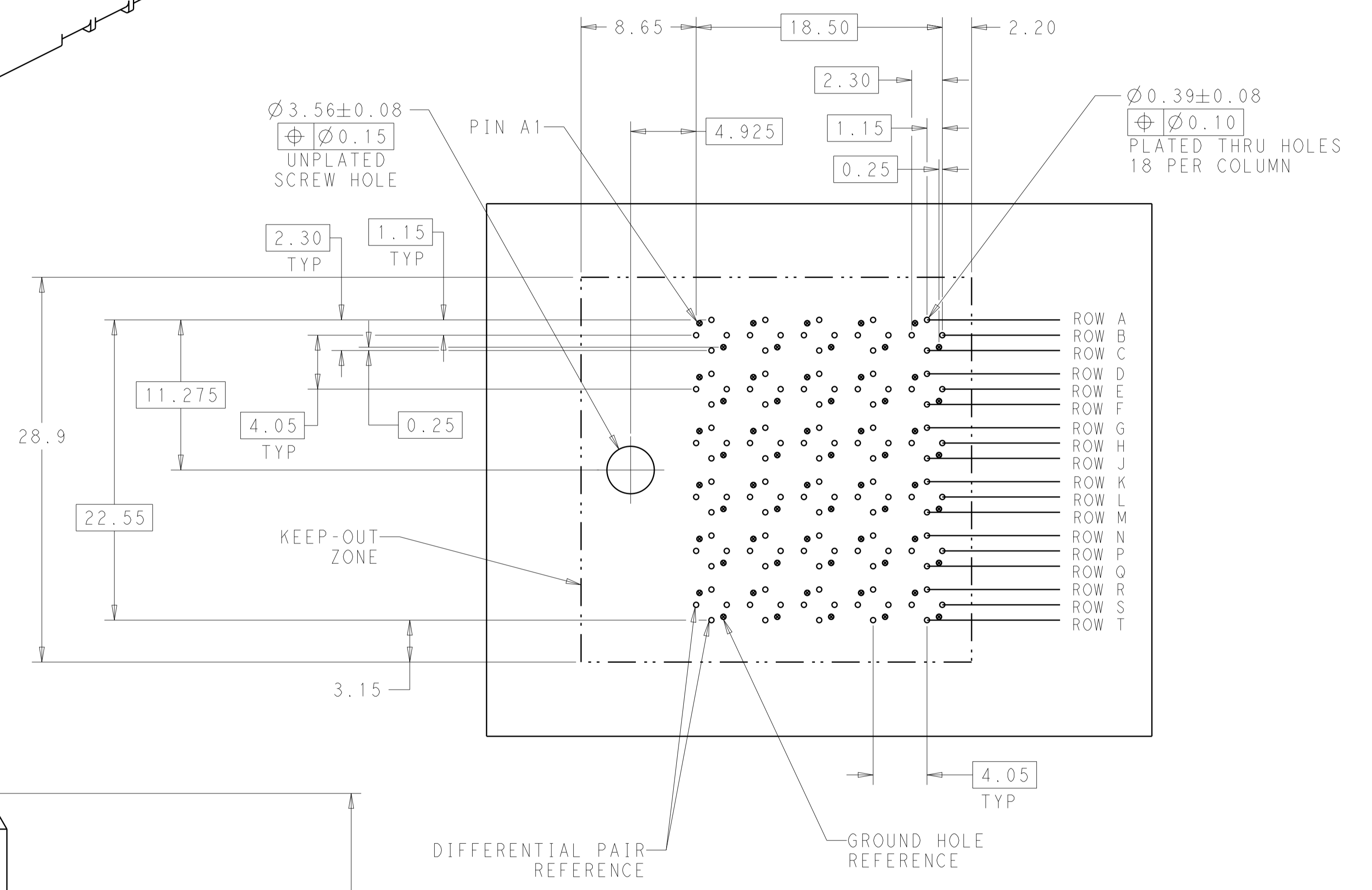

LEFT GUIDED
BACKPLANE HOLE PATTERN
(CONNECTOR SIDE)
SCALE 4:1

2	5.5	2143250-2
2	4.9	2143250-1
FINISH	DIM M	PART NUMBER

THIS DRAWING IS A CONTROLLED DOCUMENT.		DWN J. K. SHOBER 30DEC2010	TE Connectivity
DIMENSIONS: mm		CHK J. EARY 30DEC2010	
TOLERANCES UNLESS OTHERWISE SPECIFIED:		APVD J. EARY 30DEC2010	NAME IMPACT, 6 PAIR, 10 COLUMN, LEFT GUIDED RIGHT END WALL ASSEMBLY, ORTHOGONAL, 0.39 PTH
0 PLC ± 1 PLC ±0.25 2 PLC ±0.13 3 PLC ± 4 PLC ± ANGLES ±0		PRODUCT SPEC	
MATERIAL		APPLICATION SPEC	SIZE CAGE CODE DRAWING NO RESTRICTED TO A100779C=2143250
FINISH SEE TABLE		WEIGHT	
Customer Drawing		SCALE 4:1	SHEET 1 OF 1 REV C