

THIS DRAWING IS UNPUBLISHED. RELEASED FOR PUBLICATION
 © COPYRIGHT - By - ALL RIGHTS RESERVED.

LOC	DIST	REVISIONS			
P	LTR	DESCRIPTION	DATE	DWN	APVD
AF	50	A	REVISE PER ECR-14-018670	19DEC2014	GRZ JL

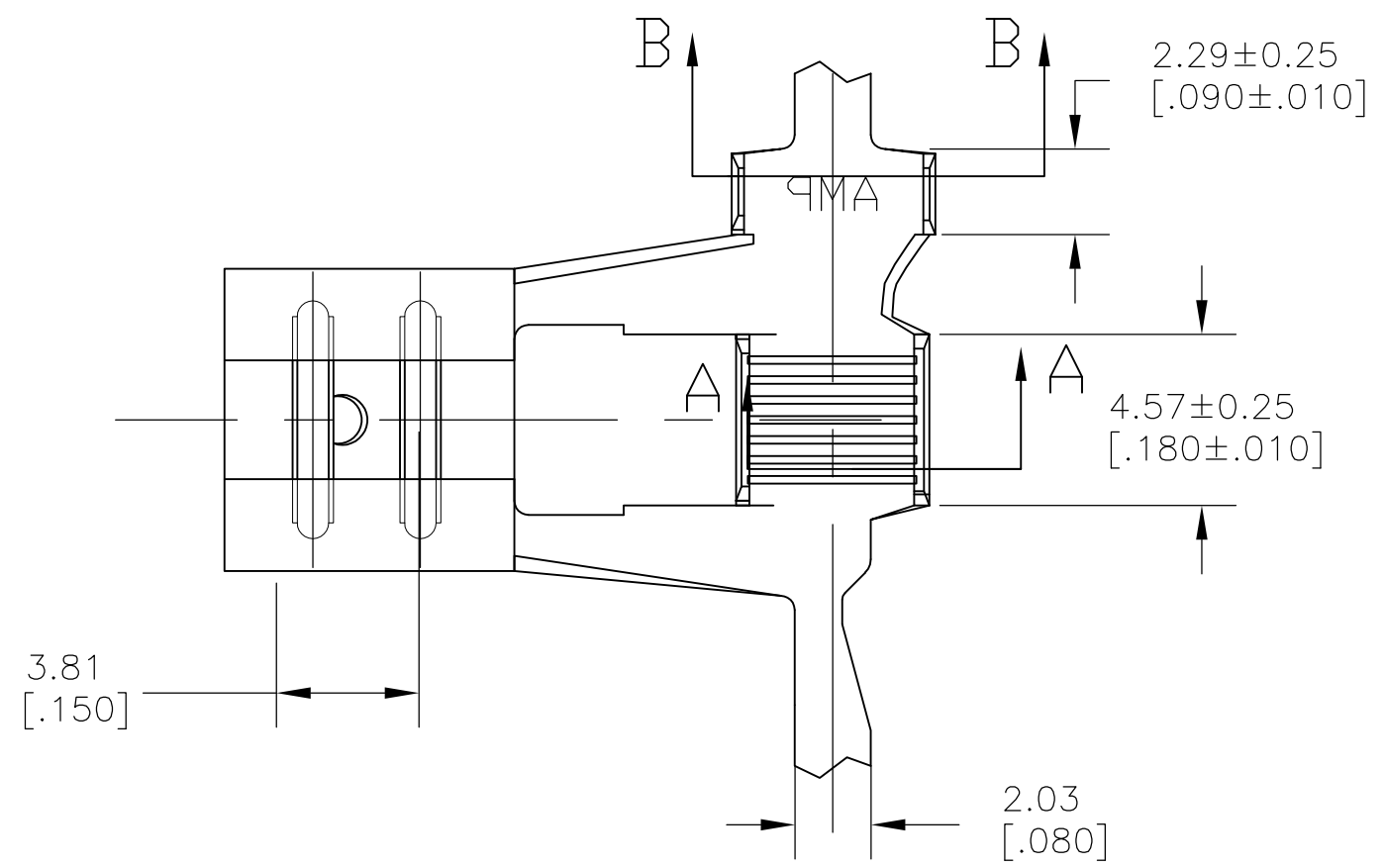

- 1 CONTINUOUS STRIP ON REELS
- 2 WIRE SIZE IS 4000-8500 CMA
CRIMP WIDTH IS 3.94 [.155] F TYPE
CRIMP HEIGHT(±0.05)=(Total CMA+12,300)/250,000
- 3 INSULATION RANGE 2.79-3.81 [.110-.150] DIA
CRIMP WIDTH IS 3.94 [.155], OVERLAP TYPE
- △ 4 0.001016 [.000040] MIN TIN PLATE
- 5 MATING TAB THK IS 0.81±0.025 [.032±.001].

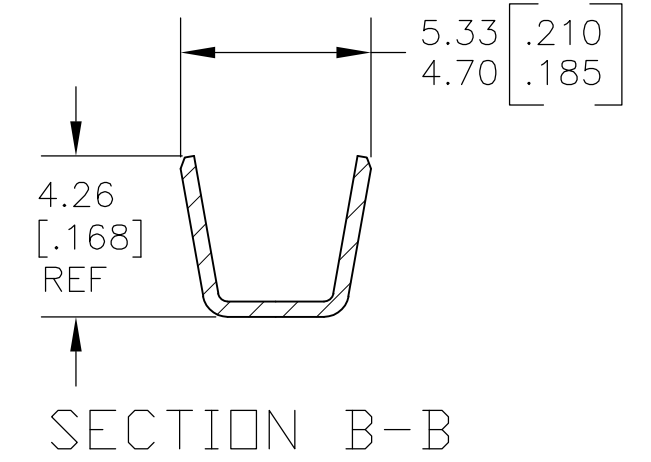
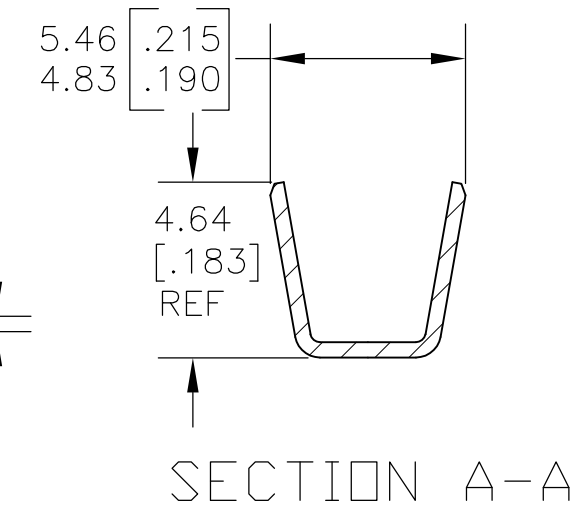
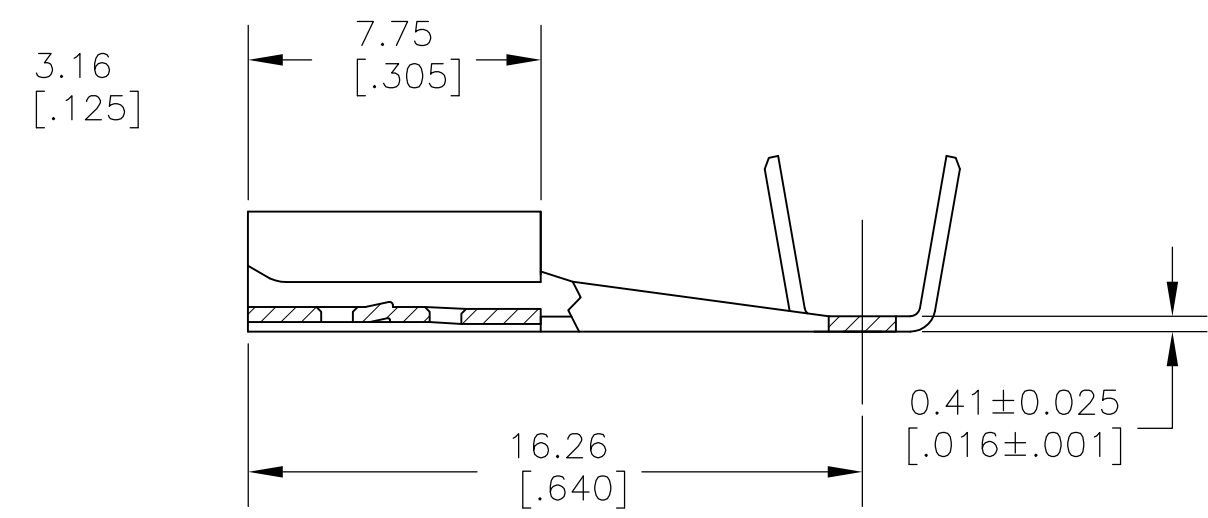
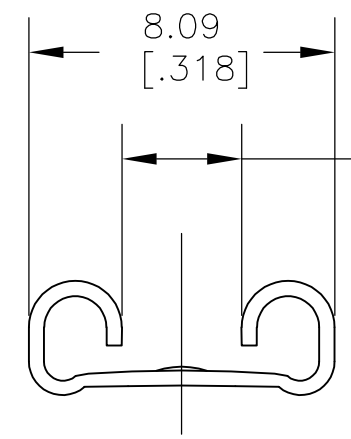

1742979-1
PART NO

THIS DRAWING IS A CONTROLLED DOCUMENT.		DWN jr_ruth 13JUL12	TE Connectivity				
DIMENSIONS: MM [INCHES]		CHK KURT RANDOLPH 13JUL12				NAME	
TOLERANCES UNLESS OTHERWISE SPECIFIED:		APVD KURT RANDOLPH 13JUL12	RECEPTACLE, FASTON, FLAG, AMPLIVAR, 6.35 [.250] SERIES				
0 PLC ± - 1 PLC ± - 2 PLC ± 0.25 [.010] 3 PLC ± - 4 PLC ± - ANGLES ± 5°		PRODUCT SPEC	SIZE	CAGE CODE	DRAWING NO	RESTRICTED TO	
MATERIAL 4M BRASS		APPLICATION SPEC	A3	00779	C-1742979	-	
FINISH △ 4		WEIGHT	CUSTOMER DRAWING		SCALE 5:1	SHEET 1 OF 1	REV A