

4

3

2

1

THIS DRAWING IS UNPUBLISHED. RELEASED FOR PUBLICATION  
 © COPYRIGHT BY TYCO ELECTRONICS CORPORATION. ALL RIGHTS RESERVED.

| LOC | DIST | REVISIONS |     |                           |         |     |      |
|-----|------|-----------|-----|---------------------------|---------|-----|------|
| G   | 86   | P         | LTR | DESCRIPTION               | DATE    | DWN | APVD |
|     |      |           | A1  | REDRAWN PER ECR 10-004009 | 24FEB10 | JR  | TM   |

D

D

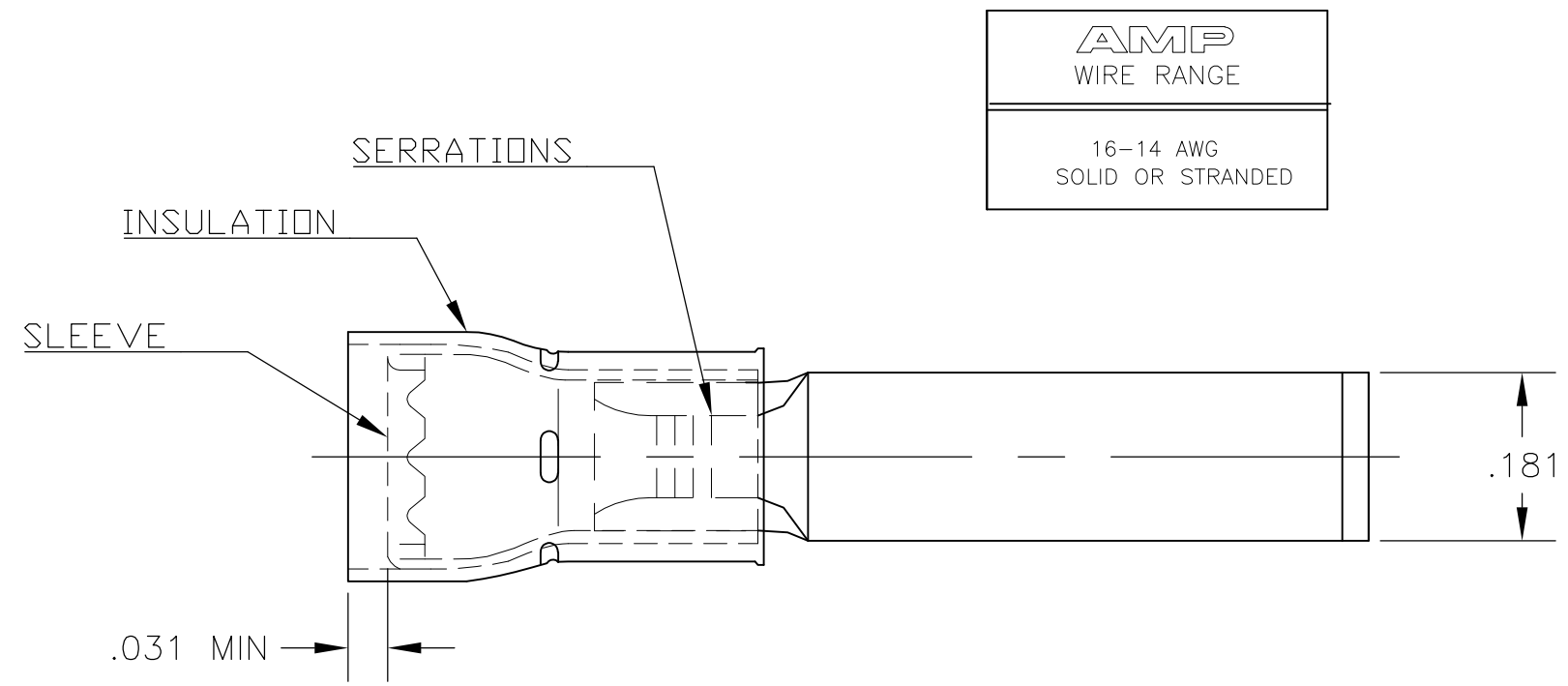

**AMP**  
WIRE RANGE  
16-14 AWG  
SOLID OR STRANDED

- 1 STAMP AMP 16-14, LOCATE APPROX AS SHOWN.
- 2 BODY - COPPER PER ASTM B-152  
SLEEVE - COPPER PER ASTM B-152  
INSULATION - NYLON
- 3 BODY - TIN PLATE PER ASTM B-545  
SLEEVE - TIN PLATE PER ASTM B-545  
INSULATION - COLOR, BLUE
- 4 DIMENSION APPLIES FROM EDGE OF METAL WIRE BBL TO FLANGE.
- 5 WIRE INSULATION DIA .115 TO .170

C

C

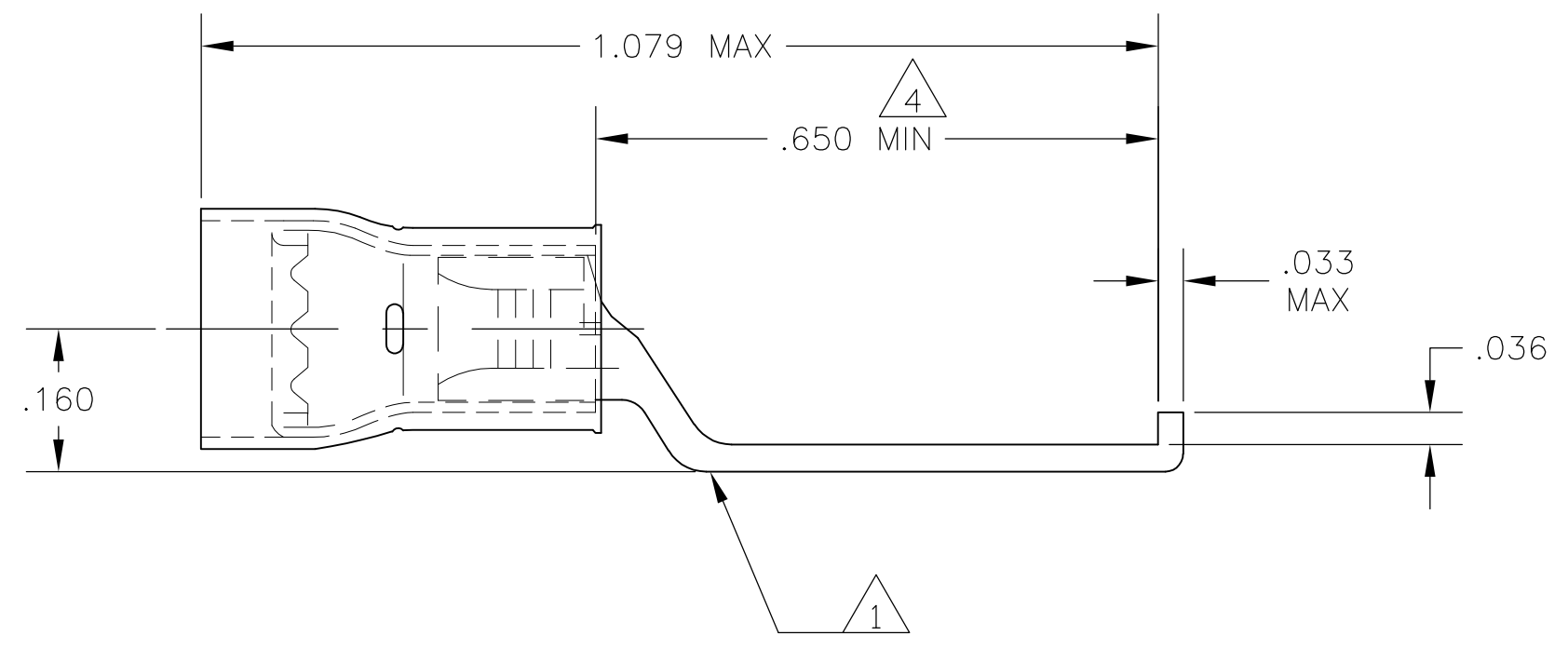

B

B

151794  
PART NO

A

A

|  |  |   |  |   |                                    |  |                    |                        |                    |
|--|--|---|--|---|------------------------------------|--|--------------------|------------------------|--------------------|
| <b>CUSTOMER SERVICE SYSTEMS</b>  |  | MAX RECOMMENDED OPERATING TEMPERATURE:<br>105°C   | THIS DRAWING IS A CONTROLLED DOCUMENT. |   | DWN<br>jr_ruth<br>24FEB10          | <b>Tyco Electronics</b><br>Tyco Electronics Corporation<br>Harrisburg, PA 17105-3608 |                    |                        |                    |
| FOR ADDITIONAL PRODUCT INFORMATION OR COPIES OF DRAWINGS AND TECHNICAL DOCUMENTS | PRODUCT INFORMATION CENTER<br>1-800-522-6752 | VOLTAGE RATING:<br>300V MAX   | DIMENSIONS:<br>INCHES                  | TOLERANCES UNLESS OTHERWISE SPECIFIED:  | CHK<br>TOM MICHIELUTTI<br>24FEB10  | NAME<br>TERMINAL, LIPPED BLADE, PIDG,<br>WIRE SIZE 16-14                             |                    |                        |                    |
| FOR APPLICATION TOOLING INFORMATION  | TOOLING ASSISTANCE CENTER<br>1-800-722-1111  | CIRCULAR MIL AREA:<br>1.04-2.62mm <sup>2</sup> [2,050-5,180]<br>SOLID OR STRANDED   |  | 0 PLC ± -<br>1 PLC ± -<br>2 PLC ± .008<br>3 PLC ± -<br>4 PLC ± -<br>ANGLES ± 5° | APVD<br>TOM MICHIELUTTI<br>24FEB10 | PRODUCT SPEC<br>-  |                    |                        |                    |
| FOR ORDER ENTRY  | 1-800-526-5142                               | THIS DRAWING IS A CONTROLLED DOCUMENT FOR AMP INCORPORATED. IT IS SUBJECT TO CHANGE AND THE CONTROLLING ENGINEERING ORGANIZATION SHOULD BE CONTACTED FOR THE LATEST REVISION. | MATERIAL<br>-                          | FINISH<br>-   | APPLICATION SPEC<br>-              | SIZE<br>A3   | CAGE CODE<br>00779 | DRAWING NO<br>G-151794 | RESTRICTED TO<br>- |
|  |  |   |  |   | CUSTOMER DRAWING                   |  | SCALE<br>5:1       | SHEET<br>1 OF 1        | REV<br>A1          |