

THIS INFORMATION IS CONFIDENTIAL AND PROPRIETARY TO CW INDUSTRIES INCORPORATED AND ITS AFFILIATES. IT MAY NOT BE DISCLOSED TO ANYONE OTHER THAN CW INDUSTRIES PERSONNEL, WITHOUT WRITTEN AUTHORIZATION FROM CW INDUSTRIES INCORPORATED, SOUTHAMPTON, PENNSYLVANIA USA.

DIMENSIONS IN INCHES (MILLIMETERS)  
DO NOT SCALE DRAWING .....

Dwg. No.  
**GRS-2011-2020**

**PANEL PIERCING**

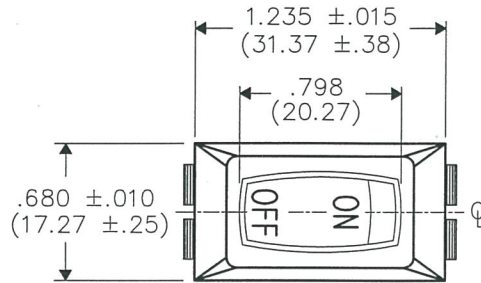
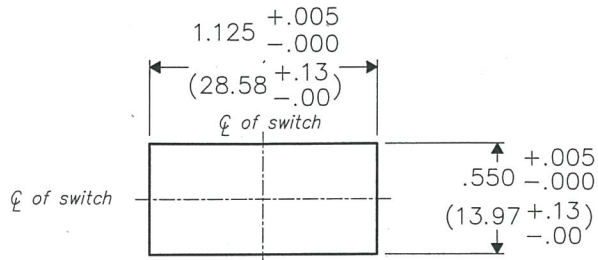

**SWITCH COLOR - Black**  
**LEGEND COLOR - White**

**SWITCH RATINGS:**

**UL & CSA**  
13A. 125VAC 10A. 250VAC  
1/2 H.P. 125-250 VAC  
5A. 14V (T) 6A. 125V L

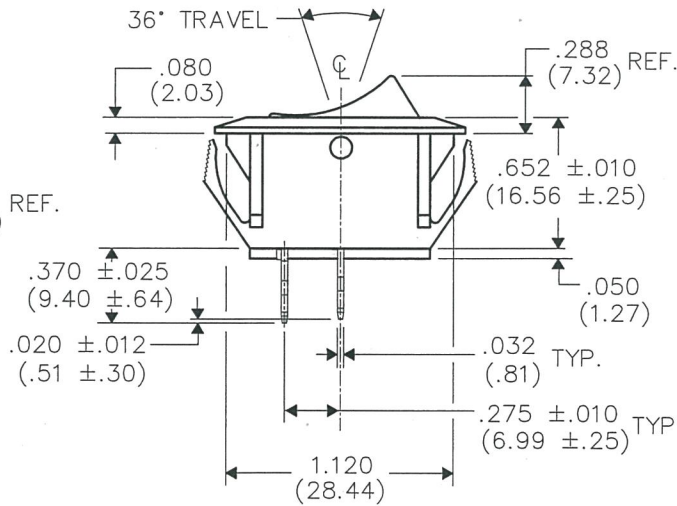
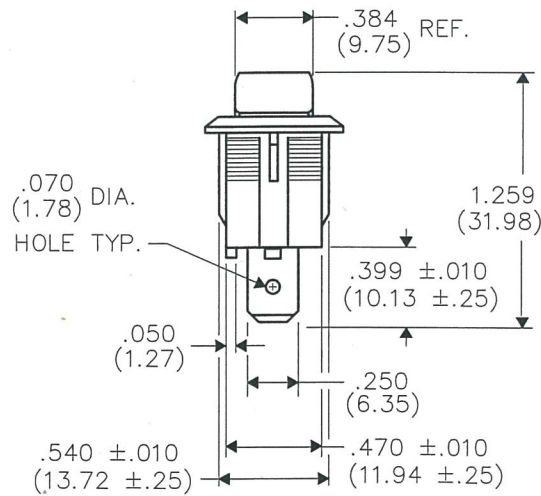

B-FORMAT 2002

**REVISIONS**

|   |   |
|---|---|
| 0 | RELEASED.<br>7-01-13<br>Jul. 19, 2013   |
| 1 | Redrawn. Removed barrier<br>& dimensions.<br>DGW 7-23-2015<br><i>G.G.</i> JUL 23 2015 |

**CW INDUSTRIES**  
Southampton, Pa. 18966

TOLERANCES UNLESS OTHERWISE SPECIFIED

|                            |                           |
|----------------------------|---------------------------|
| 2 Place Decimal $\pm .010$ | METRIC                    |
| 3 Place Decimal $\pm .005$ | 1 Place Dec. $\pm .25$ mm |
| Angles ..... $\pm 1^\circ$ | 2 Place Dec. $\pm .13$ mm |

Made for: CW IND.  
Drawn by: DGW 7-01-13  
Checked by: *G. GULD 7-23-15*  
Approved: *G. GULD 7-23-15*

Title: **ROCKER SWITCH ASSEMBLY S.P.S.T.**  
**NON-POLARIZED W/BARRIER**  
**1.125" x .550" PANEL**

Division: **SWITCH**

Dwg. No. **GRS-2011-2020**

**MASTER**