

BOTTOM

BOTTOM

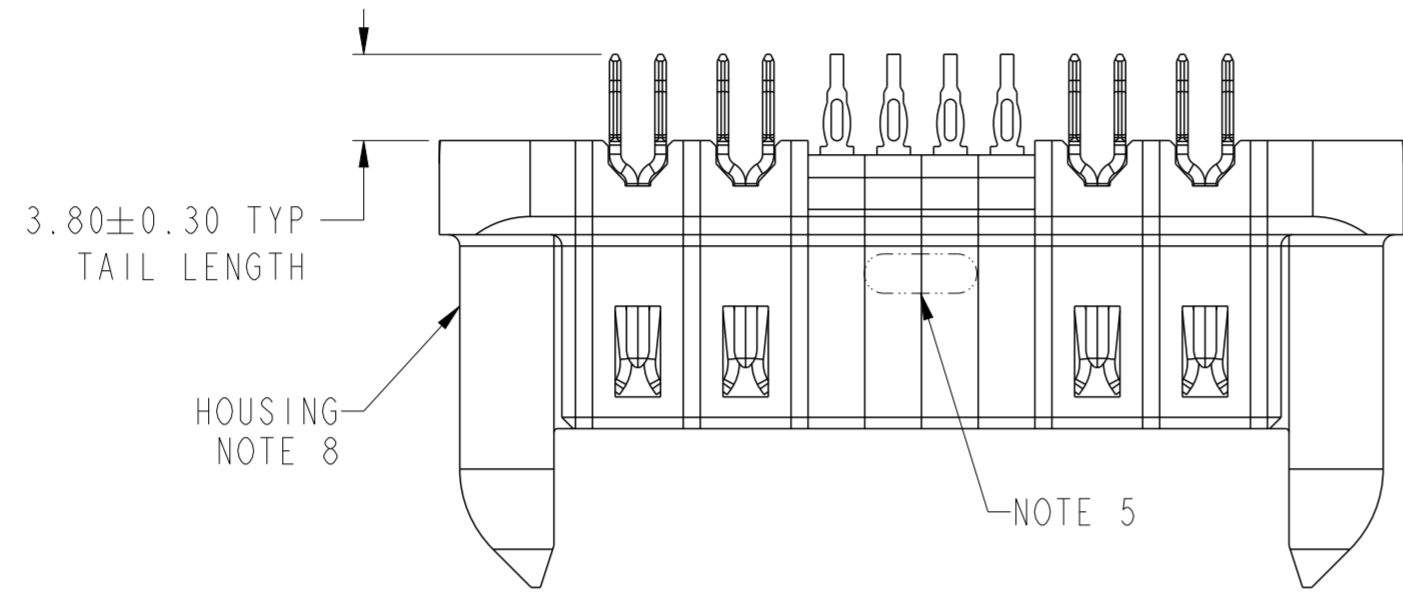

2x Ø2.29

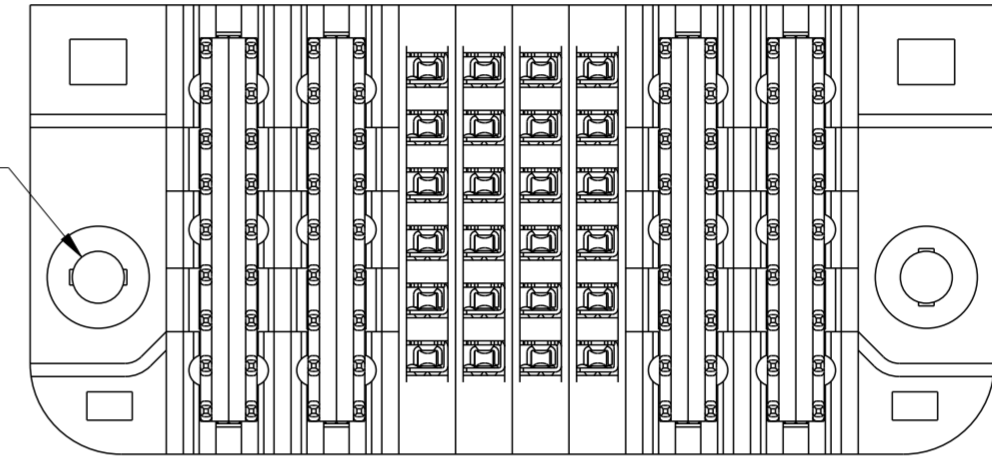

BOTTOM VIEW

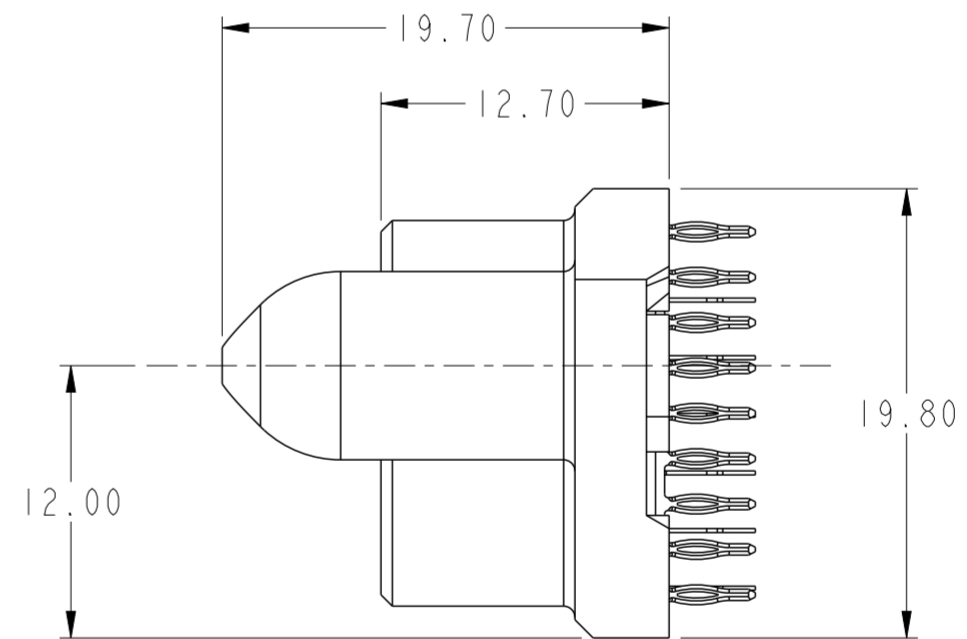
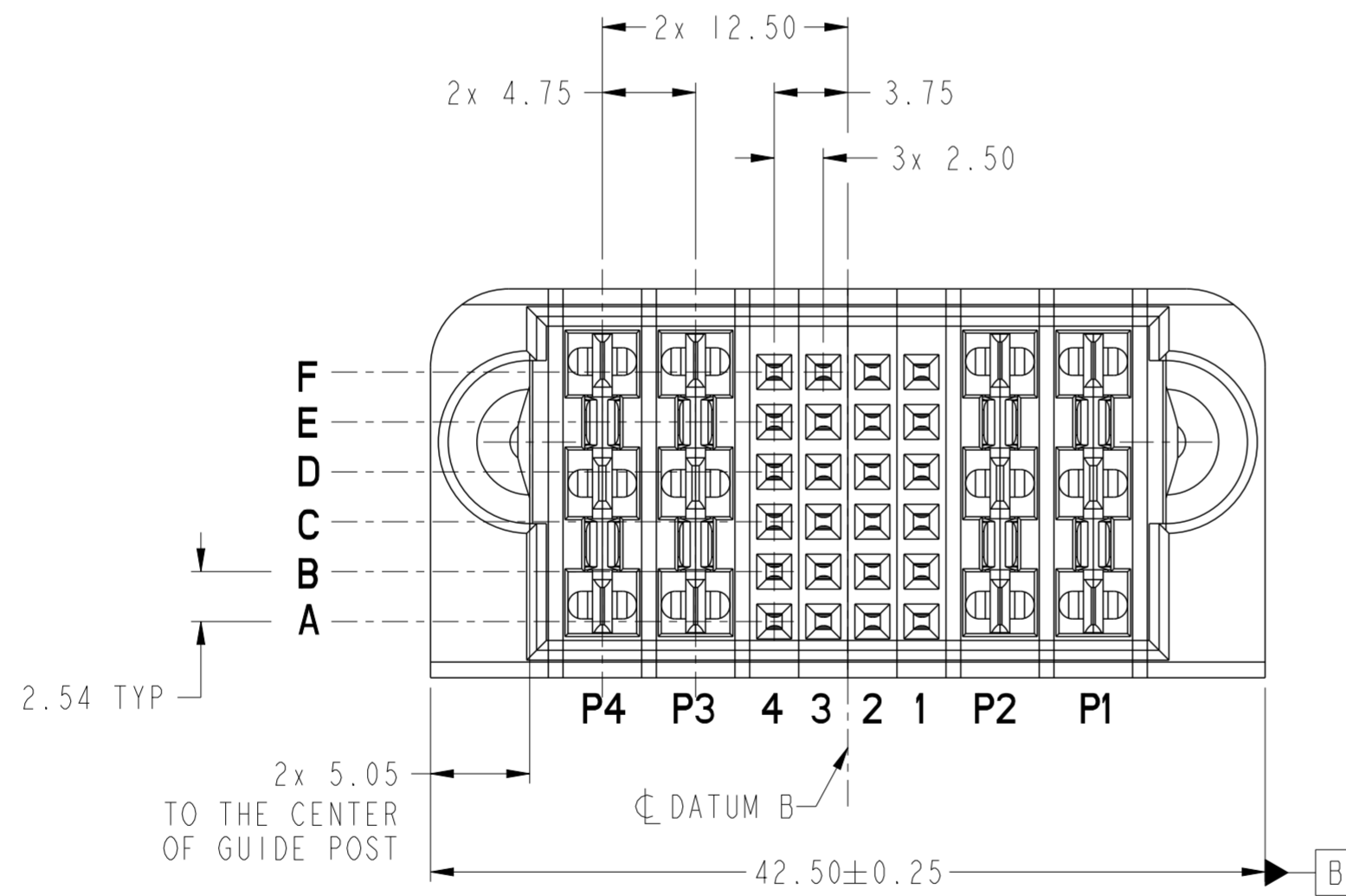

Amphenol
FCi

© 2016 AFci

| | | | | | | | | | | |
|---------------------------------------|---------------------|------|----------------|-------------------------|---|--------|------------------------|----------|--------------|----------|
| spec ref | * | dr | De-Ming Lu | 2015/05/05 | projection | MM | size | A2 | scale | 3:1 |
| tolerance std | ISO 406 ISO 1101 | eng | De-Ming Lu | 2016/07/07 | | | ecn no | - | rel level | Released |
| TOLERANCES UNLESS OTHERWISE SPECIFIED | | chr | Martin Li | 2016/07/07 | | | | | | |
| surface | ISO 1302 | appr | Pei-Ming Zheng | 2016/07/07 | product family | PWRMAX | rel level | Released | rev | A |
| | linear | 0.X | ±0.5 | Amphenol FCi | 2HP + 24S + 2HP VERTICAL PRESS-FIT RECEPTACLE | | dwg no | 10135066 | sheet 1 of 4 | |
| | | 0.XX | ±0.25 | | cat. no. | - | Product - Customer Drw | | | |
| | angular | 0° | ±2° | | | | | | | |

PDS: Rev :A

STATUS:Released

Printed: Jul 07, 2016

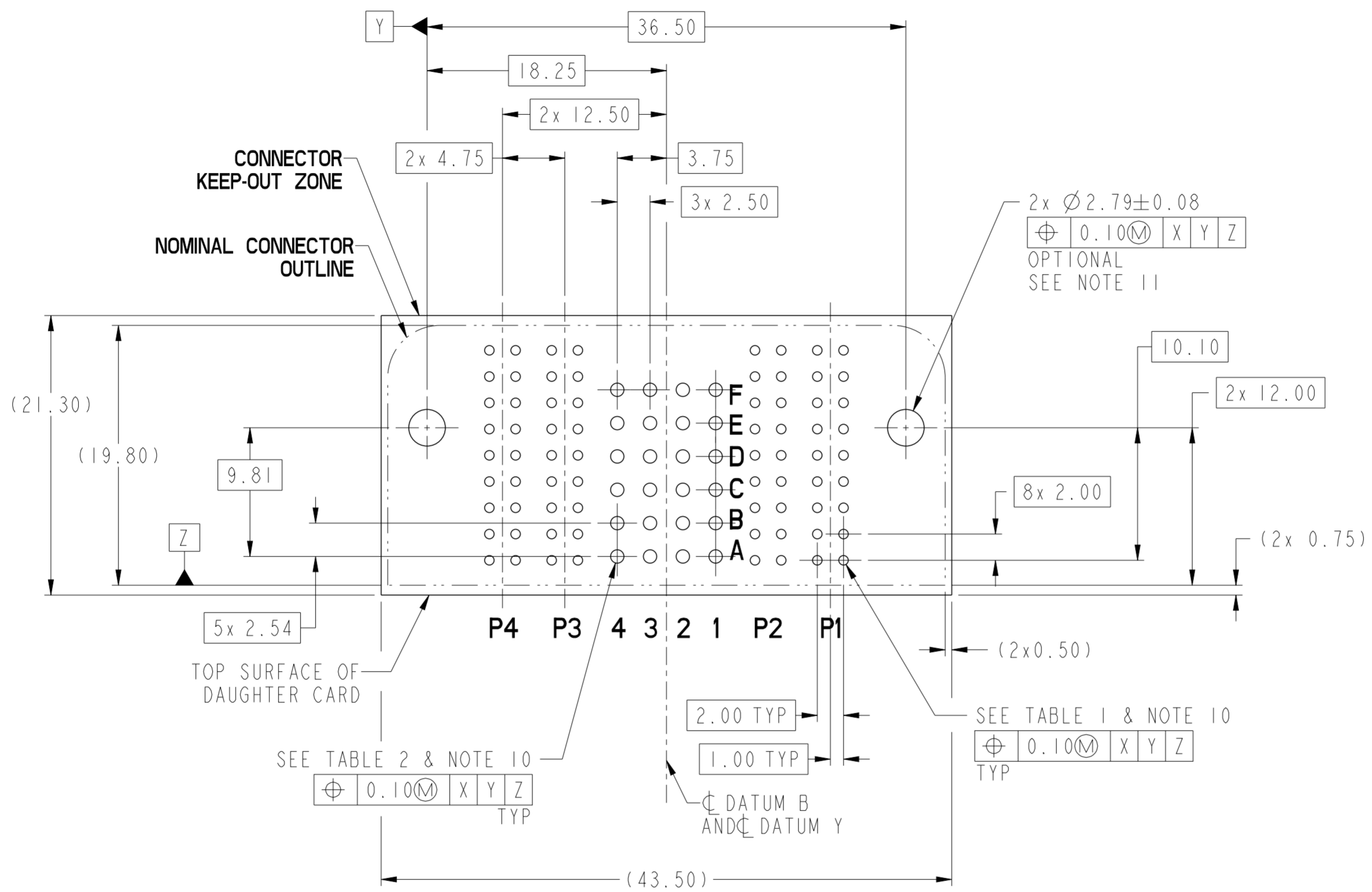

RECOMMENDED PCB LAYOUT
COMPONENT SIDE
NOTE 6

| | | | | | | | | | | | |
|---------------------------------------|--|--------------|----------------|------------------------|--|--------|-----------|----------|-----------|----------|---|
| spec ref | * | dr | De-Ming Lu | 2015/05/05 | projection | MM | size | A2 | scale | 3:1 | |
| tolerance std | ISO 406 ISO 1101 | eng | De-Ming Lu | 2016/07/07 | | | ecn no | - | rel level | Released | |
| TOLERANCES UNLESS OTHERWISE SPECIFIED | | chr | Martin Li | 2016/07/07 | | | | | | | |
| surface | ISO 1302 | appr | Pai-Ming Zheng | 2016/07/07 | product family | PWRMAX | rel level | Released | cat. no. | - | |
| linear | 0.X ±0.5 0.XX ±0.25 0.XXX ±0.100 | Amphenol FCI | | title | 2HP + 24S + 2HP VERTICAL PRESS-FIT RECEPTACLE | | div no | 10135066 | | rev | A |
| angular | 0° ±2° | | | Product - Customer Drw | sheet 2 of 4 | | | | | | |

| TOP LAYER DESCRIPTION | TABLE 1 (PWRMAX POWER) PLATED THROUGH-HOLE REQUIREMENTS | | | | | | | |
|-----------------------|--|------------------|--------------------|------------------|--------------------|---------------|------------------|------------------------|
| | DRILLED HOLE DIAMETER | COPPER THICKNESS | TIN-LEAD THICKNESS | NICKEL THICKNESS | GOLD THICKNESS | TIN THICKNESS | SILVER THICKNESS | FINISHED HOLE DIAMETER |
| TIN-LEAD | 0.81-0.86 (0.85 DRILL) | 0.025 - 0.050 | 0.005 - 0.015 | -- | -- | -- | -- | 0.65 - 0.80 |
| IMMERSION TIN | 0.81-0.86 (0.85 DRILL) | 0.025 - 0.050 | -- | -- | -- | 0.9 - 1.5um | -- | 0.70 - 0.80 |
| IMMERSION SILVER | 0.81-0.86 (0.85 DRILL) | 0.025 - 0.050 | -- | -- | -- | -- | 0.15 - 0.65um | 0.70 - 0.80 |
| COPPER (SEE NOTE 9) | 0.81-0.86 (0.85 DRILL) | 0.025 - 0.050 | -- | -- | -- | -- | -- | 0.70 - 0.80 |
| GOLD | 0.81-0.86 (0.85 DRILL) | 0.025 - 0.050 | -- | 0.003 - 0.007 | FLASH UP TO 0.0002 | -- | -- | 0.69 - 0.80 |

| TOP LAYER DESCRIPTION | TABLE 2 (PWRMAX SIGNALS & LOW POWER) PLATED THROUGH-HOLE REQUIREMENTS | | | | | | | |
|-----------------------|--|------------------|--------------------|------------------|--------------------|---------------|------------------|------------------------|
| | DRILLED HOLE DIAMETER | COPPER THICKNESS | TIN-LEAD THICKNESS | NICKEL THICKNESS | GOLD THICKNESS | TIN THICKNESS | SILVER THICKNESS | FINISHED HOLE DIAMETER |
| TIN-LEAD | 1.125-1.175 | 0.025-0.050 | 0.005-0.015 | -- | -- | -- | -- | 0.94 - 1.10 |
| IMMERSION TIN | 1.125-1.175 | 0.025-0.050 | -- | -- | -- | 0.9 - 1.5um | -- | 0.94 - 1.10 |
| IMMERSION SILVER | 1.125-1.175 | 0.025-0.050 | -- | -- | -- | -- | 0.15 - 0.65um | 0.94 - 1.10 |
| COPPER (SEE NOTE 9) | 1.125-1.175 | 0.025-0.050 | -- | -- | -- | -- | -- | 0.94 - 1.10 |
| GOLD | 1.125-1.175 | 0.025-0.050 | -- | 0.003 - 0.007 | FLASH UP TO 0.0002 | -- | -- | 0.93 - 1.10 |

Amphenol FCI

© 2016 AFCI

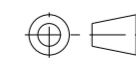
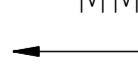
| | | | | | | | | | | | |
|---------------|--|------|----------------|------------|---|---|----------------|-----------------|-----------|----------|------------------------|
| spec ref | * | dr | De-Ming Lu | 2015/05/05 | projection | MM | size | A2 | scale | 3:1 | |
| tolerance std | ISO 406 ISO 1101 | eng | De-Ming Lu | 2016/07/07 |  |  | ecn no | - | rel level | | Released |
| surface | TOLERANCES UNLESS OTHERWISE SPECIFIED linear: 0.X ±0.5 0.XX ±0.25 0.XXX ±0.100 angular: 0° ±2° | chr | Martin Li | 2016/07/07 | | | product family | PWRMAX | rel level | Released | |
| | | appr | Pei-Ming Zheng | 2016/07/07 | | | Amphenol FCI | 2HP + 24S + 2HP | cat. no. | - | Product - Customer Drw |

| | | |
|----------------|-----------------------|--------------|
| PART NUMBER | M2.5 SCREW NOTE 11 | TAIL TYPE |
| 10135066-001LF | OPTIONAL | PRESS-FIT |

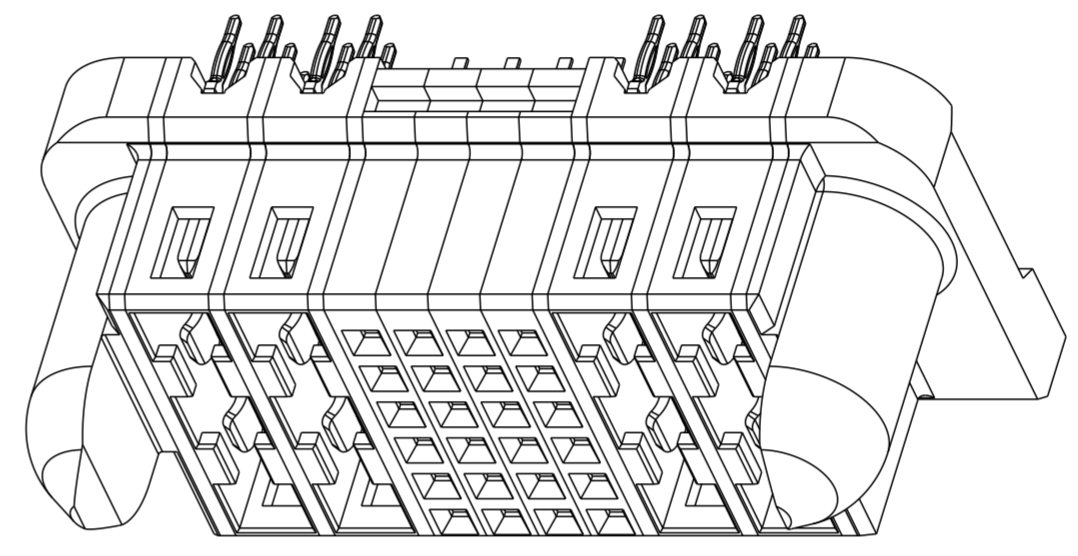

NOTES:

1. CONNECTOR MATERIALS:
HOUSING: HIGH TEMPERATURE THERMOPLASTIC, BLACK
UL 94V-0 COMPLIANT
CONTACTS: HIGH PERFORMANCE COPPER ALLOY
2. CONTACT FINISH (Ref to GS-12-1314 SECTION 5.2)
3. PRODUCT SPECIFICATION: GS-12-1314.
4. APPLICATION SPECIFICATION: GS-20-0447.
5. MANUFACTURER'S NAME, DATE CODE AND OPTIONAL P/N TO APPEAR ON THIS SURFACE. THE P/N CAN BE OMITTED IF THERE IS NOT ENOUGH SPACE ON THIS SURFACE.
6. MINIMUM NOMINAL PCB THICKNESS: 1.6mm
7. PACKAGED IN TUBES.
8. HOUSING COMPONENT WILL WITHSTAND EXPOSURE TO 260°C PEAK TEMPERATURE FOR 10 SECONDS IN A CONVECTION, INFRA-RED, OR VAPOR PHASE REFLOW OVEN.
9. COPPER PLATING THICKNESS IN CENTER OF VIA-HOLE CAN BE NO MORE THAN 0.003 LESS THAN OTHER AREAS.
10. ALL HOLE SIZES ARE FINISHED HOLE SIZES.
11. RECOMMENDED RETENTION TO PCB:
Ø0.110[2.79] THRU HOLE (UNPLATED) FOR M2.5 SELF THREADING SCREW, MAX HEAD Ø0.177[4.50].
RECOMMENDED SCREW LENGTH 0.276[7.00] + PCB THICKNESS.
RECOMMENDED SCREW SEATING TO PCB TORQUE: 2-5 lbf-in (2300-5760 gf-cm).

Amphenol FCI

© 2016 AFCI

| | | | | | | | | | | |
|---------------------------------------|--|--------------|----------------|------------|--|------------------------|-----------|----------|------------------------|--------------|
| spec ref | * | dr | De-Ming Lu | 2015/05/05 | projection | MM | size | A2 | scale | 3:1 |
| tolerance std | ISO 406 ISO 1101 | eng | De-Ming Lu | 2016/07/07 | | | ecn no | - | | |
| TOLERANCES UNLESS OTHERWISE SPECIFIED | | chr | Martin Li | 2016/07/07 | | | rel level | Released | | |
| surface | linear | appr | Pei-Ming Zheng | 2016/07/07 | product family | PWRMAX | rel level | Released | | |
| | angular | Amphenol FCI | | title | 2HP + 24S + 2HP VERTICAL PRESS-FIT RECEPTACLE | | cat. no. | - | Product - Customer Drw | sheet 4 of 4 |
| ISO 1302 | 0.X ±0.5 0.XX ±0.25 0.XXX ±0.100 | | | cat. no. | - | Product - Customer Drw | rel level | Released | Printed: Jul 07, 2016 | |

PDS: Rev :A

STATUS:Released

Printed: Jul 07, 2016