

THIS DRAWING IS UNPUBLISHED. RELEASED FOR PUBLICATION
 © COPYRIGHT BY TYCO ELECTRONICS CORPORATION. ALL RIGHTS RESERVED.

LOC	DIST	REVISIONS					
J	—	P	LTR	DESCRIPTION	DATE	DWN	APVD
			D1	REVISED ECR-16-015552	8NOV'16	DL	TD

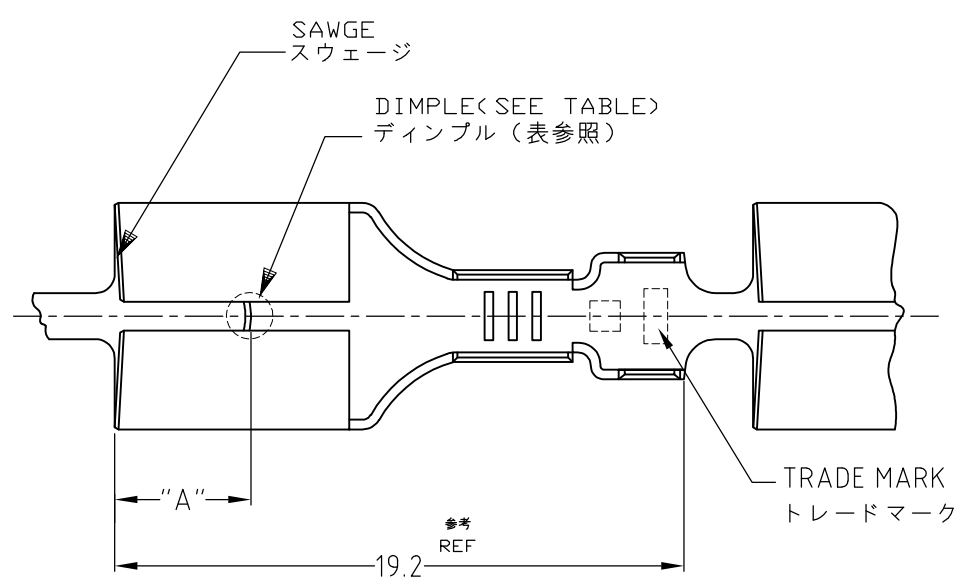

推奨タブ図
RECOMMENDED TAB DIMENSIONS

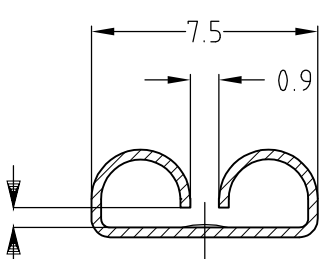
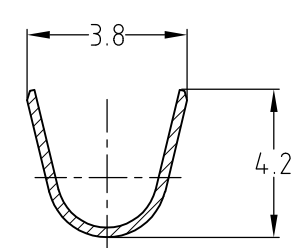
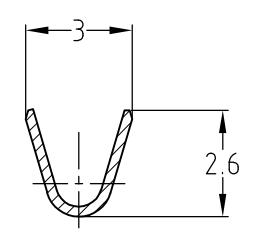
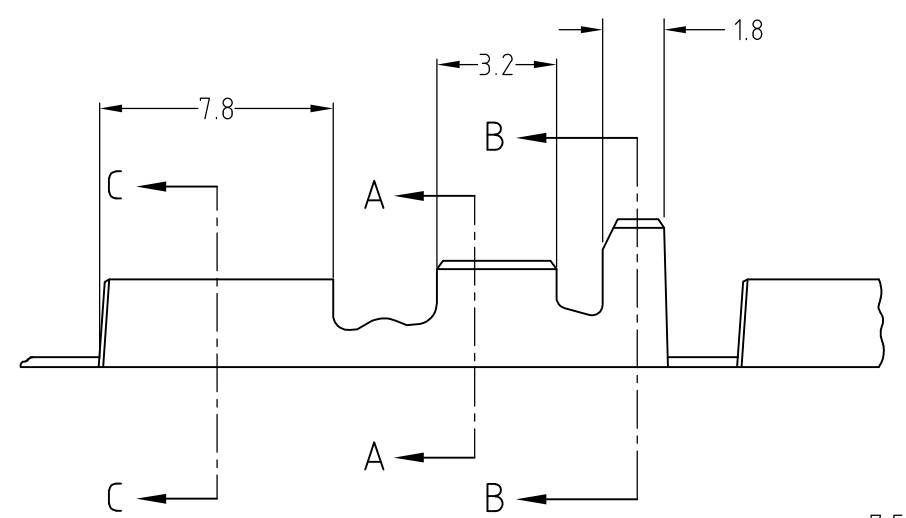
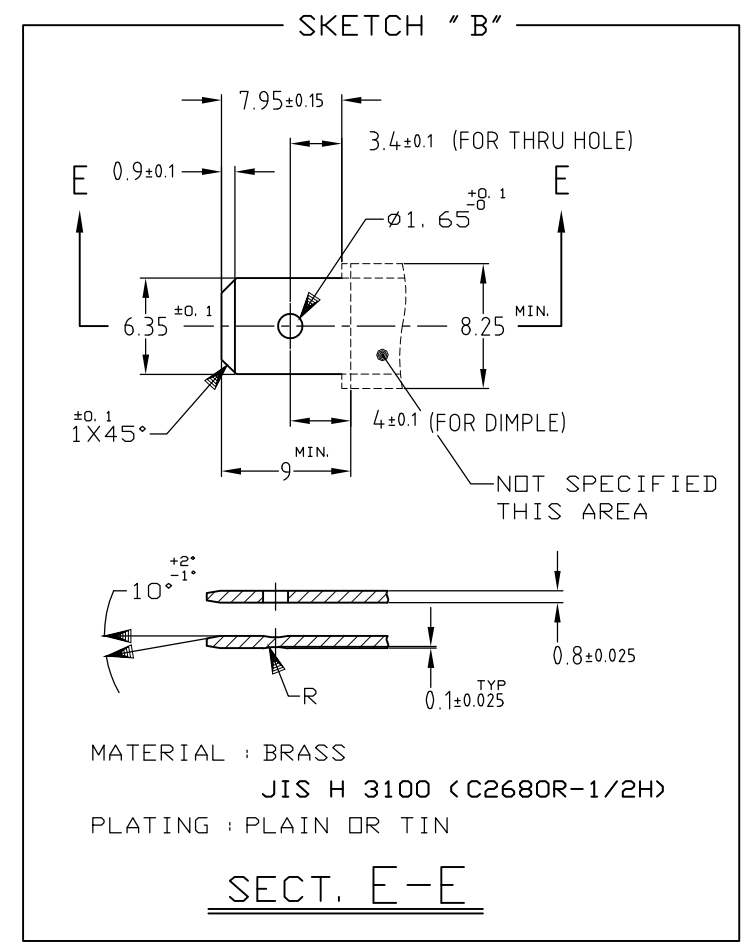
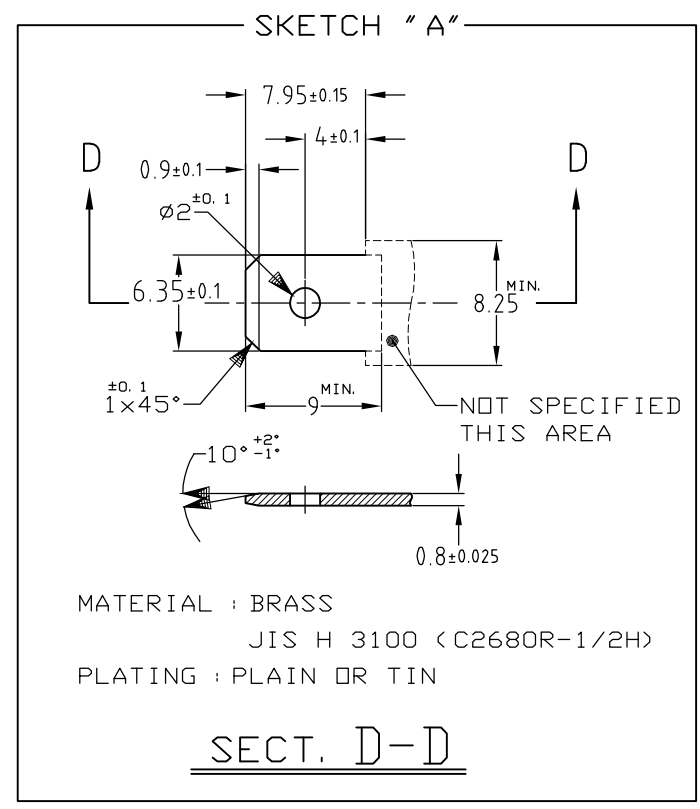

この寸法はかん合力によって管理する
THIS DIMENSION IS CONTROLLED WITH MATING FORCE

注;
1. ストレス除去処理
処理法により外観が変わります
不活性ガス加熱方式 --- 無光沢
大気加熱方式 --- 光沢

SEE SKETCH A	4.5	—	↑	170304-6
OBSOLETE	170323	—	TIN PLATING	170304-5
OBSOLETE	SEE SKETCH A	4.5	TIN PLATING	170304-4
OBSOLETE	SEE SKETCH B	3.8	—	170304-3
170302	—	—	—	170304-2
SEE SKETCH A	4.5	—	BRASS THICKNESS 黄銅 板厚 0.32t	170304-1
USE TAB 使用タブ	"A"	FINISH 仕上	MATERIAL 材料	PART NUMBER 型番

SECT. 断面 A-A

SECT. 断面 B-B

SECT. 断面 C-C

- NOTES;
- STRESS RELIEVING FINISH IS SUBJECT TO CHANGE BY THE TYPE OF STRESS RELIVING PROCESS
INERT GAS FURNACE --- MATTE
ATOMOSPERIC FURNACE FOLLOWD BY ACID PICKLE --- BRIGHT
 - SEPARATE PAPER TYPE

THIS DRAWING IS A CONTROLLED DOCUMENT.		DWN J.SATO	15MAY2007	Tyco Electronics AMP K.K. Kawasaki, Japan	
DIMENSIONS: 単位: 耗 mm		CHK S.MANABE	15MAY2007		
TOLERANCES UNLESS OTHERWISE SPECIFIED: 一般公差		APVD S.MANABE	15MAY2007	NAME 名称 .250 SERIES RECEPTACLE WITHOUT LATCH	
±0.4		PRODUCT SPEC 製品規格		SIZE A3	
MATERIAL 材料 SEE TABLE		APPLICATION SPEC 取付適用規格		CAGE CODE 00779	DRAWING NO 番号 G-170304
FINISH 仕上 SEE TABLE		WEIGHT		RESTRICTED TO —	
CUSTOMER DRAWING				SCALE 尺度 4:1	SHEET 1 OF 1
				REV D1	