

## Evaluating the **ADM1272** High Voltage Positive Hot Swap Controller and Digital Power Monitor with PMBus

### FEATURES

Fully functional support evaluation kit for the **ADM1272**  
Populated and tested with 48 V, 30 A, 1 mF design  
40 V undervoltage and 60 V overvoltage settings  
Custom N-MOSFET footprint suits different packages  
Supports up to 2 sense resistors in parallel  
Supports up to 4 FETs in parallel  
LED indicated status outputs  
Wide input voltage range: 16 V to 80 V  
120 V absolute maximum  
FET temperature measurement capability  
Supports cascade setup for multiple boards  
Toggle and push-button switch for easy input control  
PMBus (I<sup>2</sup>C) communication supported

### PACKAGE CONTENTS

**EVAL-ADM1272EBZ** evaluation board

### ADDITIONAL HARDWARE NEEDED

Serial input/output interface, **USB-SDP-CABLEZ** (not included in the evaluation kit, must be ordered separately)  
Only one dongle is required in multiple board cascade setup

### SOFTWARE NEEDED

Analog Devices, Inc., hot swap and power monitoring evaluation software (download from **ADM1272** product page)

### GENERAL DESCRIPTION

The **EVAL-ADM1272EBZ** is a compact, full featured evaluation board for the **ADM1272**. The board layout provides a clear visual of all the peripheral components and the hot swap power path. The layout also maximizes the ability of the board to dissipate heat for some of the key components on the power path, allowing the evaluation of high current hot swap setups.

Two sense resistor slots and four (two on the bottom side) multipackage FET slots provide great flexibility and allow a wide range of application setups.

Multiple test points allow easy access to all critical points and pins. Six LEDs provide direct visual indication on variations in the board status, such as supply input, output, GPIO1, GPIO2, power good, and fault.

The kit supports PMBus™ communication, allowing the user to communicate with the **ADM1272**. The evaluation kit also supports cascade setup so that multiple evaluation boards can be connected together and share the same PMBus.

The boards are fully compatible with the **ADM1272** evaluation software, which can be downloaded from the **ADM1272** product page.

A USB-to-I<sup>2</sup>C dongle (**USB-SDP-CABLEZ**) is required to use the evaluation software.

The standard evaluation kit is prepopulated and tested with a 48 V, 30 A hot swap design capable of working with a 1 mF output capacitor.

Complete specifications for the **ADM1272** are available in the **ADM1272** data sheet, which must be consulted in conjunction with this user guide when using the evaluation board.

**TABLE OF CONTENTS**

Features .....	1	MOSFETs.....	6
Package Contents.....	1	Sense Resistors.....	6
Additional Hardware Needed .....	1	Board Specifications.....	6
Software Needed.....	1	Evaluation Board Hardware.....	7
General Description .....	1	Connector, Switch, and LED Functions .....	7
Revision History .....	2	Evaluation Board Schematics and Artwork.....	8
Evaluation Board Photograph.....	3	Ordering Information.....	11
Quick Start Guide.....	4	Bill of Materials.....	11
Evaluation Board Description.....	5	Related Links.....	12
Configuration.....	5		

**REVISION HISTORY**

4/2017—Revision 0: Initial Version

### EVALUATION BOARD PHOTOGRAPH

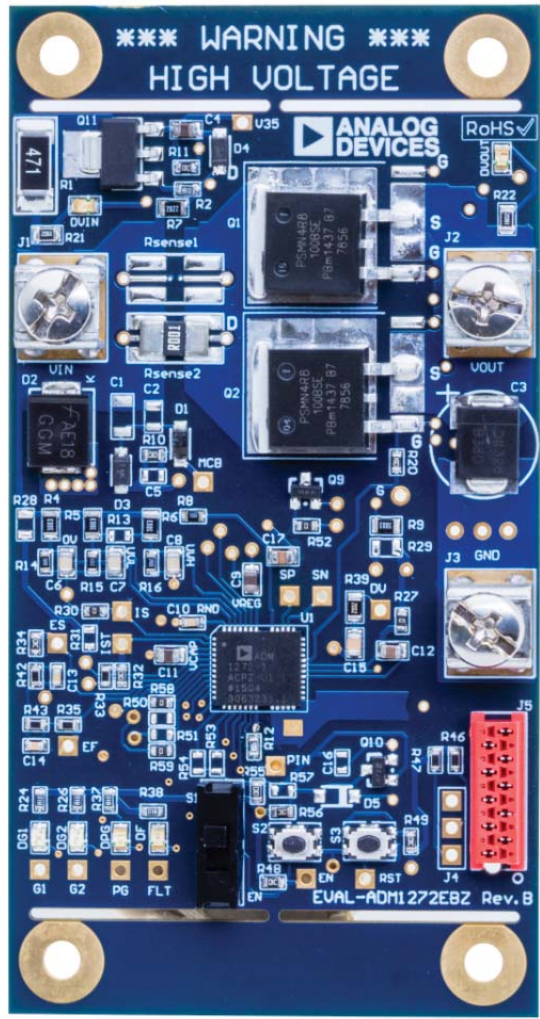

Figure 1.

14541-001

## QUICK START GUIDE

To set up and start using the evaluation board, take the following steps:

1. Download the hot swap and power monitoring software from the [ADM1272](#) product page (see the [UG-353](#) for more information).
2. Connect the evaluation board ([EVAL-ADM1272EBZ](#)) to a PC through the 10-way connector and the USB-to-I<sup>2</sup>C dongle ([USB-SDP-CABLEZ](#)).
3. Connect the power supply to the evaluation board using thick wires suitable for the current levels to be observed.
4. To confirm that the boards are configured correctly, set the output of the power supply to 48 V with less than 1 A current limit and with no load capacitance. If the boards are configured correctly, the green LED (labeled PWRGD) on the evaluation board illuminates.
5. Push the ENABLE switch to the off position or press the push button on the evaluation board. The green LED (labeled PWRGD) turns off and then turns back on again when reenabled.
6. The restart signal can be provided using the RST switch (S3). Pressing this switch disables the output, and it is automatically reenabled after the restart time has elapsed (default is approximately 10 sec).
7. If a fault event occurs (for example, a short circuit during operation), the red LED (labeled FAULT) illuminates. This fault can be cleared by toggling the ENABLE pin after the fault condition has been removed.
8. Disable the hot swap using the **Hot Swap Control** section in the **Basic Operation** tab of the software graphical user interface (GUI). Disabling the hot swap turns off the green LED (labeled PWRGD) on the evaluation board.
9. Manually program the sense resistor value, if required, using the options in the GUI.
10. Check that the voltage and current measurements are as expected (for example, VIN = 48 V) in the **Power Monitor** tab of the software GUI.

## EVALUATION BOARD DESCRIPTION

The [EVAL-ADM1272EBZ](#) evaluation board is designed to demonstrate several features of the [ADM1272](#). A simplified diagram of the evaluation board is shown in Figure 2.

The evaluation board is connected to a PC using a USB-to-I<sup>2</sup>C dongle ([USB-SDP-CABLEZ](#)) for PMBus communication. The evaluation board is shown in Figure 1.

To minimize inductance and losses, use appropriately rated wires between the power supply, the evaluation board connectors, and the load. There is only one GND connector, so the main system current does not normally flow through the evaluation board.

## CONFIGURATION

The [EVAL-ADM1272EBZ](#) evaluation board is configured to operate between 40 V and 60 V, with a current limit of 30 A. Loads with up to 1000  $\mu$ F of capacitance can be connected. This capacitance is not included on the board, because it is intended to be plugged into a system where load capacitance already exists. If load capacitance does not already exist, add capacitance across the load using the J2 (VOUT) and J3 (GND) connectors, or solder across D6 and/or on the bottom side pads under D6. To prevent faults at power up, take care to avoid any dc loads being enabled until after PWRGD is asserted.

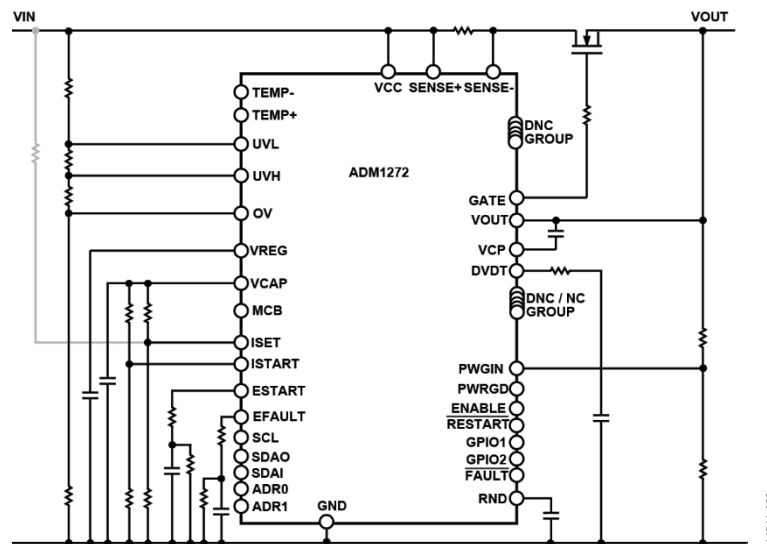

Figure 2. Basic [ADM1272](#) Connection Diagram

**MOSFETS**

The EVAL-ADM1272EBZ uses a custom MOSFET footprint, shown in Figure 3, to accommodate a variety of common MOSFET packages. Examples include D2PAK, DPAK, LFPAK, and other SO-8 variants.

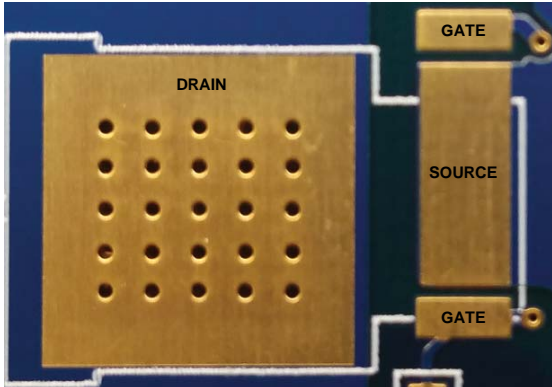

Figure 3. Multipackage N-Channel MOSFET Footprint

**SENSE RESISTORS**

For optimum current sensing accuracy with standard 2512 sense resistors, the footprint shown in Figure 4 is preferred. This footprint may not be optimized to all resistors, and results may vary depending on resistor composition and size.

The center pads are used as the Kelvin connection to sense the voltage at the resistor. Some resistors provide more accurate results if sensed at the outer edge of the resistor (labeled A in Figure 4). Alternatively, the user can configure the sense connections to be made through center locations (labeled B in Figure 4), which may yield better results for certain resistor types. The board can be configured through the eight resistors located on the underside of the printed circuit board (PCB), directly under the sense resistors. R7O, R8O, R17O, and R18O connect the outside vias (labeled A in Figure 4), and R7I, R8I, R17I, and R18I connect the inside vias (labeled B in Figure 4). The outside vias are connected by default.

Sense resistors must be tested independently. It is the responsibility of the user to ensure that the layout dimensions and structure of the footprint comply with individual SMT manufacturing requirements.

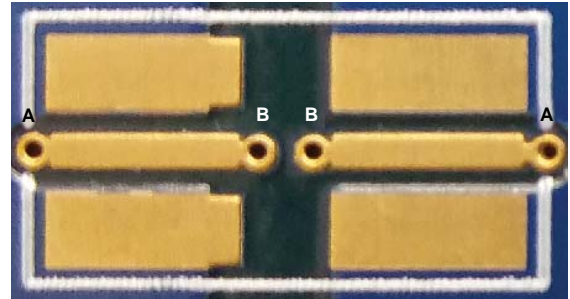

Figure 4. Sense Resistor—Kelvin Footprint

**BOARD SPECIFICATIONS**

Table 1.

Parameter	Typical Value	Unit
Load Capacitance	1000	μF
Severe Circuit Breaker Current	60	A
Normal Current Limit	30	A
Start-Up Current Limit	4	A
Maximum Ambient Temperature	60	°C
Undervoltage (UV) Falling Threshold (UVL)	39.7	V
UV Rising Threshold (UVH)	41.2	V
Overvoltage (OV) Rising Threshold	60	V
PWRGD Falling Threshold	40.2	V

## EVALUATION BOARD HARDWARE

### CONNECTOR, SWITCH, AND LED FUNCTIONS

Table 2. Connector Functions

Connector	Description
J1	Hot swap line voltage input, which also powers the board. Input voltage is 40 V to 60 V.
J2	Hot swap line voltage output. Connect to load.
J3	GND connector.
J4	Can be used to connect PMBus nodes to system host or dongle. Pin 1 is SCL. Pin 2 is SDA. Pin 3 is GND (top).
J5	10-way connector for <a href="#">USB-SDP-CABLEZ</a> PMBus connection.

Table 3. Switch Functions

Switch	Description
S1	Toggle switch for the ENABLE pin. Up means on.
S2	Push-button switch for the ENABLE pin. Push to reset.
S3	Push-button switch for the $\overline{\text{RESTART}}$ pin. Push to disable the output and automatically reenable after the restart time has elapsed (default is approximately 10 sec).

Table 4. LED Functions

LED	Description
DVIN	Board input power; green.
DVOUT	Board output power; green.
DPG	Power good; green (LED on means PWRGD high).
DF	$\overline{\text{FAULT}}$ ; red (LED on means $\overline{\text{FAULT}}$ low).
DG1	GPO1; blue (LED on means GPIO1 high).
DG2	GPO2; blue (LED on means GPIO2 high).

# EVALUATION BOARD SCHEMATICS AND ARTWORK

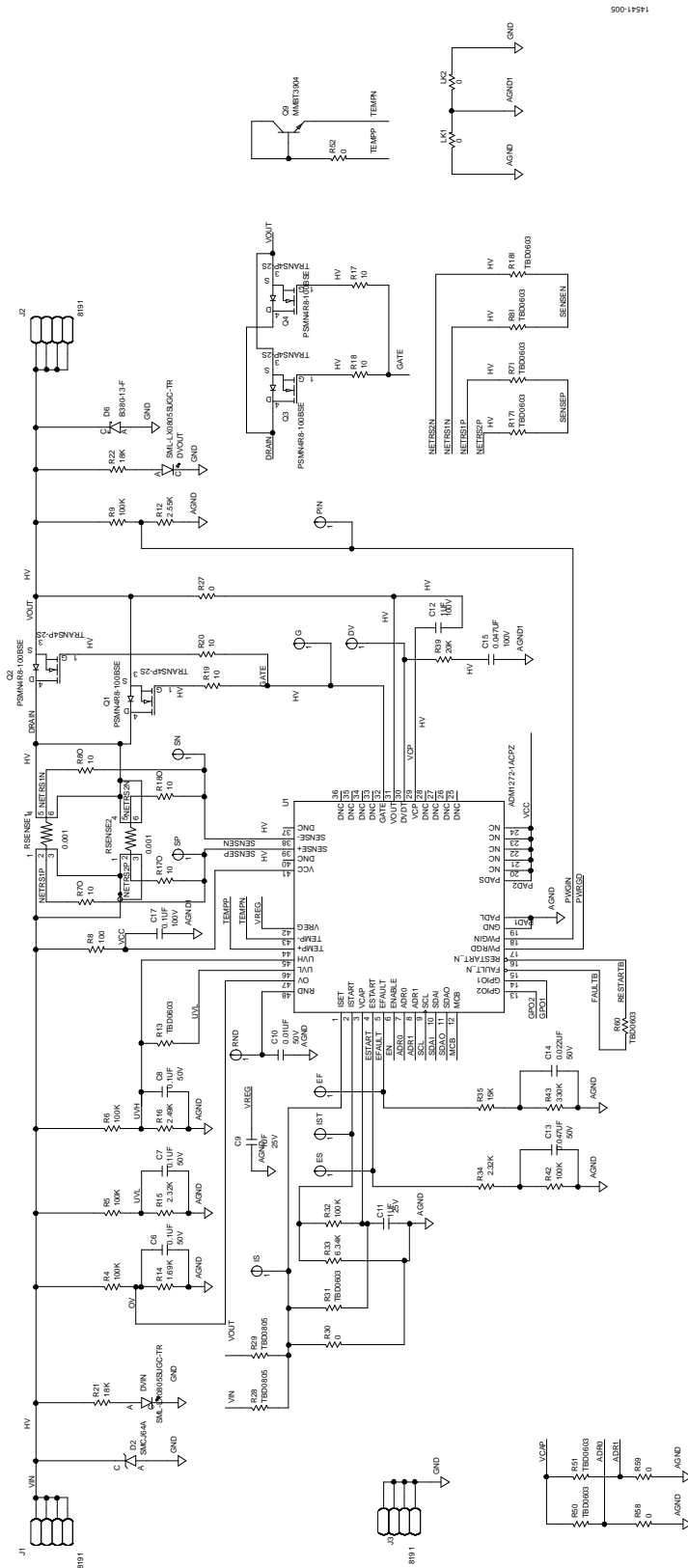

Figure 5. Evaluation Board Schematic—Main Circuitry



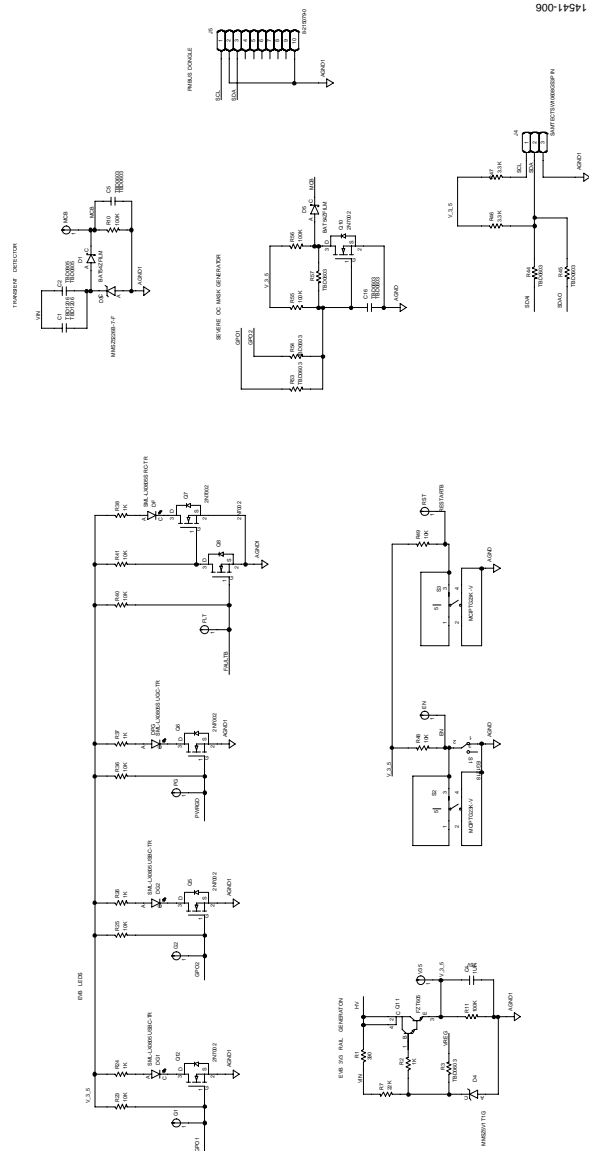

Figure 6. Evaluation Board Schematic—Connectors and Miscellaneous

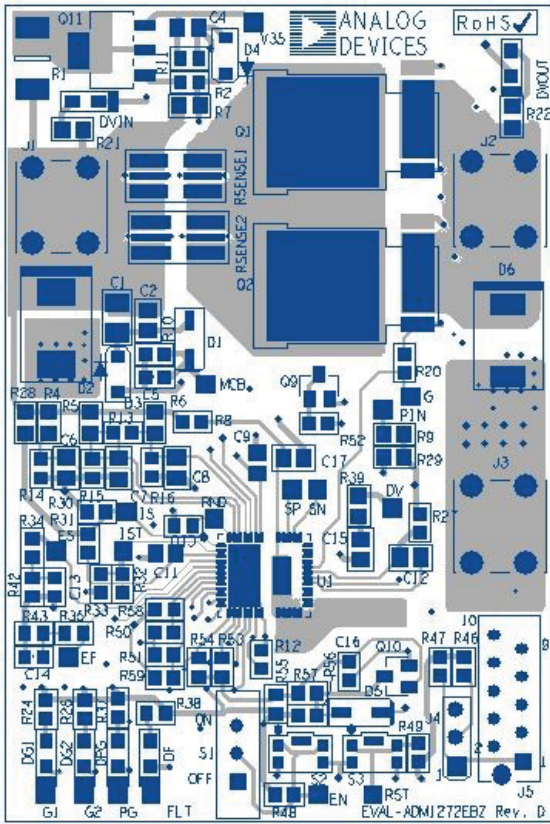

Figure 7. Top Layer 1

14541-007

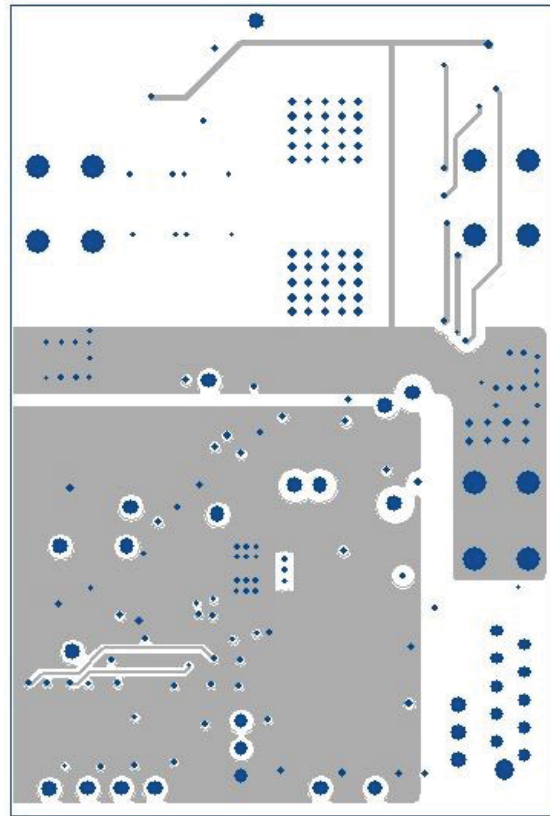

Figure 9. Inner Layer 3

14541-009

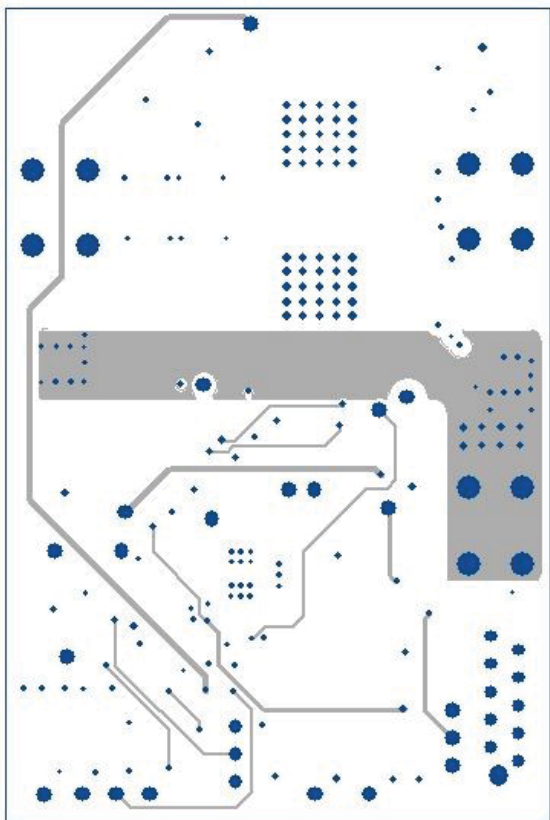

Figure 8. Inner Layer 2

14541-008

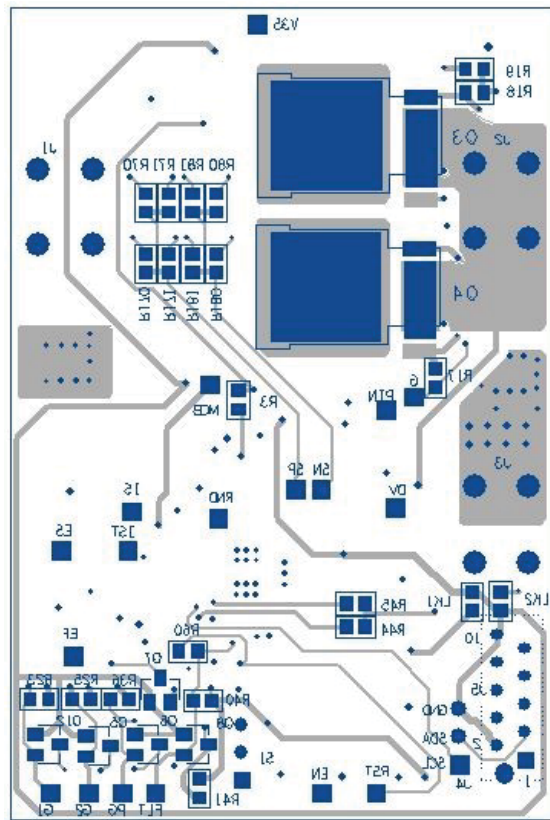

Figure 10. Bottom Layer

14541-010

# ORDERING INFORMATION

## BILL OF MATERIALS

Table 5.

Reference Designator	Description	Manufacturer/Part Number
C1	Do not install (C1206)	Not applicable
C2	Do not install (C0805)	Not applicable
C4, C9, C11	Capacitor, chip, ceramic, X7R	Murata, GCM21BR71E105KA56L
C5, C16	Do not install (C0603)	Not applicable
C6 to C8	Capacitor, ceramic, X7R	Kemet, C0805C104J5RACTU
C10	Capacitor, ceramic, X7R	Murata, GRM188R71H103KA01D
C12	Capacitor, ceramic, X7S	TDK, C2012X7S2A105K125AB
C13	Capacitor, ceramic, 0603, X7R	Kemet, C0603X473K5RAC7867
C14	Capacitor, ceramic, X7R, 0603, 16 V, 10%	Yageo, 06035C223KAZ2A
C15	Capacitor, ceramic, X7R, commercial grade	Kemet, C0805C473K1RACTU
C17	Capacitor, ceramic, X7R	AVX, 08051C104JAT2A
D1, D5	Do not install (diode, Schottky)	STMicroelectronics, BAT54ZFILM
D2	Diode, TVS, unidirectional	Littelfuse, Inc., SMCJ64A
D3	Diode, Zener	Diodes, Inc., MMSZ5226B-7-F
D4	Diode, Zener, voltage regulator	ON Semiconductor, MMSZ5V1T1G
D6	Diode, Schottky, barrier rectifier, 3.0 A	Diodes, Inc., B380-13-F
DF	Diode, LED, red, clear, 660 nm wavelength peak	Lumex, Inc., SML-LX0805SRC-TR
DG1, DG2	Diode, LED, blue, clear, 470 nm wavelength peak	Lumex, Inc., SML-LX0805USBC-TR
DPG, DVIN, DVOUT	LED, super ultragreen, water clear lens	Lumex, Inc., SML-LX0805SUGC-TR
G, DV, EF, EN, ES, G1, G2, IS, PG, SN, SP, FLT, IST, MCB, PIN, RND, RST, V35	Do not install (connector, PCB, PC board pin)	Not applicable
J1 to J3	Connector, PCB, screw terminal, vertical	Keystone, 8191
J4	Connector, PCB, Berg, header, straight, male, 3-pin	Samtec, TSW-103-08-G-S
J5	Connector, PCB, board to board and mezzanine, micromatch	TE Connectivity, 8-215079-0
LK1, LK2, R27, R30, R52, R58, R59, R44, R45	Resistor, film, SMD, 0603	Yageo, RC0603FR-072K49L
Q1, Q2	Transistor, N-channel, MOSFET, 0.0048 Ω, RDS-ON	NXP Semiconductors, PSMN4R8-100BSE
Q3, Q4	Do not install	NXP Semiconductors, PSMN4R8-100BSE
Q5 to Q8, Q10, Q12	Transistor, N-channel, enhance mode, FET	Fairchild, 2N7002
Q11	Transistor, NPN, Darlington	Diodes, Inc., FZT605
Q9	Transistor, MMBT3904, NPN, SOT-23	Fairchild, MMBT3904
R1	Resistor, power, SMD, 3520 series, 5%, 1 W, 2512	TE Connectivity, 3520390RJT
R10, R11, R32	Resistor, precision, thick film, chip	Panasonic, ERJ-3EKF1003V
R55, R56	Do not install	Panasonic, ERJ-3EKF1003V
R12	Resistor, metal film, high reliability	Panasonic, ERA-3AEB2551V
R3, R13, R31, R44, R45, R50, R51, R53, R54, R57, R60, R71, R81, R171, R181	Do not install (R0603)	Not applicable
R14	Resistor, film, SMD 0603	Panasonic, ERJ-3EKF1691V
R15, R34	Resistor, precision, thick film, chip, R0603	Panasonic, ERJ-3EKF2321V
R16	Resistor, general-purpose, chip	Yageo, RC0603FR-072K49L
R17 to R20, R70, R80, R170, R180	Resistor, precision, thick film, chip, R0603	Panasonic, ERJ-3EKF10R0V
R2, R24, R26, R37, R38	Resistor, precision, thick film, chip, R0603	Panasonic, ERJ-3EKF1001V
R21, R22	Resistor, metal film, chip	Panasonic, ERA-6AEB183V
R23, R25, R36, R40, R41, R48, R49	Resistor, thick film, chip	Panasonic, ERJ-3EKF1002V
R28, R29	Do not install (R0805)	Not applicable
R33	Resistor, precision, thick film, chip, R0603	Vishay, CRCW06036R34FKEA
R35	Resistor, metal film, high reliability	Panasonic, ERA-3YEB153V
R39	Resistor, film, SMD, 0805	Meggit, RN73C2A20KBTDF
R4 to R6, R9	Resistor, precision, thick film, chip, R0805	Panasonic, ERJ-6ENF1003V

Reference Designator	Description	Manufacturer/Part Number
R42	Do not install (R0603)	Not applicable
R43	Resistor, film, SMD, 0603	Susumi, RR0816P-334-D
R46, R47	Resistor, film, SMD, 0603	Panasonic, ERJ-3EKF3301V
R7	Resistor, film, SMD, 0805	Panasonic, ERJ-6ENF2202V
R8	Resistor, precision, thick film, chip, R0603	Panasonic, ERJ-3EKF1000V
RSENSE2	Resistor, customized pad layout of metal element current sense	TT Electronics, ULRG32512R001FLFSLT
RSENSE1	Do not install	Not applicable
S1	Switch, PC mount, slide switch	E-Switch, EG1218
S2, S3	Switch, tactile, SPST-NO	C&K Components, KMR211GLFS
U1	IC, high voltage positive swap controller and digital power monitor with PMBus	Analog Devices, Inc., <a href="#">ADM1272-1ACPZ</a>

## RELATED LINKS

Resource	Description
<a href="#">ADM1272</a>	Product Page, High Voltage Positive Hot Swap Controller and Digital Power Monitor with PMBus

I<sup>2</sup>C refers to a communications protocol originally developed by Philips Semiconductors (now NXP Semiconductors).



### ESD Caution

**ESD (electrostatic discharge) sensitive device.** Charged devices and circuit boards can discharge without detection. Although this product features patented or proprietary protection circuitry, damage may occur on devices subjected to high energy ESD. Therefore, proper ESD precautions should be taken to avoid performance degradation or loss of functionality.

### Legal Terms and Conditions

By using the evaluation board discussed herein (together with any tools, components documentation or support materials, the "Evaluation Board"), you are agreeing to be bound by the terms and conditions set forth below ("Agreement") unless you have purchased the Evaluation Board, in which case the Analog Devices Standard Terms and Conditions of Sale shall govern. Do not use the Evaluation Board until you have read and agreed to the Agreement. Your use of the Evaluation Board shall signify your acceptance of the Agreement. This Agreement is made by and between you ("Customer") and Analog Devices, Inc. ("ADI"), with its principal place of business at One Technology Way, Norwood, MA 02062, USA. Subject to the terms and conditions of the Agreement, ADI hereby grants to Customer a free, limited, personal, temporary, non-exclusive, non-sublicensable, non-transferable license to use the Evaluation Board FOR EVALUATION PURPOSES ONLY. Customer understands and agrees that the Evaluation Board is provided for the sole and exclusive purpose referenced above, and agrees not to use the Evaluation Board for any other purpose. Furthermore, the license granted is expressly made subject to the following additional limitations: Customer shall not (i) rent, lease, display, sell, transfer, assign, sublicense, or distribute the Evaluation Board; and (ii) permit any Third Party to access the Evaluation Board. As used herein, the term "Third Party" includes any entity other than ADI, Customer, their employees, affiliates and in-house consultants. The Evaluation Board is NOT sold to Customer; all rights not expressly granted herein, including ownership of the Evaluation Board, are reserved by ADI. CONFIDENTIALITY. This Agreement and the Evaluation Board shall all be considered the confidential and proprietary information of ADI. Customer may not disclose or transfer any portion of the Evaluation Board to any other party for any reason. Upon discontinuation of use of the Evaluation Board or termination of this Agreement, Customer agrees to promptly return the Evaluation Board to ADI. ADDITIONAL RESTRICTIONS. Customer may not disassemble, decompile or reverse engineer chips on the Evaluation Board. Customer shall inform ADI of any occurred damages or any modifications or alterations it makes to the Evaluation Board, including but not limited to soldering or any other activity that affects the material content of the Evaluation Board. Modifications to the Evaluation Board must comply with applicable law, including but not limited to the RoHS Directive. TERMINATION. ADI may terminate this Agreement at any time upon giving written notice to Customer. Customer agrees to return to ADI the Evaluation Board at that time. LIMITATION OF LIABILITY. THE EVALUATION BOARD PROVIDED HEREUNDER IS PROVIDED "AS IS" AND ADI MAKES NO WARRANTIES OR REPRESENTATIONS OF ANY KIND WITH RESPECT TO IT. ADI SPECIFICALLY DISCLAIMS ANY REPRESENTATIONS, ENDORSEMENTS, GUARANTEES, OR WARRANTIES, EXPRESS OR IMPLIED, RELATED TO THE EVALUATION BOARD INCLUDING, BUT NOT LIMITED TO, THE IMPLIED WARRANTY OF MERCHANTABILITY, TITLE, FITNESS FOR A PARTICULAR PURPOSE OR NON-INFRINGEMENT OF INTELLECTUAL PROPERTY RIGHTS. IN NO EVENT WILL ADI AND ITS LICENSORS BE LIABLE FOR ANY INCIDENTAL, SPECIAL, INDIRECT, OR CONSEQUENTIAL DAMAGES RESULTING FROM CUSTOMER'S POSSESSION OR USE OF THE EVALUATION BOARD, INCLUDING BUT NOT LIMITED TO LOST PROFITS, DELAY COSTS, LABOR COSTS OR LOSS OF GOODWILL. ADI'S TOTAL LIABILITY FROM ANY AND ALL CAUSES SHALL BE LIMITED TO THE AMOUNT OF ONE HUNDRED US DOLLARS (\$100.00). EXPORT. Customer agrees that it will not directly or indirectly export the Evaluation Board to another country, and that it will comply with all applicable United States federal laws and regulations relating to exports. GOVERNING LAW. This Agreement shall be governed by and construed in accordance with the substantive laws of the Commonwealth of Massachusetts (excluding conflict of law rules). Any legal action regarding this Agreement will be heard in the state or federal courts having jurisdiction in Suffolk County, Massachusetts, and Customer hereby submits to the personal jurisdiction and venue of such courts. The United Nations Convention on Contracts for the International Sale of Goods shall not apply to this Agreement and is expressly disclaimed.