

## Solder Instruction <sup>(b)</sup>

1. Cable should be prepared for soldering. The cable/wires must be pretinned.
2. Insert cable/wire into solder cup.
3. Operate the soldering iron at 350°C, 50 Watt max. and use a pencil tip.
4. Put tip to wire in solder cup.
5. After 1 second bring in solder.
6. Heat for 3 seconds longer. Do not heat contact more than 4 seconds in total.
7. Remove soldering iron.
8. Wait until solder gets rigid again.
9. Do not solder adjacent contacts consecutively, alternate position within the connector to minimize heat build up.

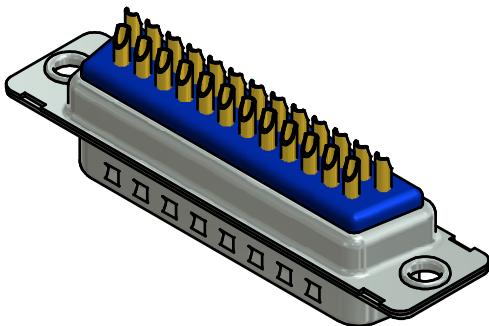
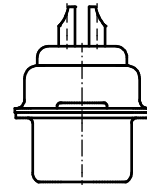
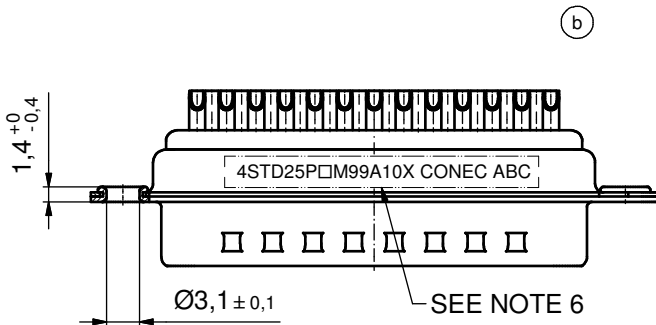
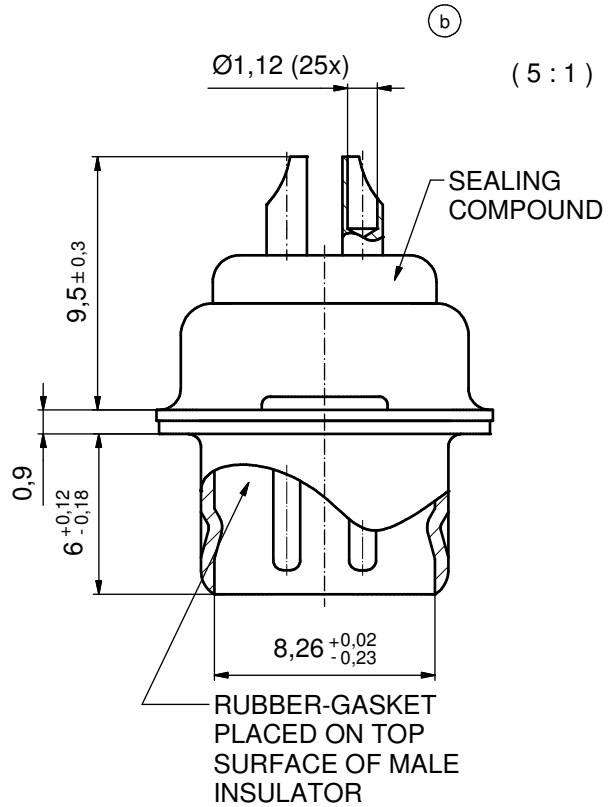
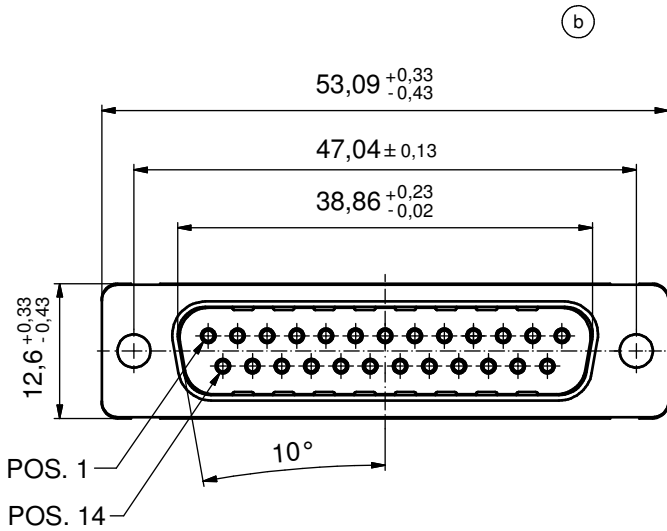

## NOTES: <sup>(b)</sup>

1. METAL SHELLS: COPPER ALLOY; min. 315µm TIN over 40-80µm NICKEL
2. INSULATORS: PBT GF UL 94 V-0; BLACK
3. SIGNAL CONTACTS: COPPER ALLOY; PLATING (SEE PART NO.)
  - PLEASE ADD C for 30µm HARD GOLD over min. 50µm NICKEL
  - PLEASE ADD B for 20µm HARD GOLD over min. 50µm NICKEL
  - PLEASE ADD A for GOLD FLASH over NICKEL (PREFERRED TYPE)
4. SEALING COMPOUND: PUR; BLUE
5. RUBBER-GASKET: TPE; BLACK
6. CONNECTOR IS PART MARKED: 4STD25P□M99A10X CONEC ABC (see note 3)

Directive 2002/95/EC RoHS compliant

THIS DRAWING MAY NOT BE COPIED OR REPRODUCED IN ANY WAY, AND MAY NOT BE PASSED ON TO A THIRD PARTY WITHOUT WRITTEN PERMISSION. OWNERSHIP AND COPYRIGHT OF CONEC GmbH  DO NOT ALTER CAD DRAWING BY HAND				tolerance	dim. in mm	scale: 2:1 (5:1)	
				date		name	material: SEE NOTES
				drawn	22.08.12	Henneboel	title: <b>D-SUB MALE</b> 25pos. SOLDER CUP for installation into water resistant hood
				appd.	22.08.12	Fischer	
				norm			
				d-old	18K11B3A/18K1A232		dwg no:
6 x b	Ä4434	22.08.2012	K.H.			15K1A1134 <sup>(b)</sup>	DIN-A3
a	Original					sh: 1	
rev.	description	date	name	part no: 4STD25P□M99A10X (see note 3)			