

To our customers,

Old Company Name in Catalogs and Other Documents

On April 1st, 2010, NEC Electronics Corporation merged with Renesas Technology Corporation, and Renesas Electronics Corporation took over all the business of both companies. Therefore, although the old company name remains in this document, it is a valid Renesas Electronics document. We appreciate your understanding.

Renesas Electronics website: <http://www.renesas.com>

April 1st, 2010
Renesas Electronics Corporation

Issued by: Renesas Electronics Corporation (<http://www.renesas.com>)

Send any inquiries to <http://www.renesas.com/inquiry>.

Notice

1. All information included in this document is current as of the date this document is issued. Such information, however, is subject to change without any prior notice. Before purchasing or using any Renesas Electronics products listed herein, please confirm the latest product information with a Renesas Electronics sales office. Also, please pay regular and careful attention to additional and different information to be disclosed by Renesas Electronics such as that disclosed through our website.
2. Renesas Electronics does not assume any liability for infringement of patents, copyrights, or other intellectual property rights of third parties by or arising from the use of Renesas Electronics products or technical information described in this document. No license, express, implied or otherwise, is granted hereby under any patents, copyrights or other intellectual property rights of Renesas Electronics or others.
3. You should not alter, modify, copy, or otherwise misappropriate any Renesas Electronics product, whether in whole or in part.
4. Descriptions of circuits, software and other related information in this document are provided only to illustrate the operation of semiconductor products and application examples. You are fully responsible for the incorporation of these circuits, software, and information in the design of your equipment. Renesas Electronics assumes no responsibility for any losses incurred by you or third parties arising from the use of these circuits, software, or information.
5. When exporting the products or technology described in this document, you should comply with the applicable export control laws and regulations and follow the procedures required by such laws and regulations. You should not use Renesas Electronics products or the technology described in this document for any purpose relating to military applications or use by the military, including but not limited to the development of weapons of mass destruction. Renesas Electronics products and technology may not be used for or incorporated into any products or systems whose manufacture, use, or sale is prohibited under any applicable domestic or foreign laws or regulations.
6. Renesas Electronics has used reasonable care in preparing the information included in this document, but Renesas Electronics does not warrant that such information is error free. Renesas Electronics assumes no liability whatsoever for any damages incurred by you resulting from errors in or omissions from the information included herein.
7. Renesas Electronics products are classified according to the following three quality grades: "Standard", "High Quality", and "Specific". The recommended applications for each Renesas Electronics product depends on the product's quality grade, as indicated below. You must check the quality grade of each Renesas Electronics product before using it in a particular application. You may not use any Renesas Electronics product for any application categorized as "Specific" without the prior written consent of Renesas Electronics. Further, you may not use any Renesas Electronics product for any application for which it is not intended without the prior written consent of Renesas Electronics. Renesas Electronics shall not be in any way liable for any damages or losses incurred by you or third parties arising from the use of any Renesas Electronics product for an application categorized as "Specific" or for which the product is not intended where you have failed to obtain the prior written consent of Renesas Electronics. The quality grade of each Renesas Electronics product is "Standard" unless otherwise expressly specified in a Renesas Electronics data sheets or data books, etc.

"Standard": Computers; office equipment; communications equipment; test and measurement equipment; audio and visual equipment; home electronic appliances; machine tools; personal electronic equipment; and industrial robots.

"High Quality": Transportation equipment (automobiles, trains, ships, etc.); traffic control systems; anti-disaster systems; anti-crime systems; safety equipment; and medical equipment not specifically designed for life support.

"Specific": Aircraft; aerospace equipment; submersible repeaters; nuclear reactor control systems; medical equipment or systems for life support (e.g. artificial life support devices or systems), surgical implantations, or healthcare intervention (e.g. excision, etc.), and any other applications or purposes that pose a direct threat to human life.

8. You should use the Renesas Electronics products described in this document within the range specified by Renesas Electronics, especially with respect to the maximum rating, operating supply voltage range, movement power voltage range, heat radiation characteristics, installation and other product characteristics. Renesas Electronics shall have no liability for malfunctions or damages arising out of the use of Renesas Electronics products beyond such specified ranges.
9. Although Renesas Electronics endeavors to improve the quality and reliability of its products, semiconductor products have specific characteristics such as the occurrence of failure at a certain rate and malfunctions under certain use conditions. Further, Renesas Electronics products are not subject to radiation resistance design. Please be sure to implement safety measures to guard them against the possibility of physical injury, and injury or damage caused by fire in the event of the failure of a Renesas Electronics product, such as safety design for hardware and software including but not limited to redundancy, fire control and malfunction prevention, appropriate treatment for aging degradation or any other appropriate measures. Because the evaluation of microcomputer software alone is very difficult, please evaluate the safety of the final products or system manufactured by you.
10. Please contact a Renesas Electronics sales office for details as to environmental matters such as the environmental compatibility of each Renesas Electronics product. Please use Renesas Electronics products in compliance with all applicable laws and regulations that regulate the inclusion or use of controlled substances, including without limitation, the EU RoHS Directive. Renesas Electronics assumes no liability for damages or losses occurring as a result of your noncompliance with applicable laws and regulations.
11. This document may not be reproduced or duplicated, in any form, in whole or in part, without prior written consent of Renesas Electronics.
12. Please contact a Renesas Electronics sales office if you have any questions regarding the information contained in this document or Renesas Electronics products, or if you have any other inquiries.

(Note 1) "Renesas Electronics" as used in this document means Renesas Electronics Corporation and also includes its majority-owned subsidiaries.

(Note 2) "Renesas Electronics product(s)" means any product developed or manufactured by or for Renesas Electronics.

The revision list can be viewed directly by clicking the title page.

The revision list summarizes the locations of revisions and additions. Details should always be checked by referring to the relevant text.

H8/36912 Group, H8/36902 Group

Hardware Manual

Renesas 16-Bit Single-Chip Microcomputer
H8 Family/H8/300H Tiny Series

H8/36912F	HD64F36912G
H8/36902F	HD64F36902G
H8/36912	HD64336912G
H8/36911	HD64336911G
H8/36902	HD64336902G
H8/36901	HD64336901G
H8/36900	HD64336900G

Keep safety first in your circuit designs!

1. Renesas Technology Corp. puts the maximum effort into making semiconductor products better and more reliable, but there is always the possibility that trouble may occur with them. Trouble with semiconductors may lead to personal injury, fire or property damage.
Remember to give due consideration to safety when making your circuit designs, with appropriate measures such as (i) placement of substitutive, auxiliary circuits, (ii) use of nonflammable material or (iii) prevention against any malfunction or mishap.

Notes regarding these materials

1. These materials are intended as a reference to assist our customers in the selection of the Renesas Technology Corp. product best suited to the customer's application; they do not convey any license under any intellectual property rights, or any other rights, belonging to Renesas Technology Corp. or a third party.
2. Renesas Technology Corp. assumes no responsibility for any damage, or infringement of any third-party's rights, originating in the use of any product data, diagrams, charts, programs, algorithms, or circuit application examples contained in these materials.
3. All information contained in these materials, including product data, diagrams, charts, programs and algorithms represents information on products at the time of publication of these materials, and are subject to change by Renesas Technology Corp. without notice due to product improvements or other reasons. It is therefore recommended that customers contact Renesas Technology Corp. or an authorized Renesas Technology Corp. product distributor for the latest product information before purchasing a product listed herein.
The information described here may contain technical inaccuracies or typographical errors. Renesas Technology Corp. assumes no responsibility for any damage, liability, or other loss rising from these inaccuracies or errors.
Please also pay attention to information published by Renesas Technology Corp. by various means, including the Renesas Technology Corp. Semiconductor home page (<http://www.renesas.com>).
4. When using any or all of the information contained in these materials, including product data, diagrams, charts, programs, and algorithms, please be sure to evaluate all information as a total system before making a final decision on the applicability of the information and products. Renesas Technology Corp. assumes no responsibility for any damage, liability or other loss resulting from the information contained herein.
5. Renesas Technology Corp. semiconductors are not designed or manufactured for use in a device or system that is used under circumstances in which human life is potentially at stake. Please contact Renesas Technology Corp. or an authorized Renesas Technology Corp. product distributor when considering the use of a product contained herein for any specific purposes, such as apparatus or systems for transportation, vehicular, medical, aerospace, nuclear, or undersea repeater use.
6. The prior written approval of Renesas Technology Corp. is necessary to reprint or reproduce in whole or in part these materials.
7. If these products or technologies are subject to the Japanese export control restrictions, they must be exported under a license from the Japanese government and cannot be imported into a country other than the approved destination.
Any diversion or reexport contrary to the export control laws and regulations of Japan and/or the country of destination is prohibited.
8. Please contact Renesas Technology Corp. for further details on these materials or the products contained therein.

General Precautions on Handling of Product

1. Treatment of NC Pins

Note: Do not connect anything to the NC pins.

The NC (not connected) pins are either not connected to any of the internal circuitry or are used as test pins or to reduce noise. If something is connected to the NC pins, the operation of the LSI is not guaranteed.

2. Treatment of Unused Input Pins

Note: Fix all unused input pins to high or low level.

Generally, the input pins of CMOS products are high-impedance input pins. If unused pins are in their open states, intermediate levels are induced by noise in the vicinity, a pass-through current flows internally, and a malfunction may occur.

3. Processing before Initialization

Note: When power is first supplied, the product's state is undefined.

The states of internal circuits are undefined until full power is supplied throughout the chip and a low level is input on the reset pin. During the period where the states are undefined, the register settings and the output state of each pin are also undefined. Design your system so that it does not malfunction because of processing while it is in this undefined state. For those products which have a reset function, reset the LSI immediately after the power supply has been turned on.

4. Prohibition of Access to Undefined or Reserved Addresses

Note: Access to undefined or reserved addresses is prohibited.

The undefined or reserved addresses may be used to expand functions, or test registers may have been allocated to these addresses. Do not access these registers; the system's operation is not guaranteed if they are accessed.

Configuration of This Manual

This manual comprises the following items:

1. General Precautions on Handling of Product
2. Configuration of This Manual
3. Preface
4. Contents
5. Overview
6. Description of Functional Modules
 - CPU and System-Control Modules
 - On-Chip Peripheral Modules

The configuration of the functional description of each module differs according to the module. However, the generic style includes the following items:

 - i) Feature
 - ii) Input/Output Pin
 - iii) Register Description
 - iv) Operation
 - v) Usage Note

When designing an application system that includes this LSI, take notes into account. Each section includes notes in relation to the descriptions given, and usage notes are given, as required, as the final part of each section.

7. List of Registers
8. Electrical Characteristics
9. Appendix
10. Main Revisions and Additions in this Edition (only for revised versions)

The list of revisions is a summary of points that have been revised or added to earlier versions. This does not include all of the revised contents. For details, see the actual locations in this manual.

11. Index

Preface

The H8/36912 Group and H8/36902 Group are single-chip microcomputers made up of the high-speed H8/300H CPU employing Renesas Technology original architecture as their cores, and the peripheral functions required to configure a system. The H8/300H CPU has an instruction set that is compatible with the H8/300 CPU.

Target Users: This manual was written for users who will be using the H8/36912 Group and H8/36902 Group in the design of application systems. Target users are expected to understand the fundamentals of electrical circuits, logical circuits, and microcomputers.

Objective: This manual was written to explain the hardware functions and electrical characteristics of the H8/36912 Group and H8/36902 Group to the target users. Refer to the H8/300H Series Software Manual for a detailed description of the instruction set.

Notes on reading this manual:

- In order to understand the overall functions of the chip
Read the manual according to the contents. This manual can be roughly categorized into parts on the CPU, system control functions, peripheral functions and electrical characteristics.
- In order to understand the details of the CPU's functions
Read the H8/300H Series Software Manual.
- In order to understand the details of a register when its name is known
Read the index that is the final part of the manual to find the page number of the entry on the register. The addresses, bits, and initial values of the registers are summarized in section 19, List of Registers.

Example: **Register name:** The following notation is used for cases when the same or a similar function, e.g. serial communication interface, is implemented on more than one channel:

XXX_N (XXX is the register name and N is the channel number)

Bit order: The MSB is on the left and the LSB is on the right.

Notes:

When using an on-chip emulator (E7, E8) for H8/36912, H8/36902 program development and debugging, the following restrictions must be noted.

1. The $\overline{\text{NMI}}$ pin is reserved for the E7 or E8, and cannot be used.
2. Area H'2000 to H'2FFF is used by the E7 or E8, and is not available to the user.
3. Area H'F980 to H'FD7F must on no account be accessed.
4. When the E7 or E8 is used, address breaks can be set as either available to the user or for use by the E7 or E8. If address breaks are set as being used by the E7 or E8, the address break control registers must not be accessed.
5. When the E7 or E8 is used, $\overline{\text{NMI}}$ is an input/output pin (open-drain in output mode).

Related Manuals: The latest versions of all related manuals are available from our web site. Please ensure you have the latest versions of all documents you require.
<http://www.renesas.com/>

H8/36912 Group and H8/36902 Group manuals:

Document Title	Document No.
H8/36912 Group, H8/36902 Group Hardware Manual	This manual
H8/300H Series Software Manual	REJ09B0213

User's manuals for development tools:

Document Title	Document No.
H8S, H8/300 Series C/C++ Compiler, Assembler, Optimizing Linkage Editor User's Manual	REJ10B0058
H8S, H8/300 Series Simulator/Debugger User's Manual	REJ10B0211
H8S, H8/300 Series High-Performance Embedded Workshop 3 Tutorial	REJ10B0024
H8S, H8/300 Series High-Performance Embedded Workshop 3 User's Manual	REJ10B0026

Application notes:

Document Title	Document No.
H8S, H8/300 Series C/C++ Compiler Package Application Note	REJ05B0464
Single Power Supply F-ZTAT™ On-Board Programming	REJ05B0520

Contents

Section 1	Overview	1
1.1	Features	1
1.2	Internal Block Diagram	3
1.3	Pin Arrangement	5
1.4	Pin Functions	9
Section 2	CPU	11
2.1	Address Space and Memory Map	12
2.2	Register Configuration	14
2.2.1	General Registers	15
2.2.2	Program Counter (PC)	16
2.2.3	Condition-Code Register (CCR)	16
2.3	Data Formats	18
2.3.1	General Register Data Formats	18
2.3.2	Memory Data Formats	20
2.4	Instruction Set	21
2.4.1	Table of Instructions Classified by Function	21
2.4.2	Basic Instruction Formats	30
2.5	Addressing Modes and Effective Address Calculation	32
2.5.1	Addressing Modes	32
2.5.2	Effective Address Calculation	35
2.6	Basic Bus Cycle	37
2.6.1	Access to On-Chip Memory (RAM, ROM)	37
2.6.2	On-Chip Peripheral Modules	38
2.7	CPU States	39
2.8	Usage Notes	40
2.8.1	Notes on Data Access to Empty Areas	40
2.8.2	EEPMOV Instruction	40
2.8.3	Bit Manipulation Instruction	40
Section 3	Exception Handling	47
3.1	Exception Sources and Vector Address	47
3.2	Register Descriptions	49
3.2.1	Interrupt Edge Select Register 1 (IEGR1)	49
3.2.2	Interrupt Edge Select Register 2 (IEGR2)	50
3.2.3	Interrupt Enable Register 1 (IENR1)	50

3.2.4	Interrupt Enable Register 2 (IENR2)	51
3.2.5	Interrupt Flag Register 1 (IRR1).....	52
3.2.6	Interrupt Flag Register 2 (IRR2).....	53
3.2.7	Wakeup Interrupt Flag Register (IWPR)	53
3.3	Reset Exception Handling	54
3.4	Interrupt Exception Handling	55
3.4.1	External Interrupts	55
3.4.2	Internal Interrupts	56
3.4.3	Interrupt Handling Sequence	57
3.4.4	Interrupt Response Time.....	59
3.5	Usage Notes	61
3.5.1	Interrupts after Reset.....	61
3.5.2	Notes on Stack Area Use	61
3.5.3	Notes on Rewriting Port Mode Registers	61
Section 4 Address Break		63
4.1	Register Descriptions.....	64
4.1.1	Address Break Control Register (ABRKCR)	64
4.1.2	Address Break Status Register (ABRKSR)	66
4.1.3	Break Address Registers (BARH, BARL).....	66
4.1.4	Break Data Registers (BDRH, BDRL)	66
4.2	Operation	67
Section 5 Clock Pulse Generators		69
5.1	Features.....	70
5.2	Register Descriptions.....	71
5.2.1	RC Control Register (RCCR)	71
5.2.2	RC Trimming Data Protect Register (RCTRMDPR).....	72
5.2.3	RC Trimming Data Register (RCTRMDR)	73
5.2.4	Clock Control/Status Register (CKCSR).....	74
5.3	System Clock Select Operation	75
5.3.1	Clock Control Operation.....	76
5.3.2	Clock Change Timing.....	78
5.4	Trimming of On-chip Oscillator Frequency	80
5.5	External Oscillators	82
5.5.1	Connecting Crystal Resonator	82
5.5.2	Connecting Ceramic Resonator	83
5.5.3	External Clock Input Method.....	83
5.6	Prescaler.....	83
5.6.1	Prescaler S	83

5.7	Usage Notes	84
5.7.1	Note on Resonators	84
5.7.2	Notes on Board Design	84
Section 6 Power-Down Modes		85
6.1	Register Descriptions	85
6.1.1	System Control Register 1 (SYSCR1)	86
6.1.2	System Control Register 2 (SYSCR2)	88
6.1.3	Module Standby Control Register 1 (MSTCR1)	89
6.1.4	Module Standby Control Register 2 (MSTCR2)	90
6.2	Mode Transitions and States of LSI	91
6.2.1	Sleep Mode	93
6.2.2	Standby Mode	93
6.2.3	Subsleep Mode	94
6.3	Operating Frequency in Active Mode	94
6.4	Direct Transition	94
6.5	Module Standby Function	95
Section 7 ROM		97
7.1	Block Configuration	97
7.2	Register Descriptions	99
7.2.1	Flash Memory Control Register 1 (FLMCR1)	99
7.2.2	Flash Memory Control Register 2 (FLMCR2)	100
7.2.3	Erase Block Register 1 (EBR1)	101
7.2.4	Flash Memory Enable Register (FENR)	101
7.3	On-Board Programming Modes	102
7.3.1	Boot Mode	102
7.3.2	Programming/Erasing in User Program Mode	106
7.4	Flash Memory Programming/Erasing	107
7.4.1	Program/Program-Verify	107
7.4.2	Erase/Erase-Verify	109
7.4.3	Interrupt Handling when Programming/Erasing Flash Memory	110
7.5	Program/Erase Protection	112
7.5.1	Hardware Protection	112
7.5.2	Software Protection	112
7.5.3	Error Protection	112
Section 8 RAM		115

Section 9	I/O Ports.....	117
9.1	Port 1.....	117
9.1.1	Port Mode Register 1 (PMR1).....	118
9.1.2	Port Control Register 1 (PCR1).....	119
9.1.3	Port Data Register 1 (PDR1).....	119
9.1.4	Port Pull-Up Control Register 1 (PUCR1).....	120
9.1.5	Pin Functions.....	120
9.2	Port 2.....	121
9.2.1	Port Control Register 2 (PCR2).....	122
9.2.2	Port Data Register 2 (PDR2).....	122
9.2.3	Pin Functions.....	123
9.3	Port 5.....	124
9.3.1	Port Mode Register 5 (PMR5).....	125
9.3.2	Port Control Register 5 (PCR5).....	125
9.3.3	Port Data Register 5 (PDR5).....	126
9.3.4	Port Pull-Up Control Register 5 (PUCR5).....	126
9.3.5	Pin Functions.....	127
9.4	Port 7.....	128
9.4.1	Port Control Register 7 (PCR7).....	128
9.4.2	Port Data Register 7 (PDR7).....	129
9.4.3	Pin Functions.....	129
9.5	Port 8.....	130
9.5.1	Port Control Register 8 (PCR8).....	131
9.5.2	Port Data Register 8 (PDR8).....	131
9.5.3	Pin Functions.....	132
9.6	Port B.....	134
9.6.1	Port Data Register B (PDRB).....	134
9.6.2	Pin Functions.....	135
9.7	Port C.....	136
9.7.1	Port Control Register C (PCRC).....	137
9.7.2	Port Data Register C (PDRC).....	137
9.7.3	Pin Functions.....	138
Section 10	Timer B1.....	139
10.1	Features.....	139
10.2	Register Descriptions.....	140
10.2.1	Timer Mode Register B1 (TMB1).....	140
10.2.2	Timer Counter B1 (TCB1).....	141
10.2.3	Timer Load Register B1 (TLB1).....	141

10.3	Operation	142
10.3.1	Interval Timer Operation	142
10.3.2	Auto-Reload Timer Operation	142
10.4	Timer B1 Operating Modes	143
Section 11 Timer V		145
11.1	Features	145
11.2	Input/Output Pins	147
11.3	Register Descriptions	147
11.3.1	Timer Counter V (TCNTV)	147
11.3.2	Time Constant Registers A and B (TCORA, TCORB)	148
11.3.3	Timer Control Register V0 (TCRV0)	148
11.3.4	Timer Control/Status Register V (TCSRV)	150
11.3.5	Timer Control Register V1 (TCRV1)	151
11.4	Operation	152
11.4.1	Timer V Operation	152
11.5	Timer V Application Examples	155
11.5.1	Pulse Output with Arbitrary Duty Cycle	155
11.5.2	Pulse Output with Arbitrary Pulse Width and Delay from TRGV Input	156
11.6	Usage Notes	157
Section 12 Timer W		159
12.1	Features	159
12.2	Input/Output Pins	162
12.3	Register Descriptions	162
12.3.1	Timer Mode Register W (TMRW)	163
12.3.2	Timer Control Register W (TCRW)	164
12.3.3	Timer Interrupt Enable Register W (TIERW)	165
12.3.4	Timer Status Register W (TSRW)	166
12.3.5	Timer I/O Control Register 0 (TIOR0)	168
12.3.6	Timer I/O Control Register 1 (TIOR1)	169
12.3.7	Timer Counter (TCNT)	171
12.3.8	General Registers A to D (GRA to GRD)	171
12.4	Operation	172
12.4.1	Normal Operation	172
12.4.2	PWM Operation	176
12.5	Operation Timing	181
12.5.1	TCNT Count Timing	181
12.5.2	Output Compare Output Timing	182
12.5.3	Input Capture Timing	183

12.5.4	Timing of Counter Clearing by Compare Match	183
12.5.5	Buffer Operation Timing	184
12.5.6	Timing of IMFA to IMFD Flag Setting at Compare Match	185
12.5.7	Timing of IMFA to IMFD Setting at Input Capture	186
12.5.8	Timing of Status Flag Clearing	186
12.6	Usage Notes	187
Section 13 Watchdog Timer		191
13.1	Features	191
13.2	Register Descriptions	192
13.2.1	Timer Control/Status Register WD (TCSRWD)	192
13.2.2	Timer Counter WD (TCWD)	194
13.2.3	Timer Mode Register WD (TMWD)	194
13.3	Operation	195
Section 14 Serial Communication Interface 3 (SCI3)		197
14.1	Features	197
14.2	Input/Output Pins	199
14.3	Register Descriptions	199
14.3.1	Receive Shift Register (RSR)	200
14.3.2	Receive Data Register (RDR)	200
14.3.3	Transmit Shift Register (TSR)	200
14.3.4	Transmit Data Register (TDR)	200
14.3.5	Serial Mode Register (SMR)	201
14.3.6	Serial Control Register 3 (SCR3)	202
14.3.7	Serial Status Register (SSR)	204
14.3.8	Bit Rate Register (BRR)	206
14.3.9	Sampling Mode Register (SPMR)	211
14.4	Operation in Asynchronous Mode	212
14.4.1	Clock	212
14.4.2	SCI3 Initialization	213
14.4.3	Data Transmission	214
14.4.4	Serial Data Reception	216
14.5	Operation in Clocked Synchronous Mode	219
14.5.1	Clock	219
14.5.2	SCI3 Initialization	220
14.5.3	Serial Data Transmission	220
14.5.4	Serial Data Reception (Clocked Synchronous Mode)	223
14.5.5	Simultaneous Serial Data Transmission and Reception	225
14.6	Multiprocessor Communication Function	227

14.6.1	Multiprocessor Serial Data Transmission	229
14.6.2	Multiprocessor Serial Data Reception	231
14.7	Interrupts	235
14.8	Usage Notes	236
14.8.1	Break Detection and Processing	236
14.8.2	Mark State and Break Sending.....	236
14.8.3	Receive Error Flags and Transmit Operations (Clocked Synchronous Mode Only).....	236
14.8.4	Receive Data Sampling Timing and Reception Margin in Asynchronous Mode	237
Section 15 I ² C Bus Interface 2 (IIC2)		239
15.1	Features	239
15.2	Input/Output Pins	241
15.3	Register Descriptions	242
15.3.1	I ² C Bus Control Register 1 (ICCR1)	242
15.3.2	I ² C Bus Control Register 2 (ICCR2)	245
15.3.3	I ² C Bus Mode Register (ICMR)	246
15.3.4	I ² C Bus Interrupt Enable Register (ICIER)	248
15.3.5	I ² C Bus Status Register (ICSR)	250
15.3.6	Slave Address Register (SAR)	252
15.3.7	I ² C Bus Transmit Data Register (ICDRT)	253
15.3.8	I ² C Bus Receive Data Register (ICDRR)	253
15.3.9	I ² C Bus Shift Register (ICDRS)	253
15.4	Operation	254
15.4.1	I ² C Bus Format	254
15.4.2	Master Transmit Operation	255
15.4.3	Master Receive Operation	257
15.4.4	Slave Transmit Operation	259
15.4.5	Slave Receive Operation	261
15.4.6	Clocked Synchronous Serial Format	263
15.4.7	Noise Canceler	265
15.4.8	Example of Use	266
15.5	Interrupts	270
15.6	Bit Synchronous Circuit	271
15.7	Usage Notes	272
15.7.1	Issue (Retransmission) of Start/Stop Conditions	272
15.7.2	WAIT Setting in I ² C Bus Mode Register (ICMR)	272

Section 16	A/D Converter	273
16.1	Features.....	273
16.2	Input/Output Pins.....	275
16.3	Register Description	275
16.3.1	A/D Data Registers A to D (ADDRA to ADDR D)	275
16.3.2	A/D Control/Status Register (ADCSR)	276
16.3.3	A/D Control Register (ADCR)	278
16.4	Operation	279
16.4.1	Single Mode.....	279
16.4.2	Scan Mode	279
16.4.3	Input Sampling and A/D Conversion Time	280
16.4.4	External Trigger Input Timing.....	281
16.5	A/D Conversion Accuracy Definitions	282
16.6	Usage Notes	284
16.6.1	Permissible Signal Source Impedance	284
16.6.2	Influences on Absolute Accuracy	284
Section 17	Band-Gap Circuit, Power-On Reset, and Low-Voltage Detection Circuits.....	285
17.1	Features.....	286
17.2	Register Descriptions.....	288
17.2.1	Low-Voltage-Detection Control Register (LVDCR).....	288
17.2.2	Low-Voltage-Detection Status Register (LVDSR).....	290
17.3	Operations.....	291
17.3.1	Power-On Reset Circuit.....	291
17.3.2	Low-Voltage Detection Circuit.....	292
Section 18	Power Supply Circuit	299
18.1	When Using Internal Power Supply Step-Down Circuit	299
18.2	When Not Using Internal Power Supply Step-Down Circuit	300
Section 19	List of Registers.....	301
19.1	Register Addresses (Address Order).....	302
19.2	Register Bits	306
19.3	Register States in Each Operating Mode	309
Section 20	Electrical Characteristics	313
20.1	Absolute Maximum Ratings	313
20.2	Electrical Characteristics (F-ZTAT™ Version).....	314

20.2.1	Power Supply Voltage and Operating Ranges	314
20.2.2	DC Characteristics	316
20.2.3	AC Characteristics	321
20.2.4	A/D Converter Characteristics	325
20.2.5	Watchdog Timer Characteristics.....	326
20.2.6	Power-Supply-Voltage Detection Circuit Characteristics.....	327
20.2.7	LVDI External Voltage Detection Circuit Characteristics.....	327
20.2.8	Power-On Reset Characteristics.....	328
20.2.9	Flash Memory Characteristics	329
20.3	Electrical Characteristics (Masked ROM Version).....	331
20.3.1	Power Supply Voltage and Operating Ranges	331
20.3.2	DC Characteristics	333
20.3.3	AC Characteristics	338
20.3.4	A/D Converter Characteristics	342
20.3.5	Watchdog Timer Characteristics.....	343
20.3.6	Power-Supply-Voltage Detection Circuit Characteristics.....	344
20.3.7	LVDI External Voltage Detection Circuit Characteristics.....	344
20.3.8	Power-On Reset Characteristics.....	345
20.4	Operation Timing.....	346
20.5	Output Load Condition	348
Appendix A Instruction Set		349
A.1	Instruction List.....	349
A.2	Operation Code Map.....	364
A.3	Number of Execution States	367
A.4	Combinations of Instructions and Addressing Modes	378
Appendix B I/O Port Block Diagrams		379
B.1	I/O Port Block Diagrams	379
B.2	Port States in Each Operating State	394
Appendix C Product Code Lineup.....		395
Appendix D Package Dimensions		396
Main Revisions and Additions in this Edition		399
Index		405

Figures

Section 1 Overview

Figure 1.1	Internal Block Diagram of H8/36912 Group.....	3
Figure 1.2	Internal Block Diagram of H8/36902 Group.....	4
Figure 1.3	Pin Arrangement of H8/36912 Group (FP-32A).....	5
Figure 1.4	Pin Arrangement of H8/36902 Group (FP-32A).....	6
Figure 1.5	Pin Arrangement of H8/36912 Group (FP-32D, 32P4B).....	7
Figure 1.6	Pin Arrangement of H8/36902 Group (FP-32D, 32P4B).....	8

Section 2 CPU

Figure 2.1	Memory Map (1).....	12
Figure 2.1	Memory Map (2).....	13
Figure 2.2	CPU Registers.....	14
Figure 2.3	Usage of General Registers.....	15
Figure 2.4	Relationship between Stack Pointer and Stack Area.....	16
Figure 2.5	General Register Data Formats (1).....	18
Figure 2.5	General Register Data Formats (2).....	19
Figure 2.6	Memory Data Formats.....	20
Figure 2.7	Instruction Formats.....	31
Figure 2.8	Branch Address Specification in Memory Indirect Mode.....	35
Figure 2.9	On-Chip Memory Access Cycle.....	37
Figure 2.10	On-Chip Peripheral Module Access Cycle (3-State Access).....	38
Figure 2.11	CPU Operation States.....	39
Figure 2.12	State Transitions.....	40
Figure 2.13	Example of Timer Configuration with Two Registers Allocated to Same Address.....	41

Section 3 Exception Handling

Figure 3.1	Reset Sequence.....	56
Figure 3.2	Stack Status after Exception Handling.....	58
Figure 3.3	Interrupt Sequence.....	60
Figure 3.4	Port Mode Register Setting and Interrupt Request Flag Clearing Procedure.....	61

Section 4 Address Break

Figure 4.1	Block Diagram of Address Break.....	63
Figure 4.2	Address Break Interrupt Operation Example (1).....	67
Figure 4.2	Address Break Interrupt Operation Example (2).....	68

Section 5 Clock Pulse Generators

Figure 5.1	Block Diagram of Clock Pulse Generators.....	69
Figure 5.2	State Transition of System Clock.....	75
Figure 5.3	Flowchart of Clock Switching On-chip Oscillator Clock to External Clock (1).....	76
Figure 5.4	Flowchart of Clock Switching External Clock to On-chip Oscillator Clock (2).....	77
Figure 5.5	Timing Chart of Switching On-chip Oscillator Clock to External Clock.....	78
Figure 5.6	Timing Chart to Switch External Clock to On-chip Oscillator Clock.....	79
Figure 5.7	Example of Trimming Flow for On-chip Oscillator Frequency.....	80
Figure 5.8	Timing Chart of Trimming of On-chip Oscillator Frequency.....	81
Figure 5.9	Example of Connection to Crystal Resonator.....	82
Figure 5.10	Equivalent Circuit of Crystal Resonator.....	82
Figure 5.11	Example of Connection to Ceramic Resonator.....	83
Figure 5.12	Example of External Clock Input.....	83
Figure 5.13	Example of Incorrect Board Design.....	84

Section 6 Power-Down Modes

Figure 6.1	Mode Transition Diagram.....	91
------------	------------------------------	----

Section 7 ROM

Figure 7.1	Flash Memory Block Configuration.....	98
Figure 7.2	Programming/Erasing Flowchart Example in User Program Mode.....	106
Figure 7.3	Program/Program-Verify Flowchart.....	108
Figure 7.4	Erase/Erase-Verify Flowchart.....	111

Section 9 I/O Ports

Figure 9.1	Port 1 Pin Configuration.....	117
Figure 9.2	Port 2 Pin Configuration.....	121
Figure 9.3	Port 5 Pin Configuration.....	124
Figure 9.4	Port 7 Pin Configuration.....	128
Figure 9.5	Port 8 Pin Configuration.....	130
Figure 9.6	Port B Pin Configuration.....	134
Figure 9.7	Port C Pin Configuration.....	136

Section 10 Timer B1

Figure 10.1	Block Diagram of Timer B1.....	139
-------------	--------------------------------	-----

Section 11 Timer V

Figure 11.1	Block Diagram of Timer V.....	146
Figure 11.2	Increment Timing with Internal Clock.....	153
Figure 11.3	Increment Timing with External Clock.....	153
Figure 11.4	OVF Set Timing.....	153
Figure 11.5	CMFA and CMFB Set Timing.....	154

Figure 11.6	TMOV Output Timing	154
Figure 11.7	Clear Timing by Compare Match.....	154
Figure 11.8	Clear Timing by TMRIV Input	155
Figure 11.9	Pulse Output Example	155
Figure 11.10	Example of Pulse Output Synchronized to TRGV Input.....	156
Figure 11.11	Contention between TCNTV Write and Clear	157
Figure 11.12	Contention between TCORA Write and Compare Match	158
Figure 11.13	Internal Clock Switching and TCNTV Operation	158

Section 12 Timer W

Figure 12.1	Timer W Block Diagram	161
Figure 12.2	Free-Running Counter Operation	172
Figure 12.3	Periodic Counter Operation.....	173
Figure 12.4	0 and 1 Output Example (TOA = 0, TOB = 1).....	173
Figure 12.5	Toggle Output Example (TOA = 0, TOB = 1)	174
Figure 12.6	Toggle Output Example (TOA = 0, TOB = 1)	174
Figure 12.7	Input Capture Operating Example.....	175
Figure 12.8	Buffer Operation Example (Input Capture).....	176
Figure 12.9	PWM Mode Example (1)	177
Figure 12.10	PWM Mode Example (2)	177
Figure 12.11	Buffer Operation Example (Output Compare)	178
Figure 12.12	PWM Mode Example (TOB, TOC, and TOD = 0: Initial Output Values are Set to 0).....	179
Figure 12.13	PWM Mode Example (TOB, TOC, and TOD = 1: Initial Output Values are Set to 1).....	180
Figure 12.14	Count Timing for Internal Clock Source.....	181
Figure 12.15	Count Timing for External Clock Source.....	181
Figure 12.16	Output Compare Output Timing	182
Figure 12.17	Input Capture Input Signal Timing.....	183
Figure 12.18	Timing of Counter Clearing by Compare Match.....	183
Figure 12.19	Buffer Operation Timing (Compare Match).....	184
Figure 12.20	Buffer Operation Timing (Input Capture)	184
Figure 12.21	Timing of IMFA to IMFD Flag Setting at Compare Match	185
Figure 12.22	Timing of IMFA to IMFD Flag Setting at Input Capture.....	186
Figure 12.23	Timing of Status Flag Clearing by CPU.....	186
Figure 12.24	Contention between TCNT Write and Clear	188
Figure 12.25	Internal Clock Switching and TCNT Operation.....	188
Figure 12.26	When Compare Match and Bit Manipulation Instruction to TCRW Occur at the Same Timing	189

Section 13 Watchdog Timer

Figure 13.1	Block Diagram of Watchdog Timer	191
Figure 13.2	Watchdog Timer Operation Example	195

Section 14 Serial Communication Interface 3 (SCI3)

Figure 14.1	Block Diagram of SCI3	198
Figure 14.2	Block Diagram of Noise Filter Circuit	211
Figure 14.3	Data Format in Asynchronous Communication	212
Figure 14.4	Relationship between Output Clock and Transfer Data Phase (Asynchronous Mode) (Example with 8-Bit Data, Parity, Two Stop Bits)	212
Figure 14.5	Sample SCI3 Initialization Flowchart	213
Figure 14.6	Example of SCI3 Transmission in Asynchronous Mode (8-Bit Data, Parity, One Stop Bit)	214
Figure 14.7	Sample Serial Transmission Data Flowchart (Asynchronous Mode)	215
Figure 14.8	Example of SCI3 Reception in Asynchronous Mode (8-Bit Data, Parity, One Stop Bit)	216
Figure 14.9	Sample Serial Reception Data Flowchart (Asynchronous Mode)	218
Figure 14.10	Data Format in Clocked Synchronous Communication	219
Figure 14.11	Example of SCI3 Transmission in Clocked Synchronous Mode	221
Figure 14.12	Sample Serial Transmission Flowchart (Clocked Synchronous Mode)	222
Figure 14.13	Example of SCI3 Reception in Clocked Synchronous Mode	223
Figure 14.14	Sample Serial Reception Flowchart (Clocked Synchronous Mode)	224
Figure 14.15	Sample Flowchart of Simultaneous Serial Transmit and Receive Operations (Clocked Synchronous Mode)	226
Figure 14.16	Example of Inter-Processor Communication Using Multiprocessor Format (Transmission of Data H'AA to Receiving Station A)	228
Figure 14.17	Sample Multiprocessor Serial Transmission Flowchart	230
Figure 14.18	Sample Multiprocessor Serial Reception Flowchart (1)	232
Figure 14.18	Sample Multiprocessor Serial Reception Flowchart (2)	233
Figure 14.19	Example of SCI3 Reception Using Multiprocessor Format (Example with 8-Bit Data, Multiprocessor Bit, One Stop Bit)	234
Figure 14.20	Receive Data Sampling Timing in Asynchronous Mode	237

Section 15 I²C Bus Interface 2 (IIC2)

Figure 15.1	Block Diagram of I ² C Bus Interface 2	240
Figure 15.2	External Circuit Connections of I/O Pins	241
Figure 15.3	I ² C Bus Formats	254
Figure 15.4	I ² C Bus Timing	254
Figure 15.5	Master Transmit Mode Operation Timing (1)	256
Figure 15.6	Master Transmit Mode Operation Timing (2)	256
Figure 15.7	Master Receive Mode Operation Timing (1)	258

Figure 15.8	Master Receive Mode Operation Timing (2).....	259
Figure 15.9	Slave Transmit Mode Operation Timing (1).....	260
Figure 15.10	Slave Transmit Mode Operation Timing (2).....	261
Figure 15.11	Slave Receive Mode Operation Timing (1).....	262
Figure 15.12	Slave Receive Mode Operation Timing (2).....	262
Figure 15.13	Clocked Synchronous Serial Transfer Format.....	263
Figure 15.14	Transmit Mode Operation Timing.....	264
Figure 15.15	Receive Mode Operation Timing.....	265
Figure 15.16	Block Diagram of Noise Canceler.....	265
Figure 15.17	Sample Flowchart for Master Transmit Mode.....	266
Figure 15.18	Sample Flowchart for Master Receive Mode.....	267
Figure 15.19	Sample Flowchart for Slave Transmit Mode.....	268
Figure 15.20	Sample Flowchart for Slave Receive Mode.....	269
Figure 15.21	Timing of Bit Synchronous Circuit.....	271
 Section 16 A/D Converter		
Figure 16.1	Block Diagram of A/D Converter.....	274
Figure 16.2	A/D Conversion Timing.....	280
Figure 16.3	External Trigger Input Timing.....	281
Figure 16.4	A/D Conversion Accuracy Definitions (1).....	283
Figure 16.5	A/D Conversion Accuracy Definitions (2).....	283
Figure 16.6	Analog Input Circuit Example.....	284
 Section 17 Band-Gap Circuit, Power-On Reset, and Low-Voltage Detection Circuits		
Figure 17.1	Block Diagram around BGR.....	286
Figure 17.2	Block Diagram of Power-On Reset Circuit and Low-Voltage Detection Circuit....	287
Figure 17.3	Operational Timing of Power-On Reset Circuit.....	292
Figure 17.4	Operating Timing of LVDR Circuit.....	293
Figure 17.5	Operational Timing of LVDI Circuit.....	294
Figure 17.6	Operational Timing of LVDI Circuit (When Compared Voltage is Input through ExtU and ExtD Pins).....	296
Figure 17.7	Timing for Enabling/Disabling of Low-Voltage Detection Circuit.....	297
 Section 18 Power Supply Circuit		
Figure 18.1	Power Supply Connection when Internal Step-Down Circuit is Used.....	299
Figure 18.2	Power Supply Connection when Internal Step-Down Circuit is Not Used.....	300
 Section 20 Electrical Characteristics		
Figure 20.1	System Clock Input Timing.....	346
Figure 20.2	RES Low Width Timing.....	346
Figure 20.3	Input Timing.....	346
Figure 20.4	I ² C Bus Interface Input/Output Timing.....	347

Figure 20.5	SCK3 Input Clock Timing	347
Figure 20.6	SCI3 Input/Output Timing in Clocked Synchronous Mode	348
Figure 20.7	Output Load Circuit	348

Appendix

Figure B.1	Port 1 Block Diagram (P17)	379
Figure B.2	Port 1 Block Diagram (P14)	380
Figure B.3	Port 2 Block Diagram (P22)	381
Figure B.4	Port 2 Block Diagram (P21)	382
Figure B.5	Port 2 Block Diagram (P20)	383
Figure B.6 (1)	Port 5 Block Diagram (P57, P56) (for H8/36912 Group)	384
Figure B.6 (2)	Port 5 Block Diagram (P57, P56) (for H8/36902 Group)	385
Figure B.7	Port 5 Block Diagram (P55)	386
Figure B.8	Port 5 Block Diagram (P76)	387
Figure B.9	Port 7 Block Diagram (P75)	388
Figure B.10	Port 7 Block Diagram (P74)	389
Figure B.11	Port 8 Block Diagram (P84 to P81)	390
Figure B.12	Port 8 Block Diagram (P80)	391
Figure B.13	Port B Block Diagram (PB3, PB2)	392
Figure B.14	Port B Block Diagram (PB1, PB0)	392
Figure B.15	Port C Block Diagram (PC1)	393
Figure B.16	Port C Block Diagram (PC0)	394
Figure D.1	FP-32D Package Dimensions	396
Figure D.2	FP-32A Package Dimension	397
Figure D.3	32P4B Package Dimension	398

Tables

Section 1 Overview

Table 1.1	Pin Functions	9
-----------	---------------------	---

Section 2 CPU

Table 2.1	Operation Notation	21
Table 2.2	Data Transfer Instructions.....	22
Table 2.3	Arithmetic Operations Instructions (1)	23
Table 2.3	Arithmetic Operations Instructions (2)	24
Table 2.4	Logic Operations Instructions.....	25
Table 2.5	Shift Instructions.....	25
Table 2.6	Bit Manipulation Instructions (1).....	26
Table 2.6	Bit Manipulation Instructions (2).....	27
Table 2.7	Branch Instructions	28
Table 2.8	System Control Instructions.....	29
Table 2.9	Block Data Transfer Instructions	30
Table 2.10	Addressing Modes	32
Table 2.11	Absolute Address Access Ranges.....	34
Table 2.12	Effective Address Calculation (1).....	35
Table 2.12	Effective Address Calculation (2).....	36

Section 3 Exception Handling

Table 3.1	Exception Sources and Vector Address	47
Table 3.2	Interrupt Wait States	59

Section 4 Address Break

Table 4.1	Access and Data Bus Used	65
-----------	--------------------------------	----

Section 5 Clock Pulse Generators

Table 5.1	Crystal Resonator Parameters	82
-----------	------------------------------------	----

Section 6 Power-Down Modes

Table 6.1	Operating Frequency and Wait Time.....	87
Table 6.2	Transition Mode after SLEEP Instruction Execution and Interrupt Handling	92
Table 6.3	Internal State in Each Operating Mode.....	92

Section 7 ROM

Table 7.1	Setting Programming Modes	102
Table 7.2	Boot Mode Operation	104
Table 7.3	System Clock Frequencies for which Automatic Adjustment of LSI Bit Rate is Possible.....	105

Table 7.4	Reprogram Data Computation Table	109
Table 7.5	Additional-Program Data Computation Table	109
Table 7.6	Programming Time	109
Section 10 Timer B1		
Table 10.1	Timer B1 Operating Modes	143
Section 11 Timer V		
Table 11.1	Pin Configuration.....	147
Table 11.2	Clock Signals to Input to TCNTV and Counting Conditions	149
Section 12 Timer W		
Table 12.1	Timer W Functions	160
Table 12.2	Pin Configuration.....	162
Section 14 Serial Communication Interface 3 (SCI3)		
Table 14.1	Pin Configuration.....	199
Table 14.2	Examples of BRR Settings for Various Bit Rates (Asynchronous Mode).....	207
Table 14.3	Maximum Bit Rate for Each Frequency (Asynchronous Mode)	209
Table 14.4	Examples of BRR Settings for Various Bit Rates (Clocked Synchronous Mode)	210
Table 14.5	SSR Status Flags and Receive Data Handling	217
Table 14.6	SCI3 Interrupt Requests.....	235
Section 15 I²C Bus Interface 2 (IIC2)		
Table 15.1	Pin Configuration.....	241
Table 15.2	Transfer Rate	244
Table 15.3	Interrupt Requests	270
Table 15.4	Time for Monitoring SCL.....	271
Section 16 A/D Converter		
Table 16.1	Pin Configuration.....	275
Table 16.2	Analog Input Channels and Corresponding ADDR Registers	276
Table 16.3	A/D Conversion Time (Single Mode).....	281
Section 17 Band-Gap Circuit, Power-On Reset, and Low-Voltage Detection Circuits		
Table 17.1	LVDCR Settings and Select Functions.....	289
Section 20 Electrical Characteristics		
Table 20.1	Absolute Maximum Ratings	313
Table 20.2	DC Characteristics (1)	316
Table 20.2	DC Characteristics (2)	320
Table 20.3	AC Characteristics	321
Table 20.4	I ² C Bus Interface Timing.....	323

Table 20.5	Serial Interface (SCI3) Timing	324
Table 20.6	A/D Converter Characteristics	325
Table 20.7	Watchdog Timer Characteristics.....	326
Table 20.8	Power-Supply-Voltage Detection Circuit Characteristics.....	327
Table 20.9	LVDI External Voltage Detection Circuit Characteristics.....	327
Table 20.10	Power-On Reset Circuit Characteristics.....	328
Table 20.11	Flash Memory Characteristics	329
Table 20.12	DC Characteristics (1).....	333
Table 20.12	DC Characteristics (2).....	337
Table 20.13	AC Characteristics	338
Table 20.14	I ² C Bus Interface Timing	340
Table 20.15	Serial Interface (SCI3) Timing	341
Table 20.16	A/D Converter Characteristics	342
Table 20.17	Watchdog Timer Characteristics.....	343
Table 20.18	Power-Supply-Voltage Detection Circuit Characteristics.....	344
Table 20.19	LVDI External Voltage Detection Circuit Characteristics.....	344
Table 20.20	Power-On Reset Circuit Characteristics.....	345

Appendix

Table A.1	Instruction Set	351
Table A.2	Operation Code Map (1)	364
Table A.2	Operation Code Map (2)	365
Table A.2	Operation Code Map (3)	366
Table A.3	Number of Cycles in Each Instruction	368
Table A.4	Number of Cycles in Each Instruction	369
Table A.5	Combinations of Instructions and Addressing Modes	378

Section 1 Overview

1.1 Features

- High-speed H8/300H central processing unit with an internal 16-bit architecture
 - Upward-compatible with H8/300 CPU on an object level
 - Sixteen 16-bit general registers
 - 62 basic instructions
- Various peripheral functions
 - Timer B1* (8-bit timer)
 - Timer V (8-bit timer)
 - Timer W (16-bit timer)
 - Watchdog timer
 - SCI3 (Asynchronous or clocked synchronous serial communication interface)
 - 10-bit A/D converter
 - I²C bus interface* (conforms to the Philips I²C bus interface functions)
 - POR/LVD (Power-on reset and low-voltage detection circuits)
 - Address break

Note: * Available for the H8/36912 Group only.

- On-chip memory

Product Classification		Type	ROM	RAM	Remarks
Flash memory version (F-ZTAT™ version)	H8/36912F	HD64F36912G	8 kbytes	1,536 bytes	
	H8/36902F	HD64F36902G	8 kbytes	1,536 bytes	
Masked ROM version	H8/36912	HD64336912G	8 kbytes	512 bytes	
	H8/36911	HD64336911G	4 kbytes	256 bytes	
	H8/36902	HD64336902G	8 kbytes	512 bytes	
	H8/36901	HD64336901G	4 kbytes	256 bytes	
	H8/36900	HD64336900G	2 kbytes	256 bytes	

Note: F-ZTAT™ is a trademark of Renesas Technology Corp.

- General I/O ports
 - Eighteen I/O pins, including five large-current ports ($I_{OL} = 20 \text{ mA}$, @ $V_{OL} = 1.5 \text{ V}$, $-I_{OH} = 4 \text{ mA}$, @ $V_{OH} = V_{CC} - 1.0 \text{ V}$)
 - Four input only pins (also used for analog input)
- On-chip oscillator
 - Frequency accuracy: 8MHz $\pm 1\%$ (Typ.) $V_{CC} = 5.0 \text{ V}$, $T_a = 25^\circ\text{C}$
(Flash memory version): 8MHz $\pm 3\%$ $V_{CC} = 4.0 \text{ to } 5.0 \text{ V}$, $T_a = -20 \text{ to } 75^\circ\text{C}$
10MHz $\pm 4\%$ (Typ.) $V_{CC} = 4.0 \text{ to } 5.0 \text{ V}$, $T_a = -20 \text{ to } 75^\circ\text{C}$
- Supports various power-down modes
- Compact package

Package	Code	Body Size	Pin Pitch	Remarks
LQFP-32	FP-32A	7.0 × 7.0 mm	0.8 mm	
SOP-32	FP-32D	11.3 × 20.45 mm	1.27 mm	
SDIP-32*	32P4B	400 mil	1.78 mm	

Note: * Flash memory version only

1.2 Internal Block Diagram

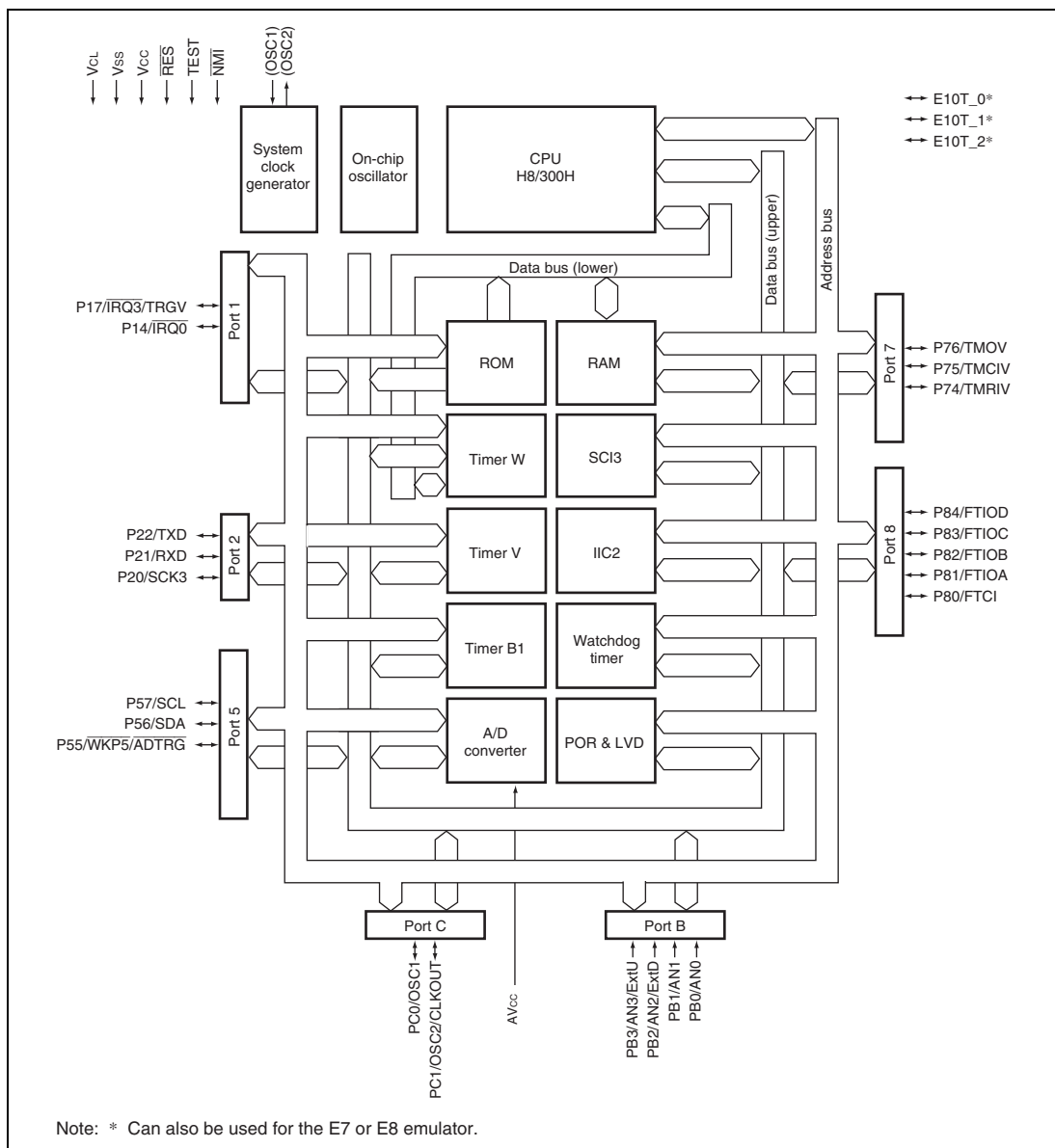

Figure 1.1 Internal Block Diagram of H8/36912 Group

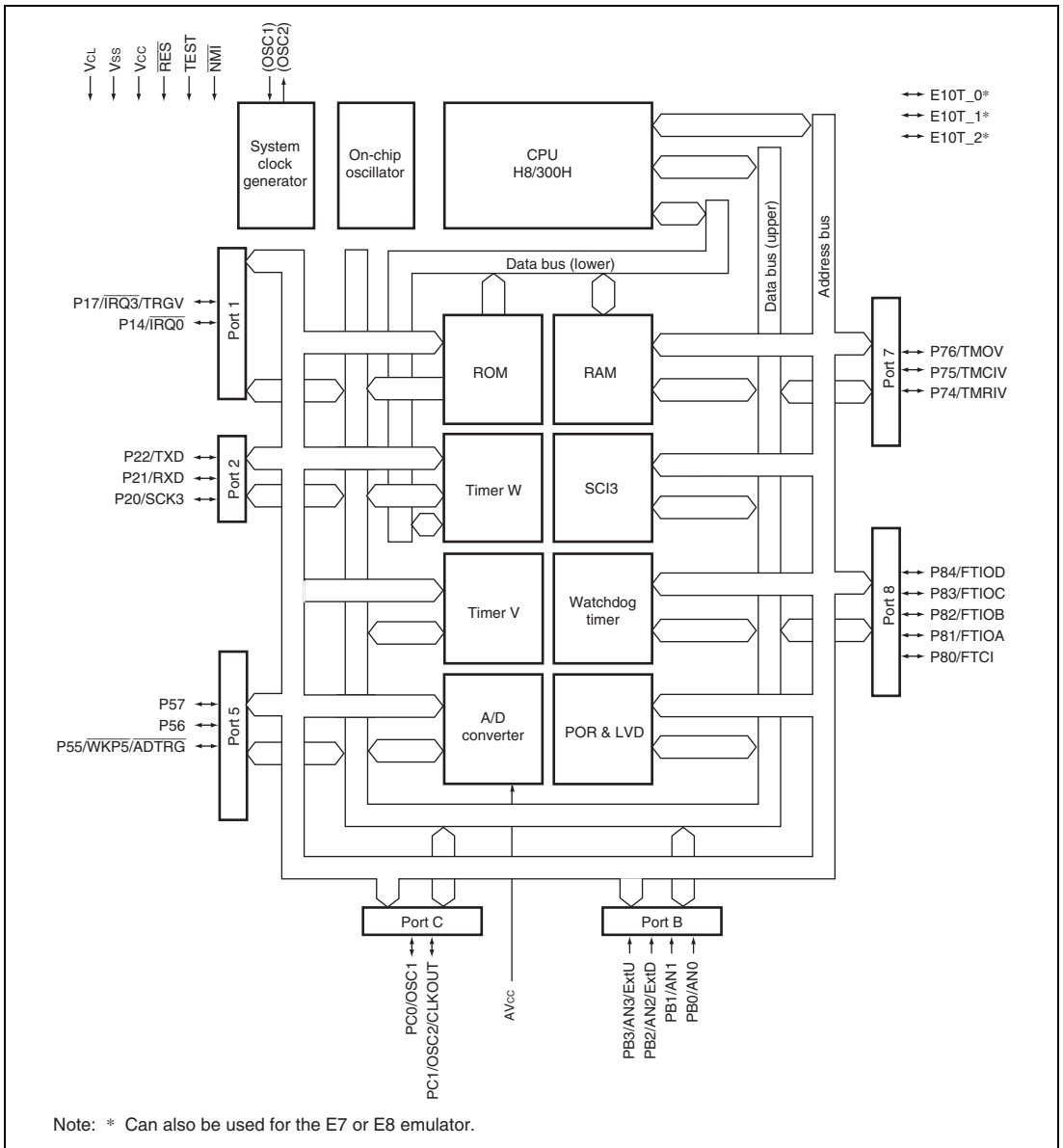

Figure 1.2 Internal Block Diagram of H8/36902 Group

1.3 Pin Arrangement

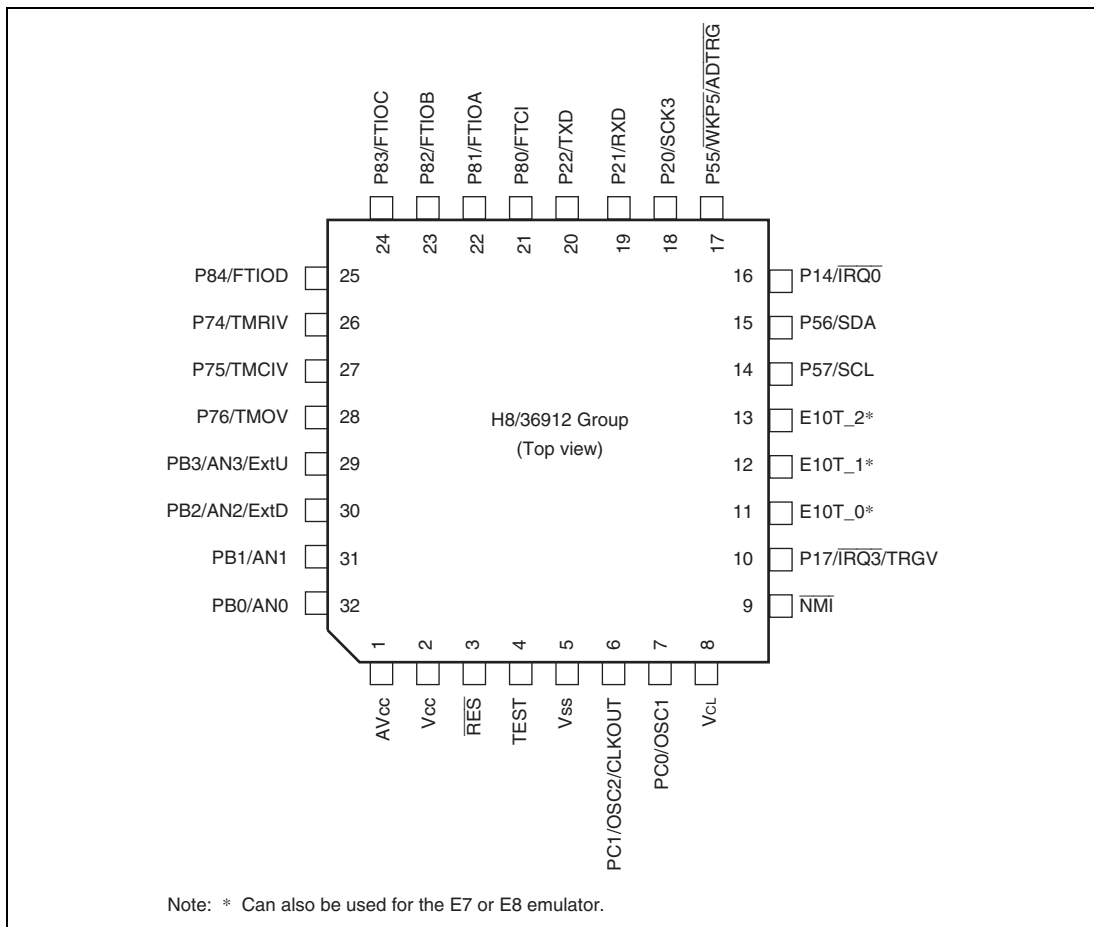
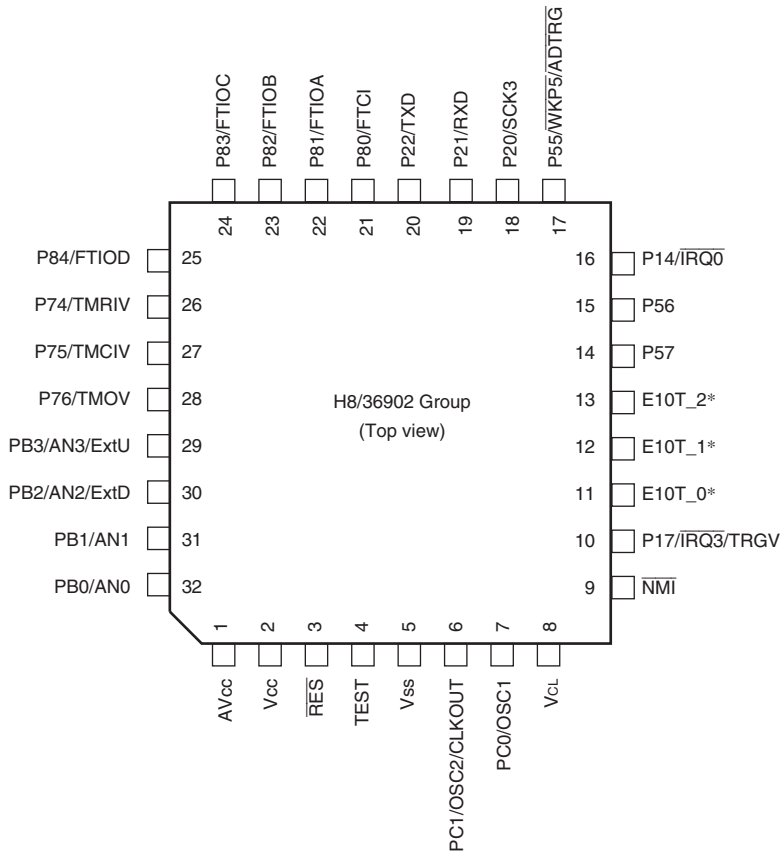
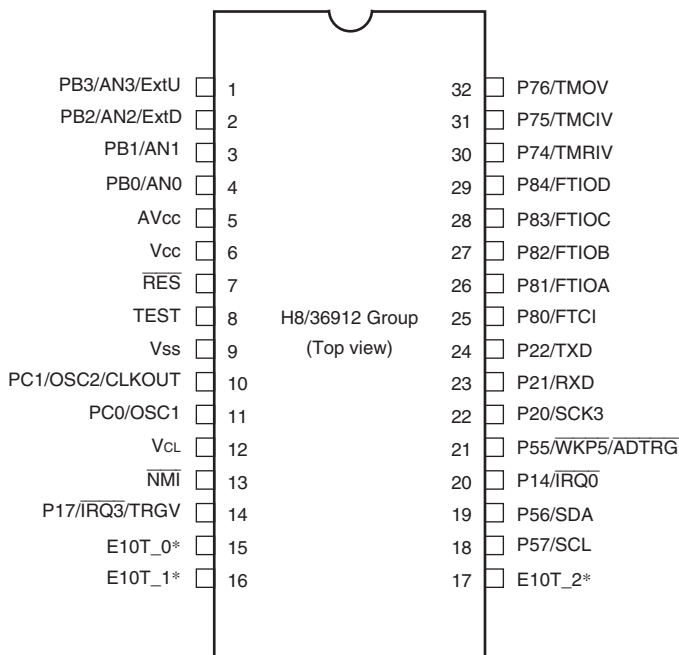

Figure 1.3 Pin Arrangement of H8/36912 Group (FP-32A)



Note: * Can also be used for the E7 or E8 emulator.

Figure 1.4 Pin Arrangement of H8/36902 Group (FP-32A)



Note: * Can also be used for the E7 or E8 emulator.

Figure 1.5 Pin Arrangement of H8/36912 Group (FP-32D, 32P4B)

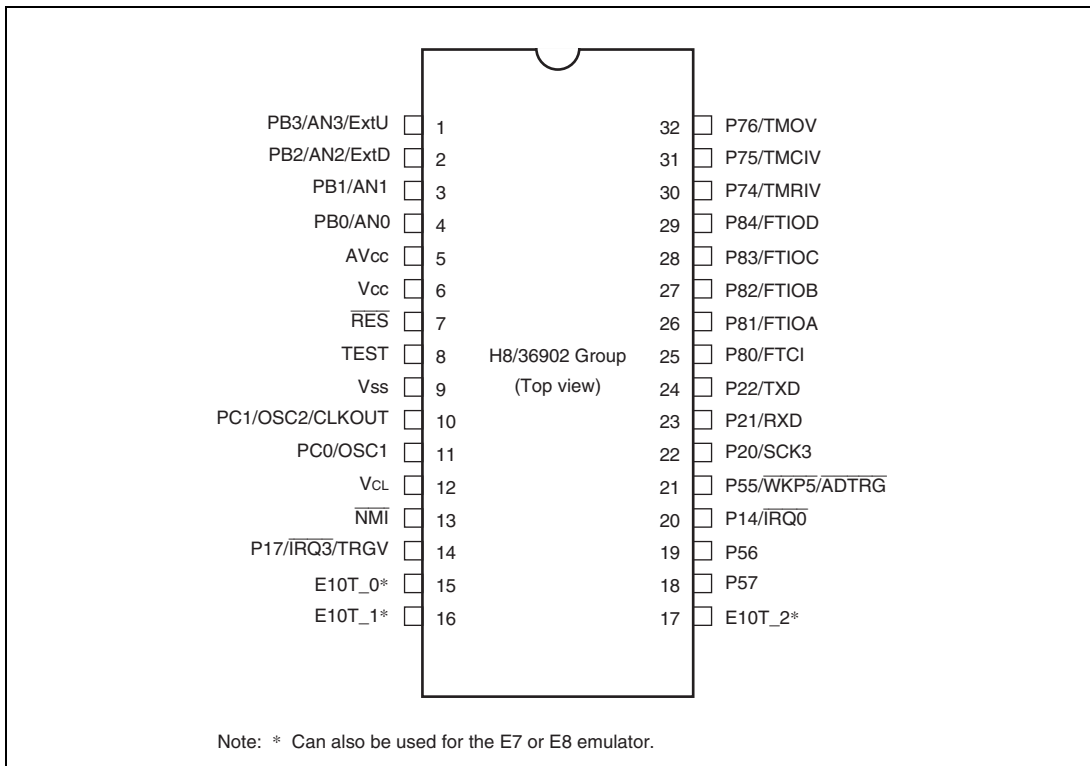

Figure 1.6 Pin Arrangement of H8/36902 Group (FP-32D, 32P4B)

1.4 Pin Functions

Table 1.1 Pin Functions

Type	Symbol	Pin No.		I/O	Functions
		FP-32D, 32P4B	FP-32A		
Power source	V_{CC}	6	2	Input	Power supply pin. Connect this pin to the system power supply.
	V_{SS}	9	5	Input	Ground pin. Connect this pin to the system power supply (0 V).
	AV_{CC}	5	1	Input	Analog power supply pin for the A/D converter. When the A/D converter is not used, connect this pin to the system power supply.
	V_{CL}	12	8	Input	Internal step-down power supply pin. Connect a capacitor of around 0.1 μ F between this pin and the Vss pin for stabilization.
Clock	OSC1	11	7	Input	These pins are connected to a crystal or ceramic resonator for system clocks, or can be used to input an external clock. When an on-chip oscillator is used, system clocks can be output to OSC2. See section 5, Clock Pulse Generators, for a typical connection.
	OSC2/ CLKOUT	10	6	Output	
System control	\overline{RES}	7	3	Input	Reset pin. The pull-up resistor (typ. 150 k Ω) is incorporated. When driven low, the chip is reset.
	TEST	8	4	Input	Test pin. Connect this pin to Vss.
External interrupt	\overline{NMI}	13	9	Input	Non-maskable interrupt request input pin. Be sure to pull-up by a pull-up resistor.
	$\overline{IRQ0}$, $\overline{IRQ3}$	20, 14	16, 10	Input	External interrupt request input pins. Can select the rising or falling edge.
	$\overline{WKP5}$	21	17	Input	External interrupt request input pin. Can select the rising or falling edge.

Type	Symbol	Pin No.		I/O	Functions
		FP-32D, 32P4B	FP-32A		
Timer V	TMOV	32	28	Output	TMOV is an output pin for waveforms generated by the output compare function.
	TMCIV	31	27	Input	External event input pin
	TMRIV	30	26	Input	Counter reset input pin
	TRGV	14	10	Input	Counter start trigger input pin
Timer W	FTCI	25	21	Input	External event input pin
	FTIOA to FTIOD	26 to 29	22 to 25	I/O	Output compare output/ input capture input/ PWM output common pins
I ² C bus interface 2*	SDA	19	15	I/O	I ² C data I/O pin. NMOS open drain output can directly drive the bus.
	SCL	18	14	I/O	I ² C clock I/O pin. NMOS open drain output can directly drive the bus.
Serial communication interface	TXD	24	20	Output	Transmit data output pin
	RXD	23	19	Input	Receive data input pin
	SCK3	22	18	I/O	Clock I/O pin
A/D converter	AN3 to AN0	1 to 4	29 to 32	Input	Analog input pin
	ADTRG	21	17	Input	A/D converter trigger input pin
I/O ports	P17, P14	14, 20	10, 16	I/O	2-bit I/O port
	P22 to P20	24 to 22	20 to 18	I/O	3-bit I/O port
	P57 to P55	18, 19, 21	14, 15, 17	I/O	3-bit I/O port
	P76 to P74	32 to 30	28 to 26	I/O	3-bit I/O port
	P84 to P80	29 to 25	25 to 21	I/O	5-bit I/O port
	PB3 to PB0	1 to 4	29 to 32	Input	4-bit input port
	PC1, PC0	10, 11	6, 7	I/O	2-bit I/O port
Low voltage detection circuit	ExtU, ExtD	1, 2	29, 30	Input	External input pins for the detection voltage used in the low-voltage detection circuit
E7, E8	E10T_0, E10T_1, E10T_2	15, 16, 17	11, 12, 13	—	Interface pins for the E7 or E8 emulator

Note: * Available for the H8/36912 Group only.

Section 2 CPU

This LSI has an H8/300H CPU with an internal 32-bit architecture that is upward-compatible with the H8/300 CPU, and supports only normal mode, which has a 64-kbyte address space.

- Upward-compatible with H8/300 CPUs
 - Can execute H8/300 CPUs object programs
 - Additional eight 16-bit extended registers
 - 32-bit transfer and arithmetic and logic instructions are added
 - Signed multiply and divide instructions are added.
- General-register architecture
 - Sixteen 16-bit general registers also usable as sixteen 8-bit registers or eight 32-bit registers
- Sixty-two basic instructions
 - 8/16/32-bit data transfer and arithmetic and logic instructions
 - Multiply and divide instructions
 - Powerful bit-manipulation instructions
- Eight addressing modes
 - Register direct [Rn]
 - Register indirect [@ERn]
 - Register indirect with displacement [@(d:16,ERn) or @(d:24,ERn)]
 - Register indirect with post-increment or pre-decrement [@ERn+ or @-ERn]
 - Absolute address [@aa:8, @aa:16, @aa:24]
 - Immediate [#xx:8, #xx:16, or #xx:32]
 - Program-counter relative [@(d:8,PC) or @(d:16,PC)]
 - Memory indirect [@@aa:8]
- 64-kbyte address space
- High-speed operation
 - All frequently-used instructions execute in two or four states
 - 8/16/32-bit register-register add/subtract : 2 state
 - 8×8 -bit register-register multiply : 14 states
 - $16 \div 8$ -bit register-register divide : 14 states
 - 16×16 -bit register-register multiply : 22 states
 - $32 \div 16$ -bit register-register divide : 22 states
- Power-down state
 - Transition to power-down state by SLEEP instruction

2.1 Address Space and Memory Map

The address space of this LSI is 64 kbytes, which includes the program area and the data area. The following two figures show the memory map, respectively.

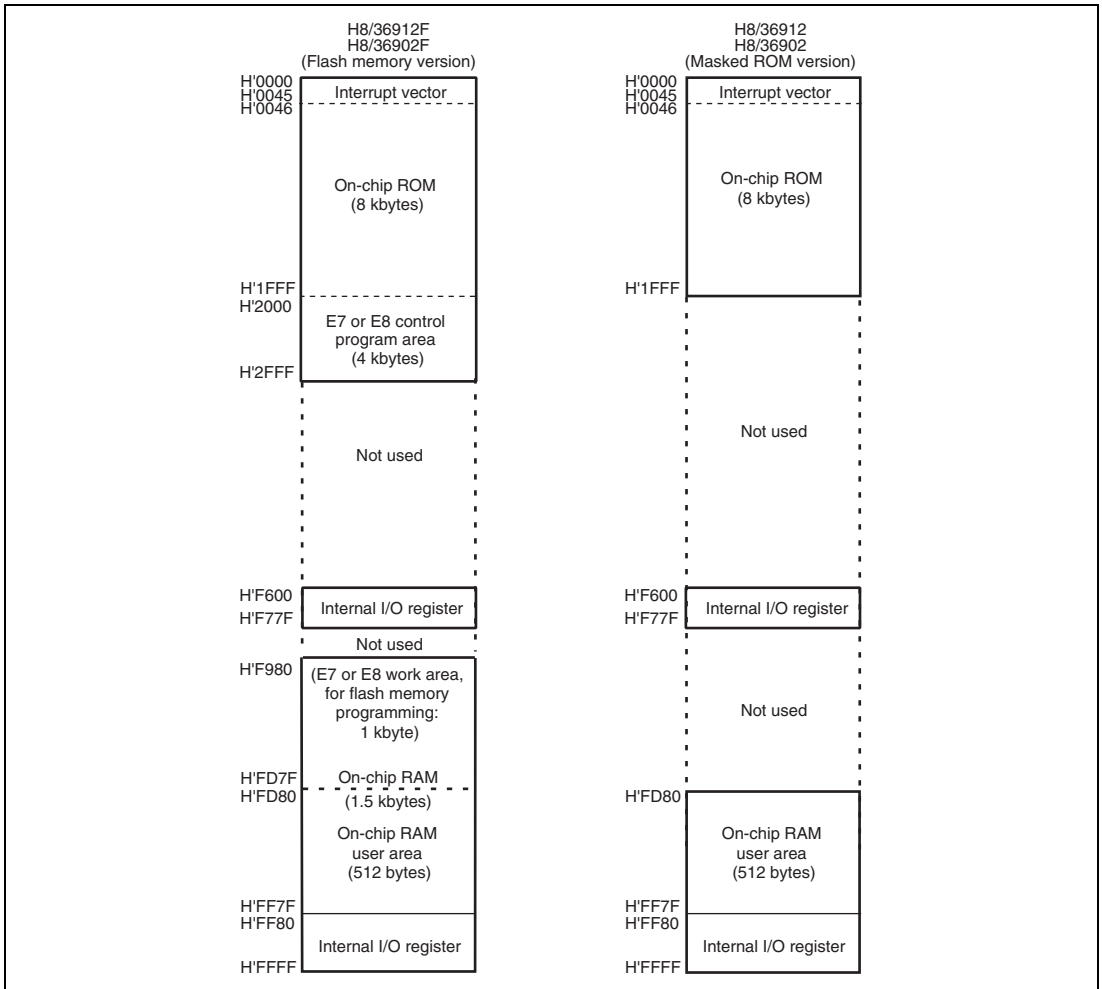

Figure 2.1 Memory Map (1)

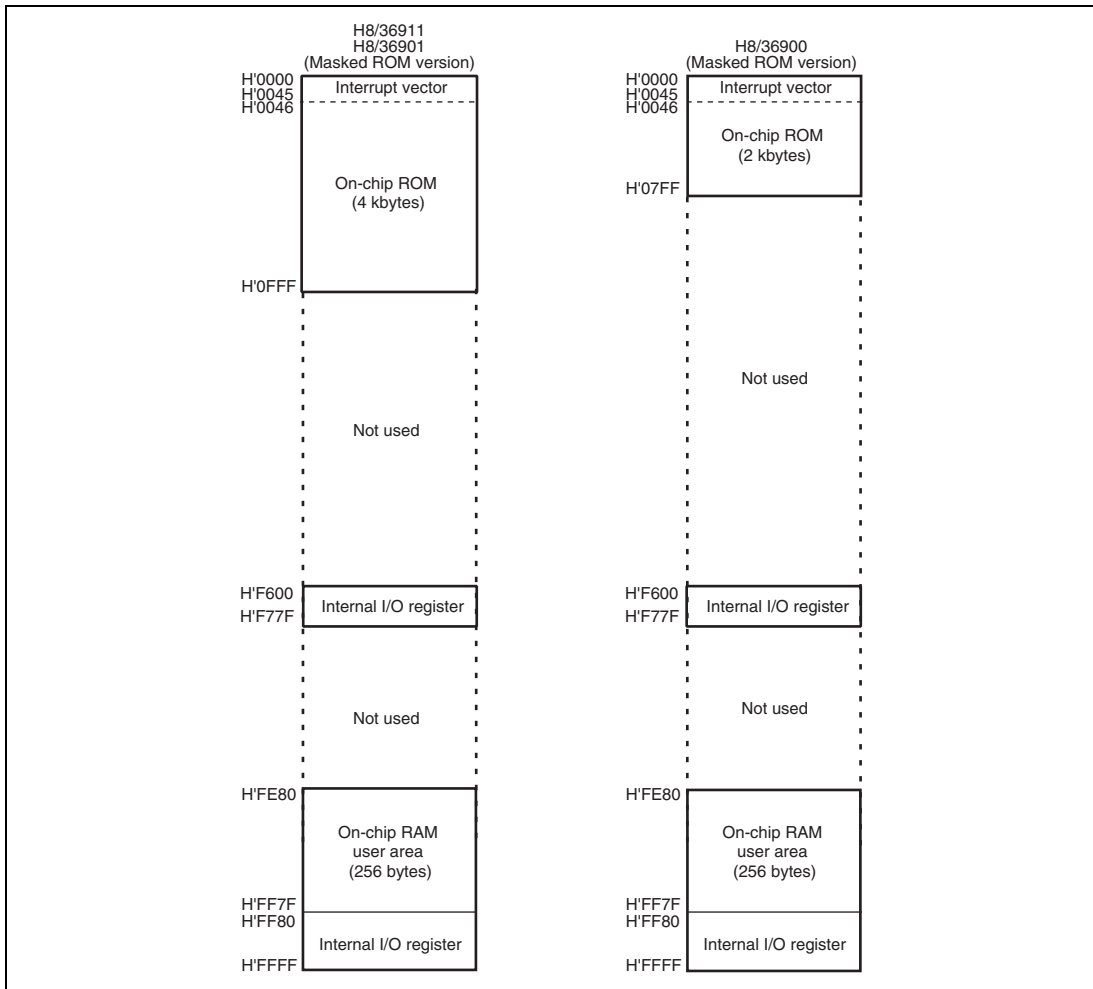

Figure 2.1 Memory Map (2)

2.2 Register Configuration

The H8/300H CPU has the internal registers shown in figure 2.2. There are two types of registers; general registers and control registers. The control registers are a 24-bit program counter (PC), and an 8-bit condition code register (CCR).

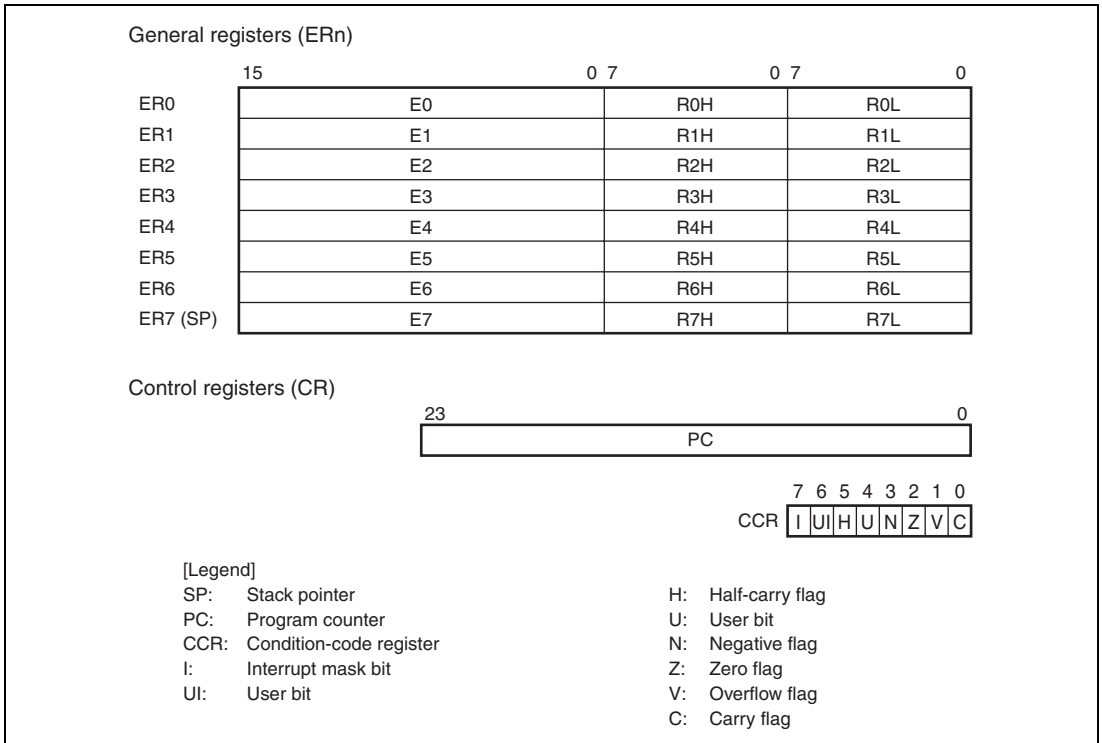

Figure 2.2 CPU Registers

2.2.1 General Registers

The H8/300H CPU has eight 32-bit general registers. These general registers are all functionally identical and can be used as both address registers and data registers. When a general register is used as a data register, it can be accessed as a 32-bit, 16-bit, or 8-bit register. Figure 2.3 illustrates the usage of the general registers. When the general registers are used as 32-bit registers or address registers, they are designated by the letters ER (ER0 to ER7).

The ER registers divide into 16-bit general registers designated by the letters E (E0 to E7) and R (R0 to R7). These registers are functionally equivalent, providing a maximum of sixteen 16-bit registers. The E registers (E0 to E7) are also referred to as extended registers.

The R registers divide into 8-bit registers designated by the letters RH (R0H to R7H) and RL (R0L to R7L). These registers are functionally equivalent, providing a maximum of sixteen 8-bit registers.

The usage of each register can be selected independently.

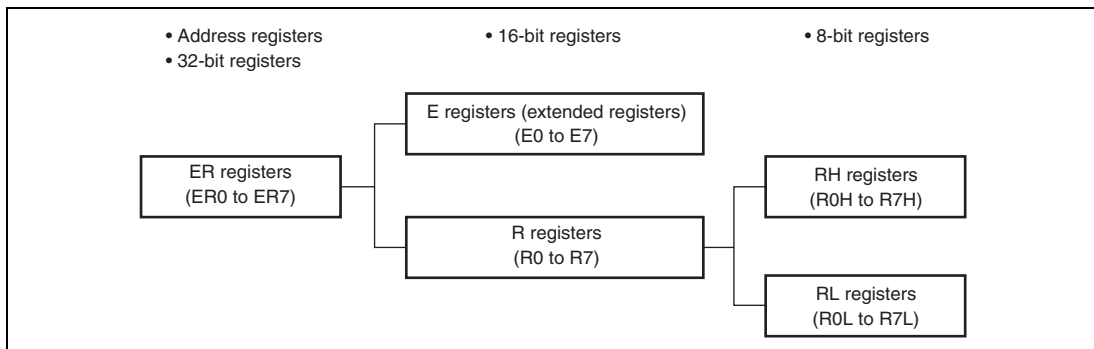

Figure 2.3 Usage of General Registers

General register ER7 has the function of stack pointer (SP) in addition to its general-register function, and is used implicitly in exception handling and subroutine calls. Figure 2.4 shows the stack.

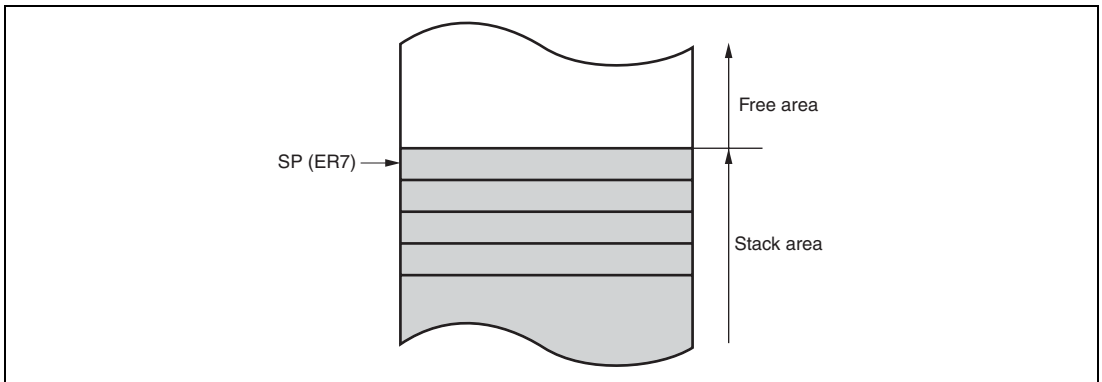

Figure 2.4 Relationship between Stack Pointer and Stack Area

2.2.2 Program Counter (PC)

This 24-bit counter indicates the address of the next instruction the CPU will execute. The length of all CPU instructions is 2 bytes (one word), so the least significant PC bit is ignored. (When an instruction is fetched, the least significant PC bit is regarded as 0). The PC is initialized when the start address is loaded by the vector address generated during reset exception-handling sequence.

2.2.3 Condition-Code Register (CCR)

This 8-bit register contains internal CPU status information, including an interrupt mask bit (I) and half-carry (H), negative (N), zero (Z), overflow (V), and carry (C) flags. The I bit is initialized to 1 by reset exception-handling sequence, but other bits are not initialized.

Some instructions leave flag bits unchanged. Operations can be performed on the CCR bits by the LDC, STC, ANDC, ORC, and XORC instructions. The N, Z, V, and C flags are used as branching conditions for conditional branch (Bcc) instructions.

For the action of each instruction on the flag bits, see appendix A.1, Instruction List.

Bit	Bit Name	Initial Value	R/W	Description
7	I	1	R/W	<p>Interrupt Mask Bit</p> <p>Masks interrupts other than NMI when set to 1. NMI is accepted regardless of the I bit setting. The I bit is set to 1 at the start of an exception-handling sequence.</p>
6	UI	Undefined	R/W	<p>User Bit</p> <p>Can be written and read by software using the LDC, STC, ANDC, ORC, and XORC instructions.</p>
5	H	Undefined	R/W	<p>Half-Carry Flag</p> <p>When the ADD.B, ADDX.B, SUB.B, SUBX.B, CMP.B, or NEG.B instruction is executed, this flag is set to 1 if there is a carry or borrow at bit 3, and cleared to 0 otherwise. When the ADD.W, SUB.W, CMP.W, or NEG.W instruction is executed, the H flag is set to 1 if there is a carry or borrow at bit 11, and cleared to 0 otherwise. When the ADD.L, SUB.L, CMP.L, or NEG.L instruction is executed, the H flag is set to 1 if there is a carry or borrow at bit 27, and cleared to 0 otherwise.</p>
4	U	Undefined	R/W	<p>User Bit</p> <p>Can be written and read by software using the LDC, STC, ANDC, ORC, and XORC instructions.</p>
3	N	Undefined	R/W	<p>Negative Flag</p> <p>Stores the value of the most significant bit of data as a sign bit.</p>
2	Z	Undefined	R/W	<p>Zero Flag</p> <p>Set to 1 to indicate zero data, and cleared to 0 to indicate non-zero data.</p>
1	V	Undefined	R/W	<p>Overflow Flag</p> <p>Set to 1 when an arithmetic overflow occurs, and cleared to 0 at other times.</p>
0	C	Undefined	R/W	<p>Carry Flag</p> <p>Set to 1 when a carry occurs, and cleared to 0 otherwise. Used by:</p> <ul style="list-style-type: none"> • Add instructions, to indicate a carry • Subtract instructions, to indicate a borrow • Shift and rotate instructions, to indicate a carry <p>The carry flag is also used as a bit accumulator by bit manipulation instructions.</p>

2.3 Data Formats

The H8/300H CPU can process 1-bit, 4-bit (BCD), 8-bit (byte), 16-bit (word), and 32-bit (longword) data. Bit-manipulation instructions operate on 1-bit data by accessing bit n ($n = 0, 1, 2, \dots, 7$) of byte operand data. The DAA and DAS decimal-adjust instructions treat byte data as two digits of 4-bit BCD data.

2.3.1 General Register Data Formats

Figure 2.5 shows the data formats in general registers.

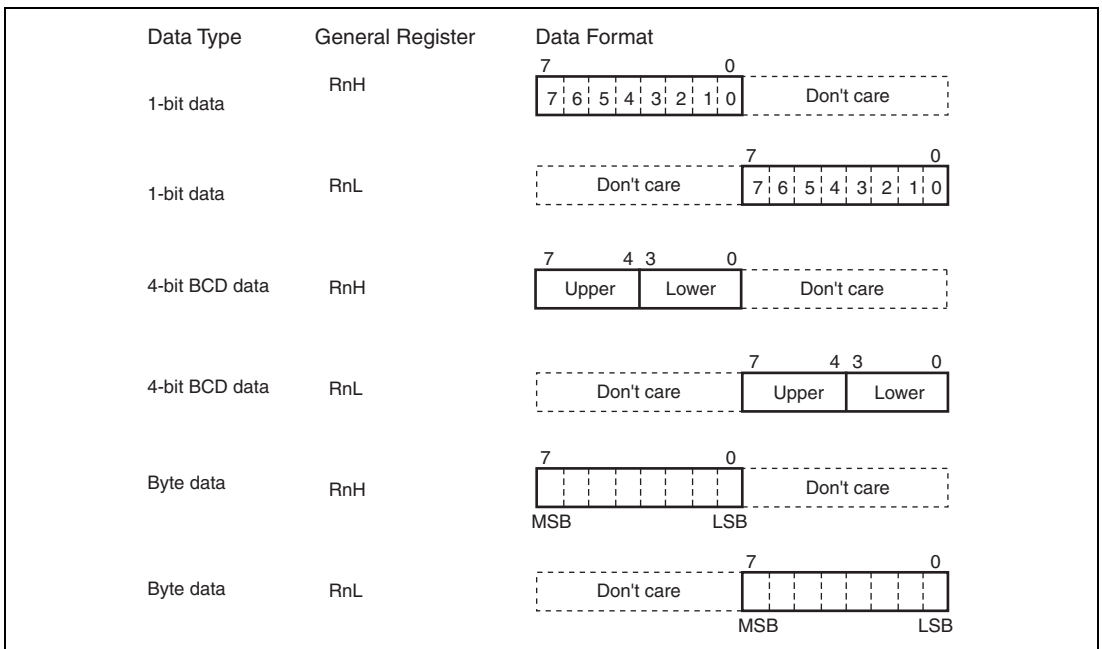

Figure 2.5 General Register Data Formats (1)

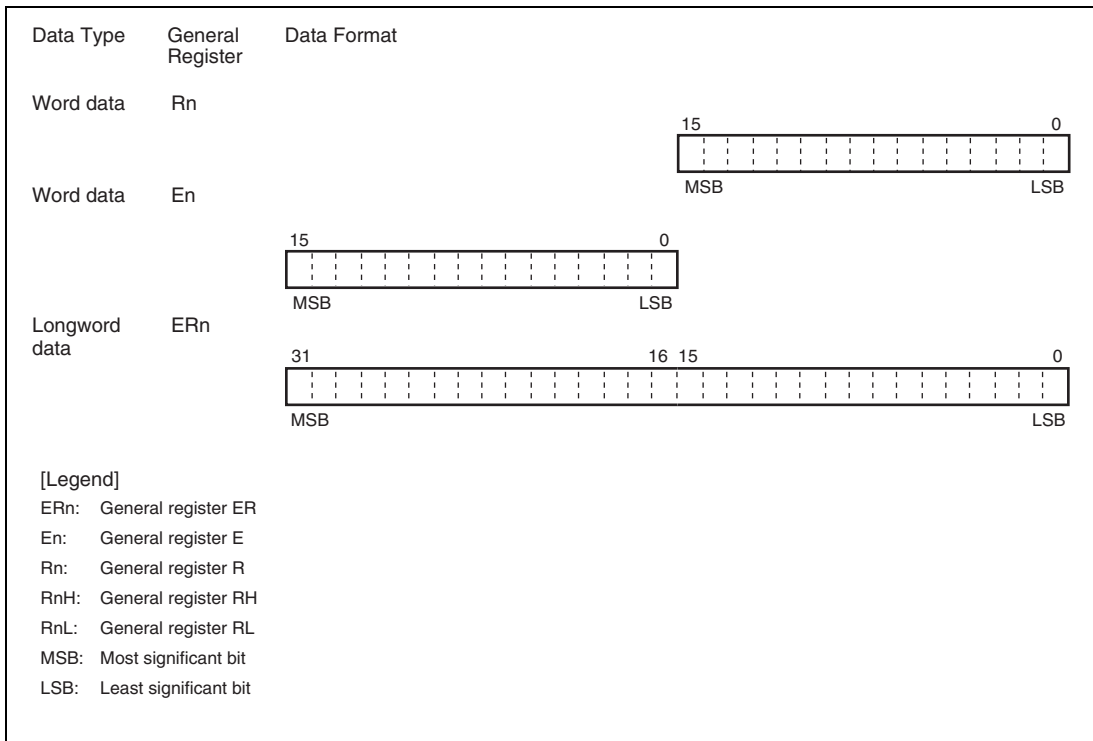

Figure 2.5 General Register Data Formats (2)

2.3.2 Memory Data Formats

Figure 2.6 shows the data formats in memory. The H8/300H CPU can access word data and longword data in memory, however word or longword data must begin at an even address. If an attempt is made to access word or longword data at an odd address, an address error does not occur, however the least significant bit of the address is regarded as 0, so access begins the preceding address. This also applies to instruction fetches.

When ER7 (SP) is used as an address register to access the stack, the operand size should be word or longword.

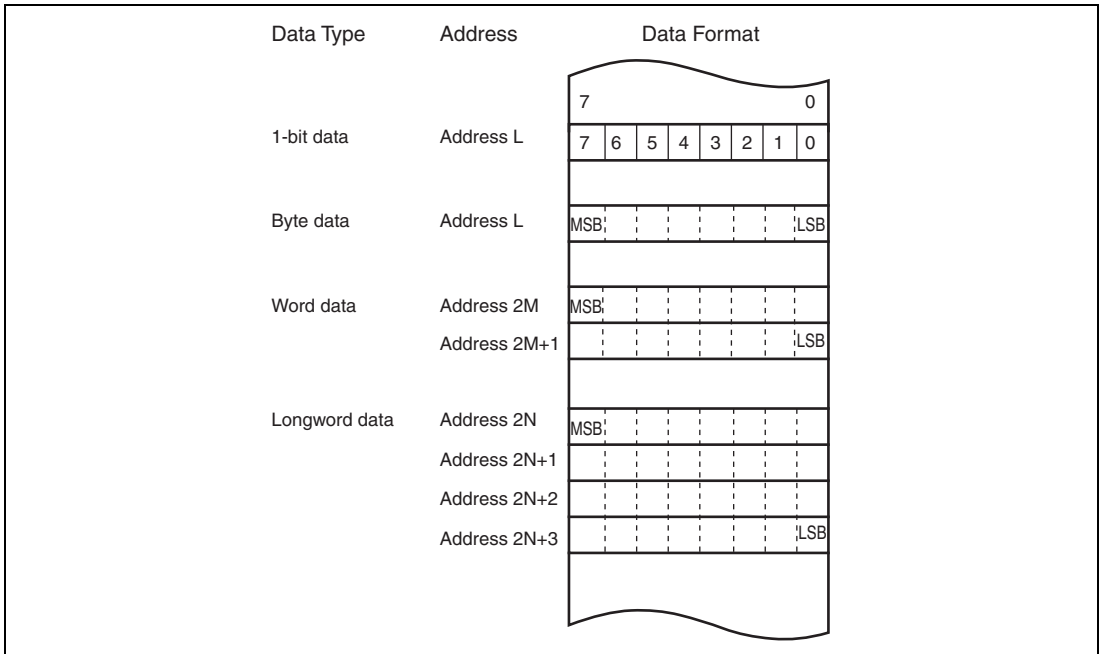

Figure 2.6 Memory Data Formats

2.4 Instruction Set

2.4.1 Table of Instructions Classified by Function

The H8/300H CPU has 62 instructions. Tables 2.2 to 2.9 summarize the instructions in each functional category. The notation used in tables 2.2 to 2.9 is defined below.

Table 2.1 Operation Notation

Symbol	Description
Rd	General register (destination)*
Rs	General register (source)*
Rn	General register*
ERn	General register (32-bit register or address register)
(EAd)	Destination operand
(EAs)	Source operand
CCR	Condition-code register
N	N (negative) flag in CCR
Z	Z (zero) flag in CCR
V	V (overflow) flag in CCR
C	C (carry) flag in CCR
PC	Program counter
SP	Stack pointer
#IMM	Immediate data
disp	Displacement
+	Addition
–	Subtraction
×	Multiplication
÷	Division
^	Logical AND
∨	Logical OR
⊕	Logical XOR
→	Move
¬	NOT (logical complement)

Symbol	Description
:3/:8/:16/:24	3-, 8-, 16-, or 24-bit length

Note: * General registers include 8-bit registers (R0H to R7H, R0L to R7L), 16-bit registers (R0 to R7, E0 to E7), and 32-bit registers/address registers (ER0 to ER7).

Table 2.2 Data Transfer Instructions

Instruction	Size*	Function
MOV	B/W/L	(EAs) → Rd, Rs → (EAd) Moves data between two general registers or between a general register and memory, or moves immediate data to a general register.
MOVFPPE	B	(EAs) → Rd, Cannot be used in this LSI.
MOVTPE	B	Rs → (EAs) Cannot be used in this LSI.
POP	W/L	@SP+ → Rn Pops a general register from the stack. POP.W Rn is identical to MOV.W @SP+, Rn. POP.L ERn is identical to MOV.L @SP+, ERn.
PUSH	W/L	Rn → @-SP Pushes a general register onto the stack. PUSH.W Rn is identical to MOV.W Rn, @-SP. PUSH.L ERn is identical to MOV.L ERn, @-SP.

Note: * Refers to the operand size.

B: Byte

W: Word

L: Longword

Table 2.3 Arithmetic Operations Instructions (1)

Instruction	Size*	Function
ADD SUB	B/W/L	$Rd \pm Rs \rightarrow Rd$, $Rd \pm \#IMM \rightarrow Rd$ Performs addition or subtraction on data in two general registers, or on immediate data and data in a general register (immediate byte data cannot be subtracted from byte data in a general register. Use the SUBX or ADD instruction.)
ADDX SUBX	B	$Rd \pm Rs \pm C \rightarrow Rd$, $Rd \pm \#IMM \pm C \rightarrow Rd$ Performs addition or subtraction with carry on byte data in two general registers, or on immediate data and data in a general register.
INC DEC	B/W/L	$Rd \pm 1 \rightarrow Rd$, $Rd \pm 2 \rightarrow Rd$ Increments or decrements a general register by 1 or 2. (Byte operands can be incremented or decremented by 1 only.)
ADDS SUBS	L	$Rd \pm 1 \rightarrow Rd$, $Rd \pm 2 \rightarrow Rd$, $Rd \pm 4 \rightarrow Rd$ Adds or subtracts the value 1, 2, or 4 to or from data in a 32-bit register.
DAA DAS	B	Rd decimal adjust $\rightarrow Rd$ Decimal-adjusts an addition or subtraction result in a general register by referring to the CCR to produce 4-bit BCD data.
MULXU	B/W	$Rd \times Rs \rightarrow Rd$ Performs unsigned multiplication on data in two general registers: either 8 bits \times 8 bits \rightarrow 16 bits or 16 bits \times 16 bits \rightarrow 32 bits.
MULXS	B/W	$Rd \times Rs \rightarrow Rd$ Performs signed multiplication on data in two general registers: either 8 bits \times 8 bits \rightarrow 16 bits or 16 bits \times 16 bits \rightarrow 32 bits.
DIVXU	B/W	$Rd \div Rs \rightarrow Rd$ Performs unsigned division on data in two general registers: either 16 bits \div 8 bits \rightarrow 8-bit quotient and 8-bit remainder or 32 bits \div 16 bits \rightarrow 16-bit quotient and 16-bit remainder.

Note: * Refers to the operand size.

B: Byte

W: Word

L: Longword

Table 2.3 Arithmetic Operations Instructions (2)

Instruction	Size*	Function
DIVXS	B/W	$Rd \div Rs \rightarrow Rd$ Performs signed division on data in two general registers: either 16 bits \div 8 bits \rightarrow 8-bit quotient and 8-bit remainder or 32 bits \div 16 bits \rightarrow 16-bit quotient and 16-bit remainder.
CMP	B/W/L	$Rd - Rs$, $Rd - \#IMM$ Compares data in a general register with data in another general register or with immediate data, and sets CCR bits according to the result.
NEG	B/W/L	$0 - Rd \rightarrow Rd$ Takes the two's complement (arithmetic complement) of data in a general register.
EXTU	W/L	Rd (zero extension) $\rightarrow Rd$ Extends the lower 8 bits of a 16-bit register to word size, or the lower 16 bits of a 32-bit register to longword size, by padding with zeros on the left.
EXTS	W/L	Rd (sign extension) $\rightarrow Rd$ Extends the lower 8 bits of a 16-bit register to word size, or the lower 16 bits of a 32-bit register to longword size, by extending the sign bit.

Note: * Refers to the operand size.

B: Byte

W: Word

L: Longword

Table 2.4 Logic Operations Instructions

Instruction	Size*	Function
AND	B/W/L	$Rd \wedge Rs \rightarrow Rd$, $Rd \wedge \#IMM \rightarrow Rd$ Performs a logical AND operation on a general register and another general register or immediate data.
OR	B/W/L	$Rd \vee Rs \rightarrow Rd$, $Rd \vee \#IMM \rightarrow Rd$ Performs a logical OR operation on a general register and another general register or immediate data.
XOR	B/W/L	$Rd \oplus Rs \rightarrow Rd$, $Rd \oplus \#IMM \rightarrow Rd$ Performs a logical exclusive OR operation on a general register and another general register or immediate data.
NOT	B/W/L	$\neg (Rd) \rightarrow (Rd)$ Takes the one's complement of general register contents.

Note: * Refers to the operand size.

B: Byte

W: Word

L: Longword

Table 2.5 Shift Instructions

Instruction	Size*	Function
SHAL SHAR	B/W/L	$Rd \text{ (shift)} \rightarrow Rd$ Performs an arithmetic shift on general register contents.
SLL SHLR	B/W/L	$Rd \text{ (shift)} \rightarrow Rd$ Performs a logical shift on general register contents.
ROTL ROTR	B/W/L	$Rd \text{ (rotate)} \rightarrow Rd$ Rotates general register contents.
ROTXL ROTXR	B/W/L	$Rd \text{ (rotate)} \rightarrow Rd$ Rotates general register contents through the carry flag.

Note: * Refers to the operand size.

B: Byte

W: Word

L: Longword

Table 2.6 Bit Manipulation Instructions (1)

Instruction	Size*	Function
BSET	B	1 → (<bit-No.> of <EAd>) Sets a specified bit in a general register or memory operand to 1. The bit number is specified by 3-bit immediate data or the lower three bits of a general register.
BCLR	B	0 → (<bit-No.> of <EAd>) Clears a specified bit in a general register or memory operand to 0. The bit number is specified by 3-bit immediate data or the lower three bits of a general register.
BNOT	B	\neg (<bit-No.> of <EAd>) → (<bit-No.> of <EAd>) Inverts a specified bit in a general register or memory operand. The bit number is specified by 3-bit immediate data or the lower three bits of a general register.
BTST	B	\neg (<bit-No.> of <EAd>) → Z Tests a specified bit in a general register or memory operand and sets or clears the Z flag accordingly. The bit number is specified by 3-bit immediate data or the lower three bits of a general register.
BAND	B	$C \wedge$ (<bit-No.> of <EAd>) → C ANDs the carry flag with a specified bit in a general register or memory operand and stores the result in the carry flag.
BIAND	B	$C \wedge \neg$ (<bit-No.> of <EAd>) → C ANDs the carry flag with the inverse of a specified bit in a general register or memory operand and stores the result in the carry flag. The bit number is specified by 3-bit immediate data.
BOR	B	$C \vee$ (<bit-No.> of <EAd>) → C ORs the carry flag with a specified bit in a general register or memory operand and stores the result in the carry flag.
BIOR	B	$C \vee \neg$ (<bit-No.> of <EAd>) → C ORs the carry flag with the inverse of a specified bit in a general register or memory operand and stores the result in the carry flag. The bit number is specified by 3-bit immediate data.

Note: * Refers to the operand size.

B: Byte

Table 2.6 Bit Manipulation Instructions (2)

Instruction	Size*	Function
BXOR	B	$C \oplus \langle \text{bit-No.} \rangle \text{ of } \langle \text{EAd} \rangle \rightarrow C$ XORs the carry flag with a specified bit in a general register or memory operand and stores the result in the carry flag.
BIXOR	B	$C \oplus \neg \langle \text{bit-No.} \rangle \text{ of } \langle \text{EAd} \rangle \rightarrow C$ XORs the carry flag with the inverse of a specified bit in a general register or memory operand and stores the result in the carry flag. The bit number is specified by 3-bit immediate data.
BLD	B	$\langle \text{bit-No.} \rangle \text{ of } \langle \text{EAd} \rangle \rightarrow C$ Transfers a specified bit in a general register or memory operand to the carry flag.
BILD	B	$\neg \langle \text{bit-No.} \rangle \text{ of } \langle \text{EAd} \rangle \rightarrow C$ Transfers the inverse of a specified bit in a general register or memory operand to the carry flag. The bit number is specified by 3-bit immediate data.
BST	B	$C \rightarrow \langle \text{bit-No.} \rangle \text{ of } \langle \text{EAd} \rangle$ Transfers the carry flag value to a specified bit in a general register or memory operand.
BIST	B	$\neg C \rightarrow \langle \text{bit-No.} \rangle \text{ of } \langle \text{EAd} \rangle$ Transfers the inverse of the carry flag value to a specified bit in a general register or memory operand. The bit number is specified by 3-bit immediate data.

Note: * Refers to the operand size.

B: Byte

Table 2.7 Branch Instructions

Instruction	Size	Function																																																			
Bcc*	—	Branches to a specified address if a specified condition is true. The branching conditions are listed below.																																																			
		<table border="1"> <thead> <tr> <th>Mnemonic</th> <th>Description</th> <th>Condition</th> </tr> </thead> <tbody> <tr> <td>BRA(BT)</td> <td>Always (true)</td> <td>Always</td> </tr> <tr> <td>BRN(BF)</td> <td>Never (false)</td> <td>Never</td> </tr> <tr> <td>BHI</td> <td>High</td> <td>$C \vee Z = 0$</td> </tr> <tr> <td>BLS</td> <td>Low or same</td> <td>$C \vee Z = 1$</td> </tr> <tr> <td>BCC(BHS)</td> <td>Carry clear (high or same)</td> <td>$C = 0$</td> </tr> <tr> <td>BCS(BLO)</td> <td>Carry set (low)</td> <td>$C = 1$</td> </tr> <tr> <td>BNE</td> <td>Not equal</td> <td>$Z = 0$</td> </tr> <tr> <td>BEQ</td> <td>Equal</td> <td>$Z = 1$</td> </tr> <tr> <td>BVC</td> <td>Overflow clear</td> <td>$V = 0$</td> </tr> <tr> <td>BVS</td> <td>Overflow set</td> <td>$V = 1$</td> </tr> <tr> <td>BPL</td> <td>Plus</td> <td>$N = 0$</td> </tr> <tr> <td>BMI</td> <td>Minus</td> <td>$N = 1$</td> </tr> <tr> <td>BGE</td> <td>Greater or equal</td> <td>$N \oplus V = 0$</td> </tr> <tr> <td>BLT</td> <td>Less than</td> <td>$N \oplus V = 1$</td> </tr> <tr> <td>BGT</td> <td>Greater than</td> <td>$Z \vee (N \oplus V) = 0$</td> </tr> <tr> <td>BLE</td> <td>Less or equal</td> <td>$Z \vee (N \oplus V) = 1$</td> </tr> </tbody> </table>	Mnemonic	Description	Condition	BRA(BT)	Always (true)	Always	BRN(BF)	Never (false)	Never	BHI	High	$C \vee Z = 0$	BLS	Low or same	$C \vee Z = 1$	BCC(BHS)	Carry clear (high or same)	$C = 0$	BCS(BLO)	Carry set (low)	$C = 1$	BNE	Not equal	$Z = 0$	BEQ	Equal	$Z = 1$	BVC	Overflow clear	$V = 0$	BVS	Overflow set	$V = 1$	BPL	Plus	$N = 0$	BMI	Minus	$N = 1$	BGE	Greater or equal	$N \oplus V = 0$	BLT	Less than	$N \oplus V = 1$	BGT	Greater than	$Z \vee (N \oplus V) = 0$	BLE	Less or equal	$Z \vee (N \oplus V) = 1$
Mnemonic	Description	Condition																																																			
BRA(BT)	Always (true)	Always																																																			
BRN(BF)	Never (false)	Never																																																			
BHI	High	$C \vee Z = 0$																																																			
BLS	Low or same	$C \vee Z = 1$																																																			
BCC(BHS)	Carry clear (high or same)	$C = 0$																																																			
BCS(BLO)	Carry set (low)	$C = 1$																																																			
BNE	Not equal	$Z = 0$																																																			
BEQ	Equal	$Z = 1$																																																			
BVC	Overflow clear	$V = 0$																																																			
BVS	Overflow set	$V = 1$																																																			
BPL	Plus	$N = 0$																																																			
BMI	Minus	$N = 1$																																																			
BGE	Greater or equal	$N \oplus V = 0$																																																			
BLT	Less than	$N \oplus V = 1$																																																			
BGT	Greater than	$Z \vee (N \oplus V) = 0$																																																			
BLE	Less or equal	$Z \vee (N \oplus V) = 1$																																																			
JMP	—	Branches unconditionally to a specified address.																																																			
BSR	—	Branches to a subroutine at a specified address.																																																			
JSR	—	Branches to a subroutine at a specified address.																																																			
RTS	—	Returns from a subroutine																																																			

Note: * Bcc is the general name for conditional branch instructions.

Table 2.8 System Control Instructions

Instruction	Size*	Function
TRAPA	—	Starts trap-instruction exception handling.
RTE	—	Returns from an exception-handling routine.
SLEEP	—	Causes a transition to a power-down state.
LDC	B/W	(EAs) → CCR Moves the source operand contents to the CCR. The CCR size is one byte, but in transfer from memory, data is read by word access.
STC	B/W	CCR → (EAd), EXR → (EAd) Transfers the CCR contents to a destination location. The condition code register size is one byte, but in transfer to memory, data is written by word access.
ANDC	B	CCR ∧ #IMM → CCR, EXR ∧ #IMM → EXR Logically ANDs the CCR with immediate data.
ORC	B	CCR ∨ #IMM → CCR, EXR ∨ #IMM → EXR Logically ORs the CCR with immediate data.
XORC	B	CCR ⊕ #IMM → CCR, EXR ⊕ #IMM → EXR Logically XORs the CCR with immediate data.
NOP	—	PC + 2 → PC Only increments the program counter.

Note: * Refers to the operand size.

B: Byte
W: Word

Table 2.9 Block Data Transfer Instructions

Instruction	Size	Function
EEPMOV.B	—	if R4L \neq 0 then Repeat @ER5+ \rightarrow @ER6+, R4L-1 \rightarrow R4L Until R4L = 0 else next;
EEPMOV.W	—	if R4 \neq 0 then Repeat @ER5+ \rightarrow @ER6+, R4-1 \rightarrow R4 Until R4 = 0 else next; Transfers a data block. Starting from the address set in ER5, transfers data for the number of bytes set in R4L or R4 to the address location set in ER6. Execution of the next instruction begins as soon as the transfer is completed.

2.4.2 Basic Instruction Formats

H8/300H CPU instructions consist of 2-byte (1-word) units. An instruction consists of an operation field (op field), a register field (r field), an effective address extension (EA field), and a condition field (cc).

Figure 2.7 shows examples of instruction formats.

(1) Operation Field

Indicates the function of the instruction, the addressing mode, and the operation to be carried out on the operand. The operation field always includes the first four bits of the instruction. Some instructions have two operation fields.

(2) Register Field

Specifies a general register. Address registers are specified by 3 bits, and data registers by 3 bits or 4 bits. Some instructions have two register fields. Some have no register field.

(3) Effective Address Extension

8, 16, or 32 bits specifying immediate data, an absolute address, or a displacement. A24-bit address or displacement is treated as a 32-bit data in which the first 8 bits are 0 (H'00).

(4) Condition Field

Specifies the branching condition of Bcc instructions.

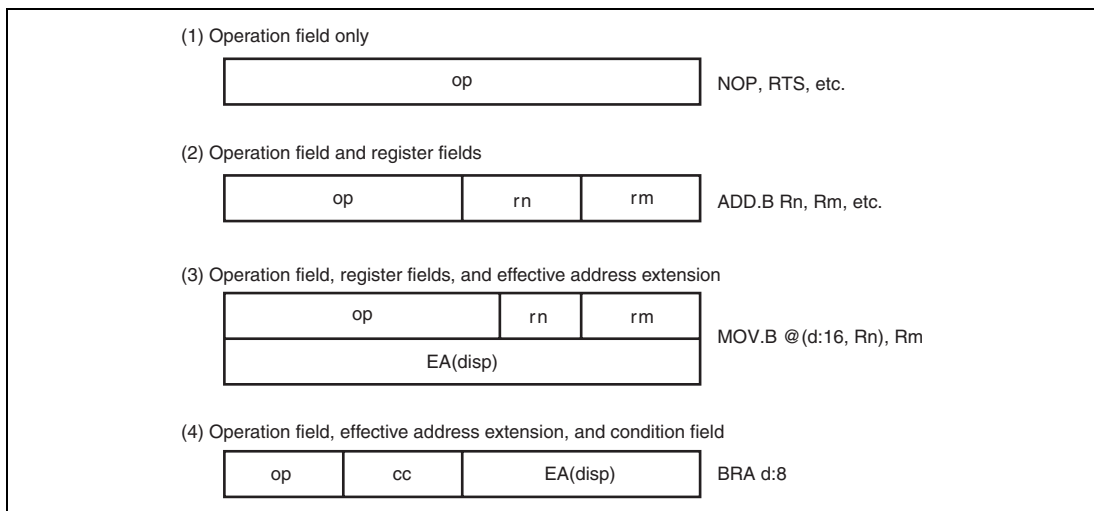

Figure 2.7 Instruction Formats

2.5 Addressing Modes and Effective Address Calculation

The following describes the H8/300H CPU. In this LSI, the upper eight bits are ignored in the generated 24-bit address, so the effective address is 16 bits.

2.5.1 Addressing Modes

The H8/300H CPU supports the eight addressing modes listed in table 2.10. Each instruction uses a subset of these addressing modes. Addressing modes that can be used differ depending on the instruction. For details, refer to appendix A.4, Combinations of Instructions and Addressing Modes.

Arithmetic and logic instructions can use the register direct and immediate modes. Data transfer instructions can use all addressing modes except program-counter relative and memory indirect. Bit manipulation instructions use register direct, register indirect, or the absolute addressing mode to specify an operand, and register direct (BSET, BCLR, BNOT, and BTST instructions) or immediate (3-bit) addressing mode to specify a bit number in the operand.

Table 2.10 Addressing Modes

No.	Addressing Mode	Symbol
1	Register direct	Rn
2	Register indirect	@ERn
3	Register indirect with displacement	@(d:16,ERn)/@(d:24,ERn)
4	Register indirect with post-increment Register indirect with pre-decrement	@ERn+ @-ERn
5	Absolute address	@aa:8/@aa:16/@aa:24
6	Immediate	#xx:8/#xx:16/#xx:32
7	Program-counter relative	@(d:8,PC)/@(d:16,PC)
8	Memory indirect	@@aa:8

(1) Register Direct—Rn

The register field of the instruction specifies an 8-, 16-, or 32-bit general register containing the operand. R0H to R7H and R0L to R7L can be specified as 8-bit registers. R0 to R7 and E0 to E7 can be specified as 16-bit registers. ER0 to ER7 can be specified as 32-bit registers.

(2) Register Indirect—@ERn

The register field of the instruction code specifies an address register (ERn), the lower 24 bits of which contain the address of the operand on memory.

(3) Register Indirect with Displacement—@(d:16, ERn) or @(d:24, ERn)

A 16-bit or 24-bit displacement contained in the instruction is added to an address register (ERn) specified by the register field of the instruction, and the lower 24 bits of the sum the address of a memory operand. A 16-bit displacement is sign-extended when added.

(4) Register Indirect with Post-Increment or Pre-Decrement—@ERn+ or @-ERn**• Register indirect with post-increment—@ERn+**

The register field of the instruction code specifies an address register (ERn) the lower 24 bits of which contains the address of a memory operand. After the operand is accessed, 1, 2, or 4 is added to the address register contents (32 bits) and the sum is stored in the address register. The value added is 1 for byte access, 2 for word access, or 4 for longword access. For the word or longword access, the register value should be even.

• Register indirect with pre-decrement—@-ERn

The value 1, 2, or 4 is subtracted from an address register (ERn) specified by the register field in the instruction code, and the lower 24 bits of the result is the address of a memory operand. The result is also stored in the address register. The value subtracted is 1 for byte access, 2 for word access, or 4 for longword access. For the word or longword access, the register value should be even.

(5) Absolute Address—@aa:8, @aa:16, @aa:24

The instruction code contains the absolute address of a memory operand. The absolute address may be 8 bits long (@aa:8), 16 bits long (@aa:16), 24 bits long (@aa:24)

For an 8-bit absolute address, the upper 16 bits are all assumed to be 1 (H'FFFF). For a 16-bit absolute address the upper 8 bits are a sign extension. A 24-bit absolute address can access the entire address space.

The access ranges of absolute addresses for the group of this LSI are those shown in table 2.11, because the upper 8 bits are ignored.

Table 2.11 Absolute Address Access Ranges

Absolute Address	Access Range
8 bits (@aa:8)	H'FF00 to H'FFFF
16 bits (@aa:16)	H'0000 to H'FFFF
24 bits (@aa:24)	H'0000 to H'FFFF

(6) Immediate—#xx:8, #xx:16, or #xx:32

The instruction contains 8-bit (#xx:8), 16-bit (#xx:16), or 32-bit (#xx:32) immediate data as an operand.

The ADDS, SUBS, INC, and DEC instructions contain immediate data implicitly. Some bit manipulation instructions contain 3-bit immediate data in the instruction code, specifying a bit number. The TRAPA instruction contains 2-bit immediate data in its instruction code, specifying a vector address.

(7) Program-Counter Relative—@(d:8, PC) or @(d:16, PC)

This mode is used in the BSR instruction. An 8-bit or 16-bit displacement contained in the instruction is sign-extended and added to the 24-bit PC contents to generate a branch address. The PC value to which the displacement is added is the address of the first byte of the next instruction, so the possible branching range is -126 to $+128$ bytes (-63 to $+64$ words) or -32766 to $+32768$ bytes (-16383 to $+16384$ words) from the branch instruction. The resulting value should be an even number.

(8) Memory Indirect—@@aa:8

This mode can be used by the JMP and JSR instructions. The instruction code contains an 8-bit absolute address specifying a memory operand. This memory operand contains a branch address. The memory operand is accessed by longword access. The first byte of the memory operand is ignored, generating a 24-bit branch address. Figure 2.8 shows how to specify branch address for in memory indirect mode. The upper bits of the absolute address are all assumed to be 0, so the address range is 0 to 255 (H'0000 to H'00FF).

Note that the first part of the address range is also the exception vector area.

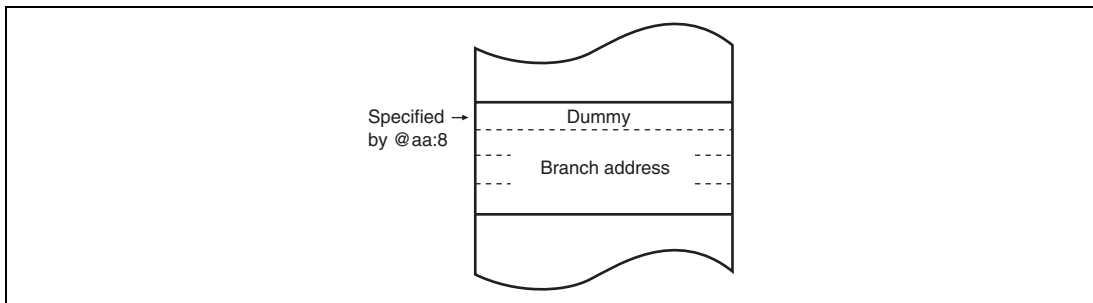

Figure 2.8 Branch Address Specification in Memory Indirect Mode

2.5.2 Effective Address Calculation

Table 2.12 indicates how effective addresses are calculated in each addressing mode. In this LSI, the upper 8 bits of the effective address are ignored in order to generate a 16-bit effective address.

Table 2.12 Effective Address Calculation (1)











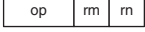

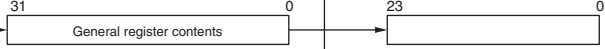

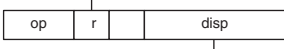
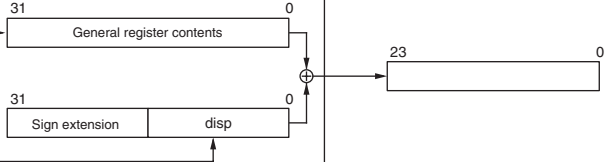
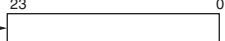
No	Addressing Mode and Instruction Format	Effective Address Calculation	Effective Address (EA)
1	Register direct(Rn) 		Operand is general register contents.
2	Register indirect(@ERn) 		
3	Register indirect with displacement @d:(d:16,ERn) or @ (d:24,ERn) 		
4	Register indirect with post-increment or pre-decrement •Register indirect with post-increment @ERn+  •Register indirect with pre-decrement @-ERn 	 <p>The value to be added or subtracted is 1 when the operand is byte size, 2 for word size, and 4 for longword size.</p>	 

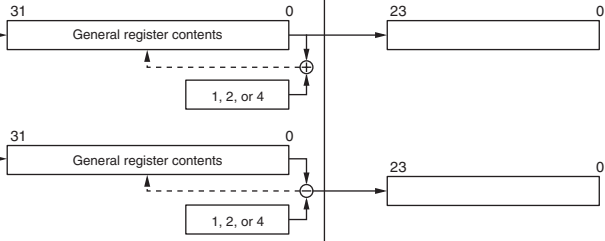
Table 2.12 Effective Address Calculation (2)

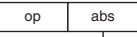
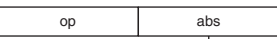
No	Addressing Mode and Instruction Format	Effective Address Calculation	Effective Address (EA)
5	Absolute address @aa:8  @aa:16  @aa:24 		  
6	Immediate #xx:8/#xx:16/#xx:32 		Operand is immediate data.
7	Program-counter relative @(d:8,PC) @(d:16,PC) 		
8	Memory indirect @aa:8 		

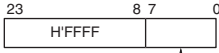
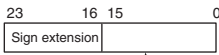
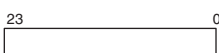
[Legend]

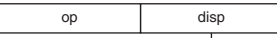
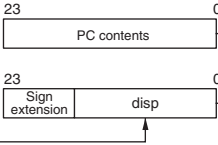
- r, rm, rn : Register field
- op : Operation field
- disp : Displacement
- IMM : Immediate data
- abs : Absolute address

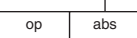
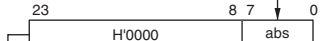
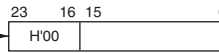
2.6 Basic Bus Cycle

CPU operation is synchronized by a system clock (ϕ). The period from a rising edge of ϕ to the next rising edge is called one state. A bus cycle consists of two states or three states. The cycle differs depending on whether access is to on-chip memory or to on-chip peripheral modules.

2.6.1 Access to On-Chip Memory (RAM, ROM)

Access to on-chip memory takes place in two states. The data bus width is 16 bits, allowing access in byte or word size. Figure 2.9 shows the on-chip memory access cycle.

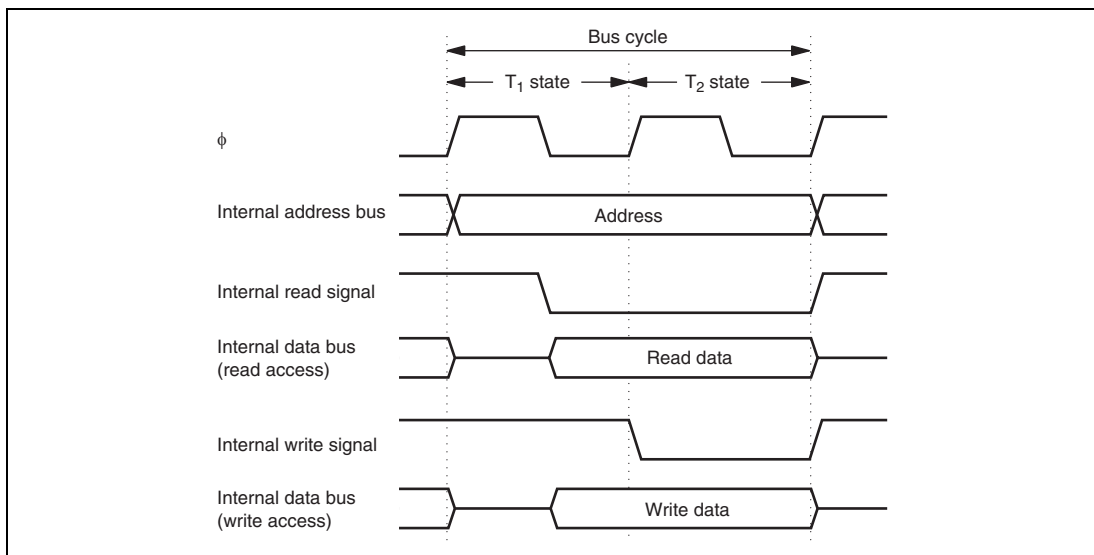

Figure 2.9 On-Chip Memory Access Cycle

2.6.2 On-Chip Peripheral Modules

On-chip peripheral modules are accessed in two states or three states. The data bus width is 8 bits or 16 bits depending on the register. For description on the data bus width and number of accessing states of each register, refer to section 19.1, Register Addresses (Address Order). Registers with 16-bit data bus width can be accessed by word size only. Registers with 8-bit data bus width can be accessed by byte or word size. When a register with 8-bit data bus width is accessed by word size, a bus cycle occurs twice. In two-state access, the operation timing is the same as that for on-chip memory.

Figure 2.10 shows the operation timing in the case of three-state access to an on-chip peripheral module.

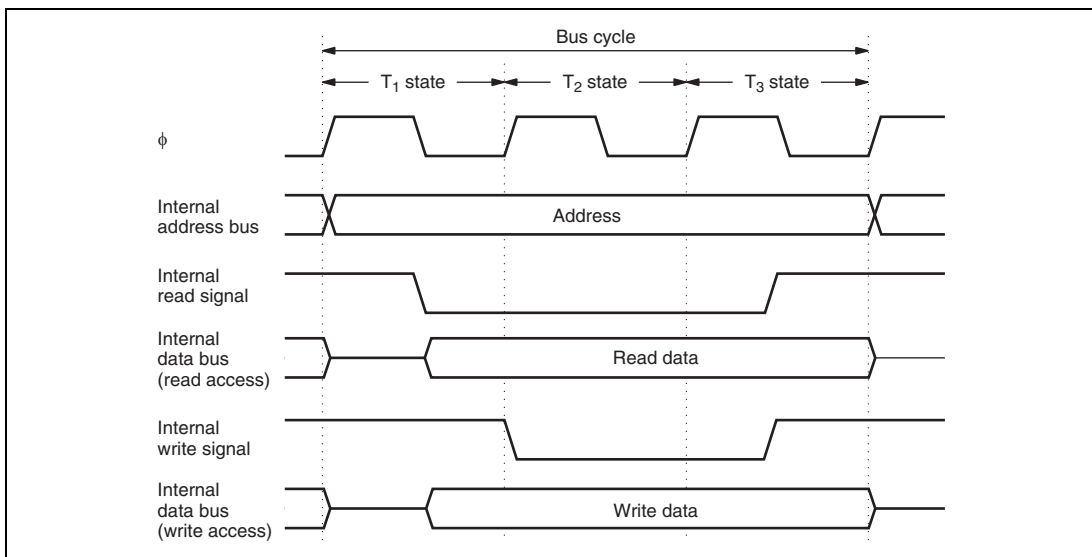

Figure 2.10 On-Chip Peripheral Module Access Cycle (3-State Access)

2.7 CPU States

There are four CPU states: the reset state, program execution state, program halt state, and exception-handling state. The program execution state includes active mode. In the program halt state there are a sleep mode, and standby mode. These states are shown in figure 2.11. Figure 2.12 shows the state transitions. For details on program execution state and program halt state, refer to section 6, Power-Down Modes. For details on exception processing, refer to section 3, Exception Handling.

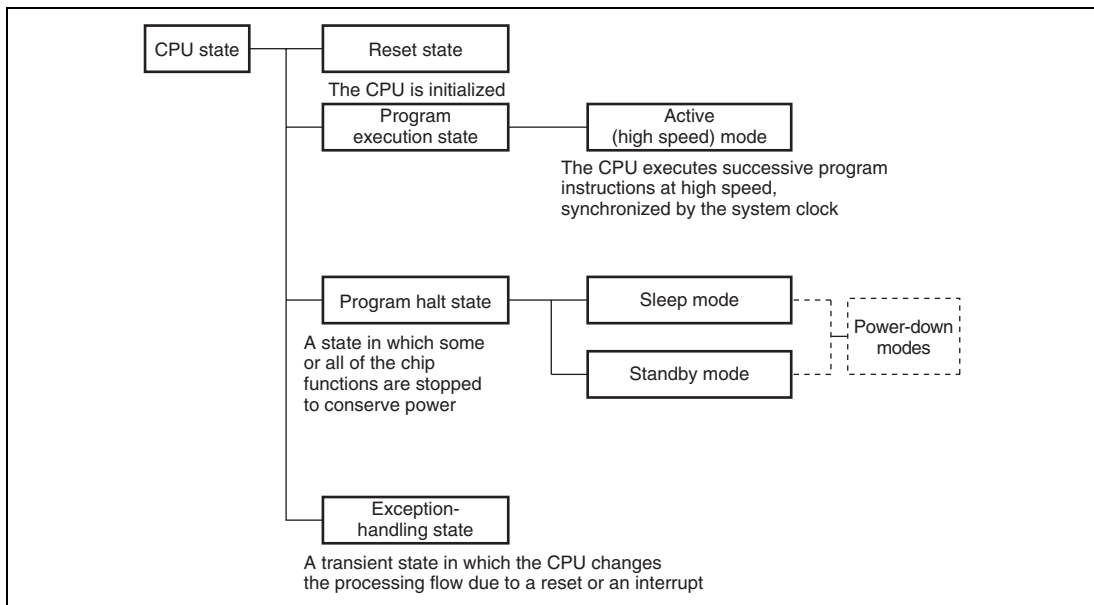

Figure 2.11 CPU Operation States

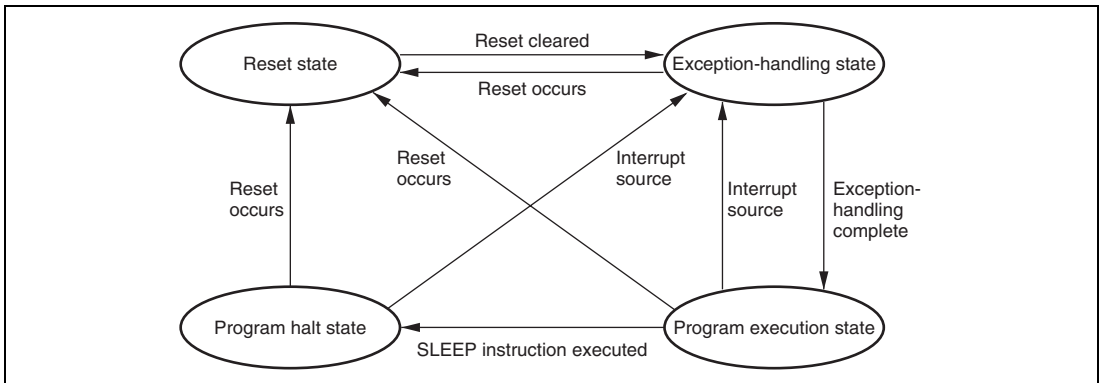

Figure 2.12 State Transitions

2.8 Usage Notes

2.8.1 Notes on Data Access to Empty Areas

The address space of this LSI includes empty areas in addition to the ROM, RAM, and on-chip I/O registers areas available to the user. When data is transferred from CPU to empty areas, the transferred data will be lost. This action may also cause the CPU to malfunction. When data is transferred from an empty area to CPU, the contents of the data cannot be guaranteed.

2.8.2 EEPMOV Instruction

EEPMOV is a block-transfer instruction and transfers the byte size of data indicated by R4L, which starts from the address indicated by R5, to the address indicated by R6. Set R4L and R6 so that the end address of the destination address (value of R6 + R4L) does not exceed H'FFFF (the value of R6 must not change from H'FFFF to H'0000 during execution).

2.8.3 Bit Manipulation Instruction

The BSET, BCLR, BNOT, BST, and BIST instructions read data from the specified address in byte units, manipulate the data of the target bit, and write data to the same address again in byte units. Special care is required when using these instructions in cases where two registers are assigned to the same address or when a bit is directly manipulated for a port, because this may rewrite data of a bit other than the bit to be manipulated.

(1) Bit Manipulation for Two Registers Assigned to the Same Address

Example 1: Bit manipulation for the timer load register and timer counter

(Applicable to timer B1, not available for the H8/36902 Group.)

Figure 2.13 shows an example of a timer in which two timer registers are assigned to the same address. When a bit manipulation instruction accesses the timer load register and timer counter of a reloadable timer, since these two registers share the same address, the following operations takes place.

1. Data is read in byte units.
2. The CPU sets or resets the bit to be manipulated with the bit manipulation instruction.
3. The written data is written again in byte units to the timer load register.

The timer is counting, so the value read is not necessarily the same as the value in the timer load register. As a result, bits other than the intended bit in the timer counter may be modified and the modified value may be written to the timer load register.

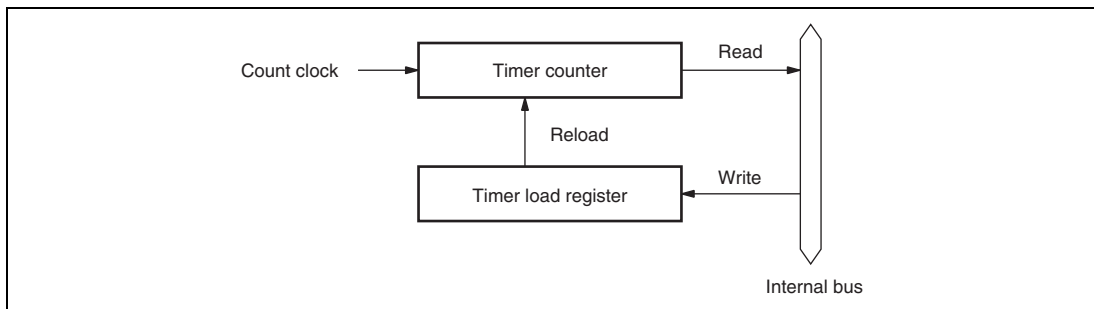

Figure 2.13 Example of Timer Configuration with Two Registers Allocated to Same Address

Example 2: The BSET instruction is executed for port 5.

P57 and P56 are input pins, with a low-level signal input at P57 and a high-level signal input at P56. P55 to P50 are output pins and output low-level signals. An example to output a high-level signal at P50 with a BSET instruction is shown below.

[Prior to executing BSET]

	P57	P56	P55	P54	P53	P52	P51	P50
Input/output	Input	Input	Output	Output	Output	Output	Output	Output
Pin state	Low level	High level	Low level	Low level	Low level	Low level	Low level	Low level
PCR5	0	0	1	1	1	1	1	1
PDR5	1	0	0	0	0	0	0	0

[BSET instruction executed]

```
BSET #0, @PDR5
```

The BSET instruction is executed for port 5.

[After executing BSET]

	P57	P56	P55	P54	P53	P52	P51	P50
Input/output	Input	Input	Output	Output	Output	Output	Output	Output
Pin state	Low level	High level	Low level	Low level	Low level	Low level	Low level	High level
PCR5	0	0	1	1	1	1	1	1
PDR5	0	1	0	0	0	0	0	1

[Description on operation]

1. When the BSET instruction is executed, first the CPU reads port 5. Since P57 and P56 are input pins, the CPU reads the pin states (low-level and high-level input). P55 to P50 are output pins, so the CPU reads the value in PDR5. In this example PDR5 has a value of H'80, but the value read by the CPU is H'40.
2. Next, the CPU sets bit 0 of the read data to 1, changing the PDR5 data to H'41.
3. Finally, the CPU writes H'41 to PDR5, completing execution of BSET.

As a result of the BSET instruction, bit 0 in PDR5 becomes 1, and P50 outputs a high-level signal. However, bits 7 and 6 of PDR5 end up with different values. To prevent this problem, store a copy of the PDR5 data in a work area in memory. Perform the bit manipulation on the data in the work area, then write this data to PDR5.

[Prior to executing BSET]

```
MOV.B #80, R0L
MOV.B R0L, @RAM0
MOV.B R0L, @PDR5
```

The PDR5 value (H'80) is written to a work area in memory (RAM0) as well as to PDR5.

	P57	P56	P55	P54	P53	P52	P51	P50
Input/output	Input	Input	Output	Output	Output	Output	Output	Output
Pin state	Low level	High level	Low level	Low level	Low level	Low level	Low level	Low level
PCR5	0	0	1	1	1	1	1	1
PDR5	1	0	0	0	0	0	0	0
RAM0	1	0	0	0	0	0	0	0

[BSET instruction executed]

```
BSET #0, @RAM0
```

The BSET instruction is executed designating the PDR5 work area (RAM0).

[After executing BSET]

```
MOV.B @RAM0, R0L
MOV.B R0L, @PDR5
```

The work area (RAM0) value is written to PDR5.

	P57	P56	P55	P54	P53	P52	P51	P50
Input/output	Input	Input	Output	Output	Output	Output	Output	Output
Pin state	Low level	High level	Low level	Low level	Low level	Low level	Low level	High level
PCR5	0	0	1	1	1	1	1	1
PDR5	1	0	0	0	0	0	0	1
RAM0	1	0	0	0	0	0	0	1

(2) Bit Manipulation in a Register Containing a Write-Only Bit

Example 3: BCLR instruction executed designating port 5 control register PCR5

P57 and P56 are input pins, with a low-level signal input at P57 and a high-level signal input at P56. P55 to P50 are output pins that output low-level signals. An example of setting the P50 pin as an input pin by the BCLR instruction is shown below. It is assumed that a high-level signal will be input to this input pin.

[Prior to executing BCLR]

	P57	P56	P55	P54	P53	P52	P51	P50
Input/output	Input	Input	Output	Output	Output	Output	Output	Output
Pin state	Low level	High level	Low level	Low level	Low level	Low level	Low level	Low level
PCR5	0	0	1	1	1	1	1	1
PDR5	1	0	0	0	0	0	0	0

[BCLR instruction executed]

```
BCLR #0, @PCR5
```

The BCLR instruction is executed for PCR5.

[After executing BCLR]

	P57	P56	P55	P54	P53	P52	P51	P50
Input/output	Output	Output	Output	Output	Output	Output	Output	Input
Pin state	Low level	High level	Low level	Low level	Low level	Low level	Low level	High level
PCR5	1	1	1	1	1	1	1	0
PDR5	1	0	0	0	0	0	0	0

[Description on operation]

1. When the BCLR instruction is executed, first the CPU reads PCR5. Since PCR5 is a write-only register, the CPU reads a value of H'FF, even though the PCR5 value is actually H'3F.
2. Next, the CPU clears bit 0 in the read data to 0, changing the data to H'FE.
3. Finally, H'FE is written to PCR5 and BCLR instruction execution ends.

As a result of this operation, bit 0 in PCR5 becomes 0, making P50 an input port. However, bits 7 and 6 in PCR5 change to 1, so that P57 and P56 change from input pins to output pins. To prevent this problem, store a copy of the PCR5 data in a work area in memory and manipulate data of the bit in the work area, then write this data to PCR5.

[Prior to executing BCLR]

```
MOV.B #3F, R0L
MOV.B R0L, @RAM0
MOV.B R0L, @PCR5
```

The PCR5 value (H'3F) is written to a work area in memory (RAM0) as well as to PCR5.

	P57	P56	P55	P54	P53	P52	P51	P50
Input/output	Input	Input	Output	Output	Output	Output	Output	Output
Pin state	Low level	High level	Low level	Low level	Low level	Low level	Low level	Low level
PCR5	0	0	1	1	1	1	1	1
PDR5	1	0	0	0	0	0	0	0
RAM0	0	0	1	1	1	1	1	1

[BCLR instruction executed]

```
BCLR #0, @RAM0
```

The BCLR instructions executed for the PCR5 work area (RAM0).

[After executing BCLR]

```
MOV.B @RAM0, R0L
MOV.B R0L, @PCR5
```

The work area (RAM0) value is written to PCR5.

	P57	P56	P55	P54	P53	P52	P51	P50
Input/output	Input	Input	Output	Output	Output	Output	Output	Output
Pin state	Low level	High level	Low level	Low level	Low level	Low level	Low level	High level
PCR5	0	0	1	1	1	1	1	0
PDR5	1	0	0	0	0	0	0	0
RAM0	0	0	1	1	1	1	1	0

Section 3 Exception Handling

Exception handling may be caused by a reset, a trap instruction (TRAPA), or interrupts.

- Reset

A reset has the highest exception priority. Exception handling starts as soon as the reset is cleared by the $\overline{\text{RES}}$ pin. The chip is also reset when the watchdog timer overflows, and exception handling starts. Exception handling is the same as exception handling by the $\overline{\text{RES}}$ pin.

- Trap Instruction

Exception handling starts when a trap instruction (TRAPA) is executed. The TRAPA instruction generates a vector address corresponding to a vector number from 0 to 3, as specified in the instruction code. Exception handling can be executed at all times in the program execution state.

- Interrupts

External interrupts other than NMI and internal interrupts other than address break are masked by the I bit in CCR, and kept masked while the I bit is set to 1. Exception handling starts when the current instruction or exception handling ends, if an interrupt request has been issued.

3.1 Exception Sources and Vector Address

Table 3.1 shows the vector addresses and priority of each exception handling. When more than one interrupt is requested, handling is performed from the interrupt with the highest priority.

Table 3.1 Exception Sources and Vector Address

Relative Module	Exception Sources	Vector Number	Vector Address	Priority
$\overline{\text{RES}}$ pin	Reset	0	H'0000 to H'0001	High
Watchdog timer				
—	Reserved for system use	1 to 6	H'0002 to H'000D	
External interrupt pin	NMI	7	H'000E to H'000F	
CPU	Trap instruction #0	8	H'0010 to H'0011	
	Trap instruction #1	9	H'0012 to H'0013	
	Trap instruction #2	10	H'0014 to H'0015	
	Trap instruction #3	11	H'0016 to H'0017	Low

Relative Module	Exception Sources	Vector Number	Vector Address	Priority
Address break	Break conditions satisfied	12	H'0018 to H'0019	
CPU	Direct transition by executing the SLEEP instruction	13	H'001A to H'001B	
External interrupt pin	IRQ0, low-voltage detection interrupt	14	H'001C to H'001D	
—	Reserved for system use	15, 16	H'001E to H'0021	
External interrupt pin	IRQ3	17	H'0022 to H'0023	
	WKP	18	H'0024 to H'0025	
—	Reserved for system use	19, 20	H'0026 to H'0029	
Timer W	Timer W input capture A/ compare match A	21	H'002A to H'002B	
	Timer W input capture B/ compare match B			
	Timer W input capture C/ compare match C			
	Timer W input capture D/ compare match D			
	Timer W overflow			
Timer V	Timer V compare match A	22	H'002C to H'002D	
	Timer V compare match B			
	Timer V overflow			
SCI3	SCI3 receive data full	23	H'002E to H'002F	
	SCI3 transmit data empty			
	SCI3 transmit end			
	SCI3 receive error			
IIC2*	IIC_2 transmit data empty	24	H'0030 to H'0031	
	IIC_2 transmit end			
	IIC_2 receive error			
A/D converter	A/D conversion end	25	H'0032 to H'0033	
—	Reserved for system use	26 to 28	H'0034 to H'0039	
Timer B1*	Timer B1 overflow	29	H'003A to H'003B	
—	Reserved for system use	30 to 33	H'003C to H'0043	
Clock switch	Clock switch (external clock to on-chip oscillator clock)	34	H'0044 to H'0045	Low

Note: * Available for the H8/36912 Group only.

3.2 Register Descriptions

Interrupts are controlled by the following registers.

- Interrupt edge select register 1 (IEGR1)
- Interrupt edge select register 2 (IEGR2)
- Interrupt enable register 1 (IENR1)
- Interrupt enable register 2 (IENR2)
- Interrupt flag register 1 (IRR1)
- Interrupt flag register 2 (IRR2)
- Wakeup interrupt flag register (IWPR)

3.2.1 Interrupt Edge Select Register 1 (IEGR1)

IEGR1 selects the direction of an edge that generates interrupt requests of the $\overline{\text{IRQ3}}$ and $\overline{\text{IRQ0}}$ pins.

Bit	Bit Name	Initial Value	R/W	Description
7	—	0	—	Reserved This bit is always read as 0.
6 to 4	—	All 1	—	Reserved These bits are always read as 1.
3	IEG3	0	R/W	IRQ3 Edge Select 0: Falling edge of $\overline{\text{IRQ3}}$ pin input is detected 1: Rising edge of $\overline{\text{IRQ3}}$ pin input is detected
2, 1	—	All 0	—	Reserved These bits are always read as 0.
0	IEG0	0	R/W	IRQ0 Edge Select 0: Falling edge of $\overline{\text{IRQ0}}$ pin input is detected 1: Rising edge of $\overline{\text{IRQ0}}$ pin input is detected

3.2.2 Interrupt Edge Select Register 2 (IEGR2)

IEGR2 selects the direction of an edge that generates interrupt requests of the $\overline{\text{ADTRG}}$ and $\overline{\text{WKP5}}$ pins.

Bit	Bit Name	Initial Value	R/W	Description
7, 6	—	All 1	—	Reserved These bits are always read as 1.
5	WPEG5	0	R/W	WKP5 Edge Select 0: Falling edge of $\overline{\text{WKP5}}$ ($\overline{\text{ADTRG}}$) pin input is detected 1: Rising edge of $\overline{\text{WKP5}}$ ($\overline{\text{ADTRG}}$) pin input is detected
4 to 0	—	All 0	—	Reserved These bits are always read as 0.

3.2.3 Interrupt Enable Register 1 (IENR1)

IENR1 enables direct transition interrupts and external pin interrupts.

Bit	Bit Name	Initial Value	R/W	Description
7	IENDT	0	R/W	Direct Transfer Interrupt Enable When this bit is set to 1, direct transition interrupt requests are enabled.
6	—	0	—	Reserved This bit is always read as 0.
5	IENWP	0	R/W	Wakeup Interrupt Enable This bit is an enable bit of the $\overline{\text{WKP5}}$ pin. When this bit is set to 1, interrupt requests are enabled.
4	—	1	—	Reserved This bit is always read as 1.
3	IEN3	0	R/W	IRQ3 Interrupt Enable When this bit is set to 1, interrupt requests of the $\overline{\text{IRQ3}}$ pin are enabled.
2, 1	—	All 0	—	Reserved These bits are always read as 0.

Bit	Bit Name	Initial Value	R/W	Description
0	IEN0	0	R/W	IRQ0 Interrupt Enable When this bit is set to 1, interrupt requests of the $\overline{IRQ0}$ pin are enabled.

3.2.4 Interrupt Enable Register 2 (IENR2)

IENR2 enables timer B1 interrupts.

Bit	Bit Name	Initial Value	R/W	Description
7	—	0	—	Reserved This bit is always read as 0.
6	—	0	R/W	Reserved Although this bit is readable/writable, it should not be set to 1.
5	IENRB1	0	R/W	Timer B1 Interrupt Enable When this bit is set to 1, overflow interrupt requests of timer B1 are enabled.
4 to 0	—	All 1	—	Reserved These bits are always read as 1.

When disabling interrupts by clearing bits in an interrupt enable register, or when clearing bits in an interrupt flag register, always do so while interrupts are masked ($I = 1$). If the above clear operations are performed while $I = 0$, and as a result a conflict arises between the clear instruction and an interrupt request, exception handling for the interrupt will be executed after the clear instruction has been executed.

3.2.5 Interrupt Flag Register 1 (IRR1)

IRR1 is a status flag register for direct transition interrupts, and $\overline{\text{IRQ3}}$ and $\overline{\text{IRQ0}}$ interrupt requests.

Bit	Bit Name	Initial Value	R/W	Description
7	IRRDT	0	R/W	Direct Transfer Interrupt Request Flag [Setting condition] <ul style="list-style-type: none"> When a direct transfer is made by executing a SLEEP instruction while DTON in SYSCR2 is set to 1. [Clearing condition] <ul style="list-style-type: none"> When IRRDT is cleared by writing 0
6	—	0	—	Reserved This bit is always read as 0.
5, 4	—	All 1	—	Reserved These bits are always read as 1.
3	IRRI3	0	R/W	IRQ3 Interrupt Request Flag [Setting condition] <ul style="list-style-type: none"> When $\overline{\text{IRQ3}}$ pin is designated for interrupt input and the designated signal edge is detected [Clearing condition] <ul style="list-style-type: none"> When IRRI3 is cleared by writing 0
2, 1	—	All 0	—	Reserved These bits are always read as 0.
0	IRRI0	0	R/W	IRQ0 Interrupt Request Flag [Setting condition] <ul style="list-style-type: none"> When $\overline{\text{IRQ0}}$ pin is designated for interrupt input and the designated signal edge is detected [Clearing condition] <ul style="list-style-type: none"> When IRRI0 is cleared by writing 0

3.2.6 Interrupt Flag Register 2 (IRR2)

IRR2 is a status flag register for timer B1 interrupt requests.

Bit	Bit Name	Initial Value	R/W	Description
7	—	0	—	Reserved This bit is always read as 0.
6	—	—	—	Reserved
5	IRRTB1	0	R/W	Timer B1 Interrupt Request Flag [Setting condition] <ul style="list-style-type: none"> When timer B1 overflows [Clearing condition] <ul style="list-style-type: none"> When IRRTB1 is cleared by writing 0
4 to 0	—	All 1	—	Reserved These bits are always read as 1.

3.2.7 Wakeup Interrupt Flag Register (IWPR)

IWPR is a status flag register for $\overline{\text{WKP5}}$ interrupt requests.

Bit	Bit Name	Initial Value	R/W	Description
7, 6	—	All 1	—	Reserved These bits are always read as 1.
5	IWPF5	0	R/W	WKP5 Interrupt Request Flag [Setting condition] <ul style="list-style-type: none"> When $\overline{\text{WKP5}}$ pin is designated for interrupt input and the designated signal edge is detected. [Clearing condition] <ul style="list-style-type: none"> When IWPF5 is cleared by writing 0
4 to 0	—	All 0	—	Reserved These bits are always read as 0.

3.3 Reset Exception Handling

When the $\overline{\text{RES}}$ pin goes low, all processing halts and this LSI enters the reset. The internal state of the CPU and the registers of the on-chip peripheral modules are initialized by the reset. To ensure that this LSI is reset at power-up, hold the $\overline{\text{RES}}$ pin low for the specified period. To reset the chip during operation, hold the $\overline{\text{RES}}$ pin low for the specified period. For details, refer to section 17, Band-Gap Circuit, Power-On Reset, and Low-Voltage Detection Circuits. When the $\overline{\text{RES}}$ pin goes high after being held low for a certain period, this LSI starts reset exception handling. The reset exception handling sequence is shown in figure 3.1.

The reset exception handling sequence is as follows.

1. Set the I bit in the condition code register (CCR) to 1.
2. The CPU generates a reset exception handling vector address (from H'0000 to H'0001), the data in that address is sent to the program counter (PC) as the start address, and program execution starts from that address.

3.4 Interrupt Exception Handling

3.4.1 External Interrupts

As external interrupts, there are NMI, IRQ3, IRQ0, and WKP5 interrupts.

(1) NMI Interrupt

NMI interrupt is requested by input falling edge to the $\overline{\text{NMI}}$ pin. NMI is the highest interrupt, and can always be accepted without depending on the I bit value in CCR.

(2) IRQ3 and IRQ0 Interrupts

IRQ3 and IRQ0 interrupts are requested by input signals to the $\overline{\text{IRQ3}}$ and $\overline{\text{IRQ0}}$ pins. These interrupts are given different vector addresses, and are detected individually by either rising edge sensing or falling edge sensing, depending on the settings of the IEG3 and IEG0 bits in IEGR1.

When the $\overline{\text{IRQ3}}$ and $\overline{\text{IRQ0}}$ pins are designated for interrupt input in PMR1 and the designated signal edge is input, the corresponding bit in IRR1 is set to 1, requesting the CPU of an interrupt. These interrupts can be masked by setting the IEN3 and IEN0 bits in IENR1.

(3) WKP Interrupt

WKP interrupt is requested by an input signal to the $\overline{\text{WKP5}}$ pin. This interrupt is detected by either rising edge sensing or falling edge sensing, depending on the setting of the WPEG5 bit in IEGR2.

When the $\overline{\text{WKP5}}$ pin is designated for interrupt input in PMR5 and the designated signal edge is input, the corresponding bit in IWPR is set to 1, requesting the CPU of an interrupt. This interrupt can be masked by setting the IENWP bit in IENR1.

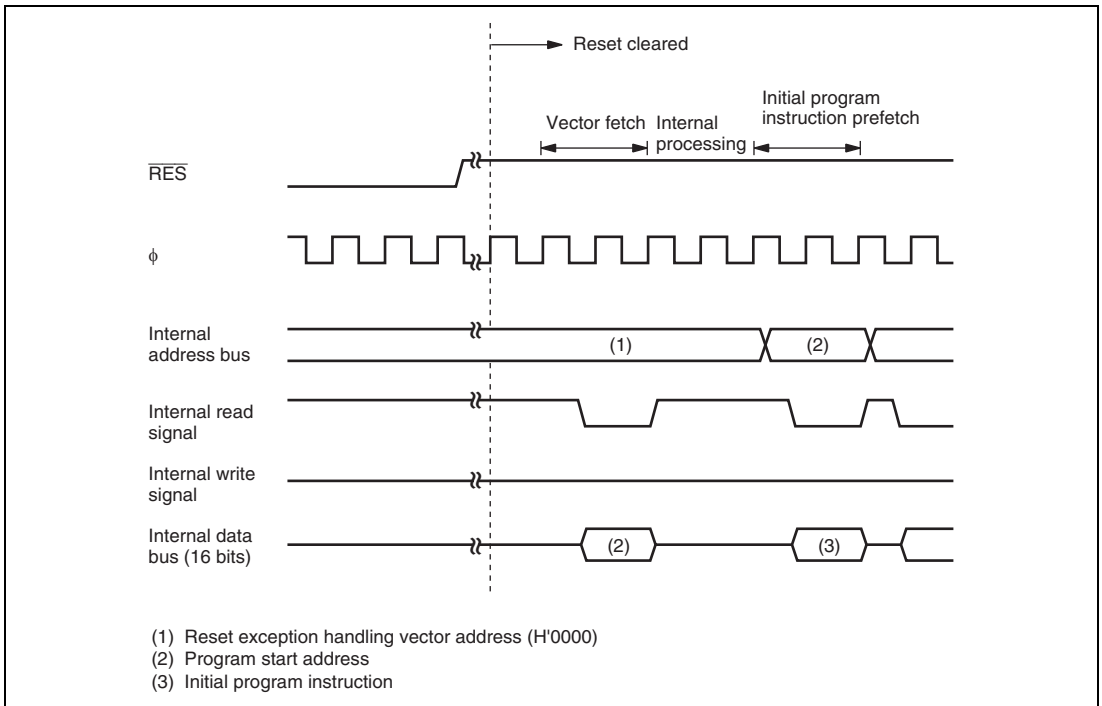

Figure 3.1 Reset Sequence

3.4.2 Internal Interrupts

Each on-chip peripheral module has a flag to show the interrupt request status and the enable bit to enable or disable the interrupt. For direct transfer interrupt requests generated by execution of a SLEEP instruction, this function is included in IRR1 and IENR1.

When an on-chip peripheral module requests an interrupt, the corresponding interrupt request status flag is set to 1, requesting the CPU of an interrupt. When this interrupt is accepted, the I bit is set to 1 in CCR. These interrupts can be masked by writing 0 to clear the corresponding enable bit.

3.4.3 Interrupt Handling Sequence

Interrupts are controlled by an interrupt controller.

Interrupt operation is described as follows.

1. If an interrupt occurs while the NMI or interrupt enable bit is set to 1, an interrupt request signal is sent to the interrupt controller.
2. When multiple interrupt requests are generated, the interrupt controller requests to the CPU for the interrupt handling with the highest priority at that time according to table 3.1. Other interrupt requests are held pending.
3. The CPU accepts the NMI or address break without depending on the I bit value. Other interrupt requests are accepted, if the I bit is cleared to 0 in CCR; if the I bit is set to 1, the interrupt request is held pending.
4. If the CPU accepts the interrupt after processing of the current instruction is completed, interrupt exception handling will begin. First, both PC and CCR are pushed onto the stack. The state of the stack at this time is shown in figure 3.2. The PC value pushed onto the stack is the address of the first instruction to be executed upon return from interrupt handling.
5. Then, the I bit of CCR is set to 1, masking further interrupts excluding the NMI and address break. Upon return from interrupt handling, the values of I bit and other bits in CCR will be restored and returned to the values prior to the start of interrupt exception handling.
6. Next, the CPU generates the vector address corresponding to the accepted interrupt, and transfers the address to PC as a start address of the interrupt handling-routine. Then a program starts executing from the address indicated in PC.

Figure 3.3 shows a typical interrupt sequence where the program area is in the on-chip ROM and the stack area is in the on-chip RAM.

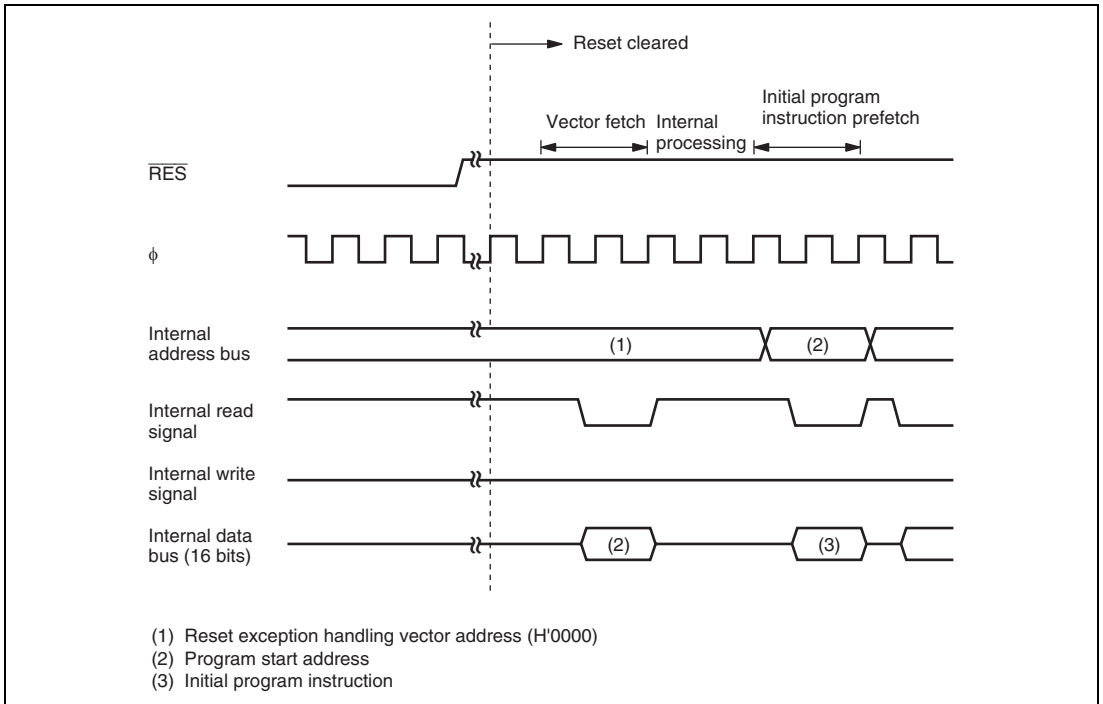

Figure 3.2 Stack Status after Exception Handling

3.4.4 Interrupt Response Time

Table 3.2 shows the number of wait states after an interrupt request flag is set until the first instruction of the interrupt handling-routine is executed.

Table 3.2 Interrupt Wait States

Item	States	Total
Waiting time for completion of executing instruction*	1 to 23	15 to 37
Saving of PC and CCR to stack	4	
Vector fetch	2	
Instruction fetch	4	
Internal processing	4	

Note: * EEPMOV instruction is not included.

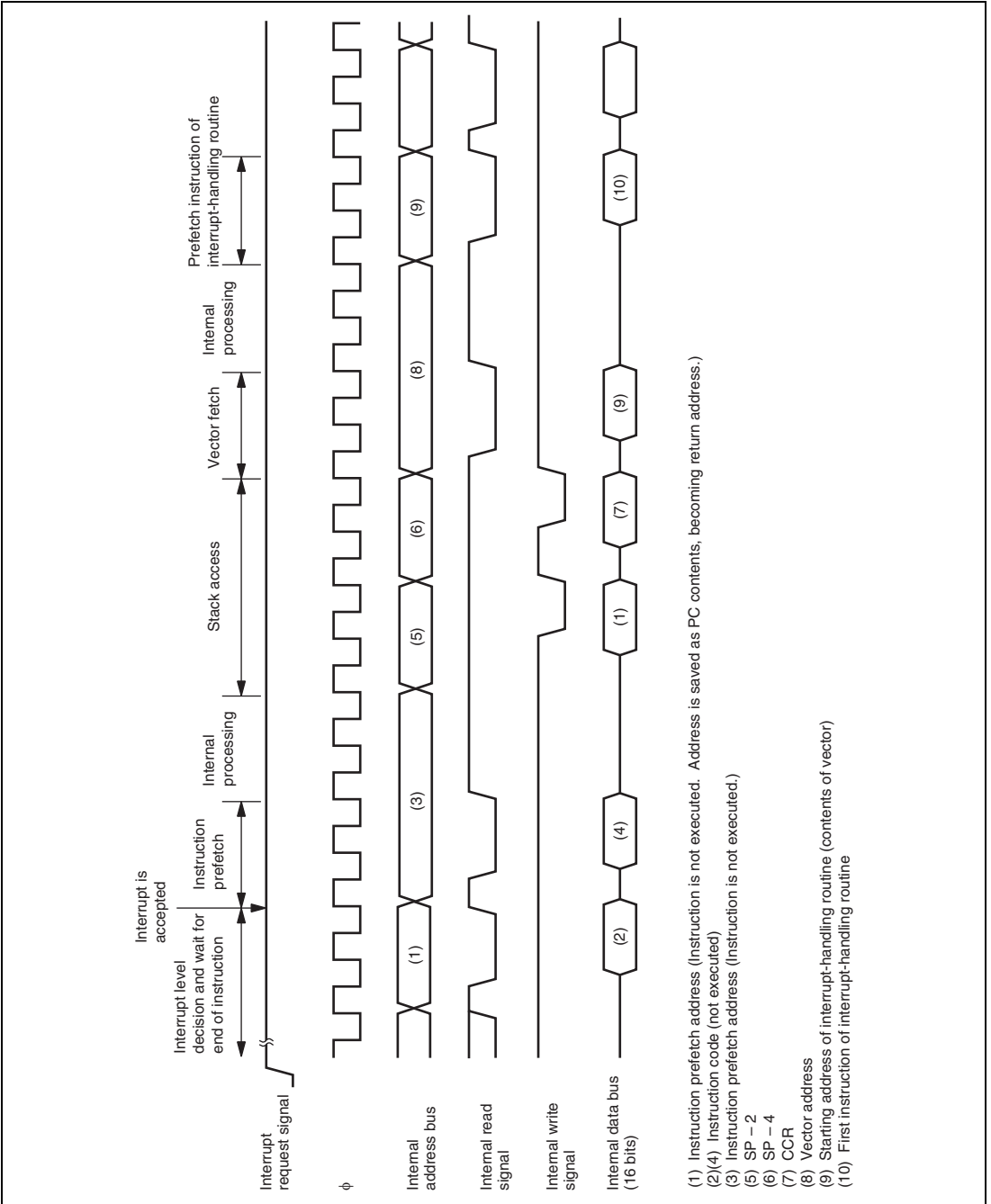

Figure 3.3 Interrupt Sequence

3.5 Usage Notes

3.5.1 Interrupts after Reset

If an interrupt is accepted after a reset and before the stack pointer (SP) is initialized, the PC and CCR will not be saved correctly, leading to a program crash. To prevent this, all interrupt requests, including NMI, are disabled immediately after a reset. Since the first instruction of a program is always executed immediately after the reset state ends, make sure that this instruction initializes the stack pointer (example: MOV.W #xx, SP).

3.5.2 Notes on Stack Area Use

When word data is accessed, the least significant bit of the address is regarded as 0. Access to the stack always takes place in word size, so the stack pointer (SP: R7) should never indicate an odd address. Use PUSH Rn (MOV.W Rn, @-SP) or POP Rn (MOV.W @SP+, Rn) to save or restore register values.

3.5.3 Notes on Rewriting Port Mode Registers

When a port mode register is rewritten to switch the functions of external interrupt pins, $\overline{\text{IRQ3}}$, $\overline{\text{IRQ0}}$, and $\overline{\text{WKP5}}$, the interrupt request flag may be set to 1.

When switching a pin function, mask the interrupt before setting the bit in the port mode register. After accessing the port mode register, execute at least one instruction (e.g., NOP), then clear the interrupt request flag from 1 to 0.

Figure 3.4 shows a port mode register setting and interrupt request flag clearing procedure.

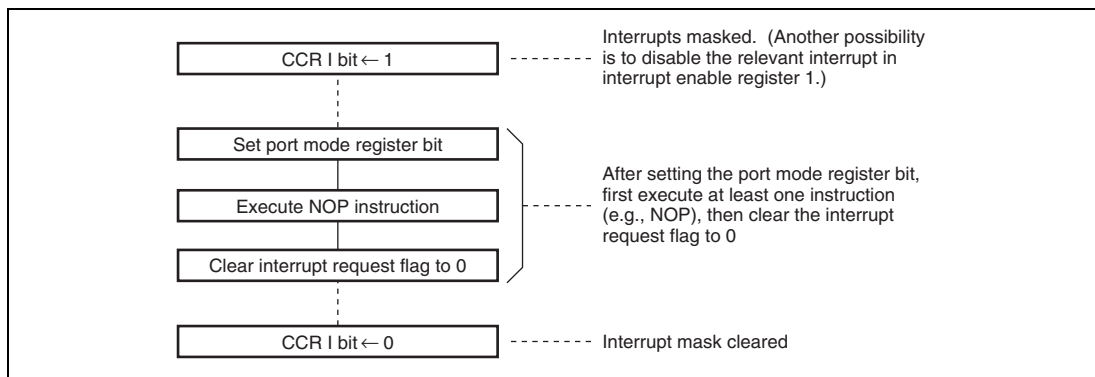

Figure 3.4 Port Mode Register Setting and Interrupt Request Flag Clearing Procedure

Section 4 Address Break

The address break simplifies on-board program debugging. It requests an address break interrupt when the set break condition is satisfied. The interrupt request is not affected by the I bit of CCR. Break conditions that can be set include instruction execution at a specific address and a combination of access and data at a specific address. With the address break function, the execution start point of a program containing a bug is detected and execution is branched to the correcting program. Figure 4.1 shows a block diagram of the address break.

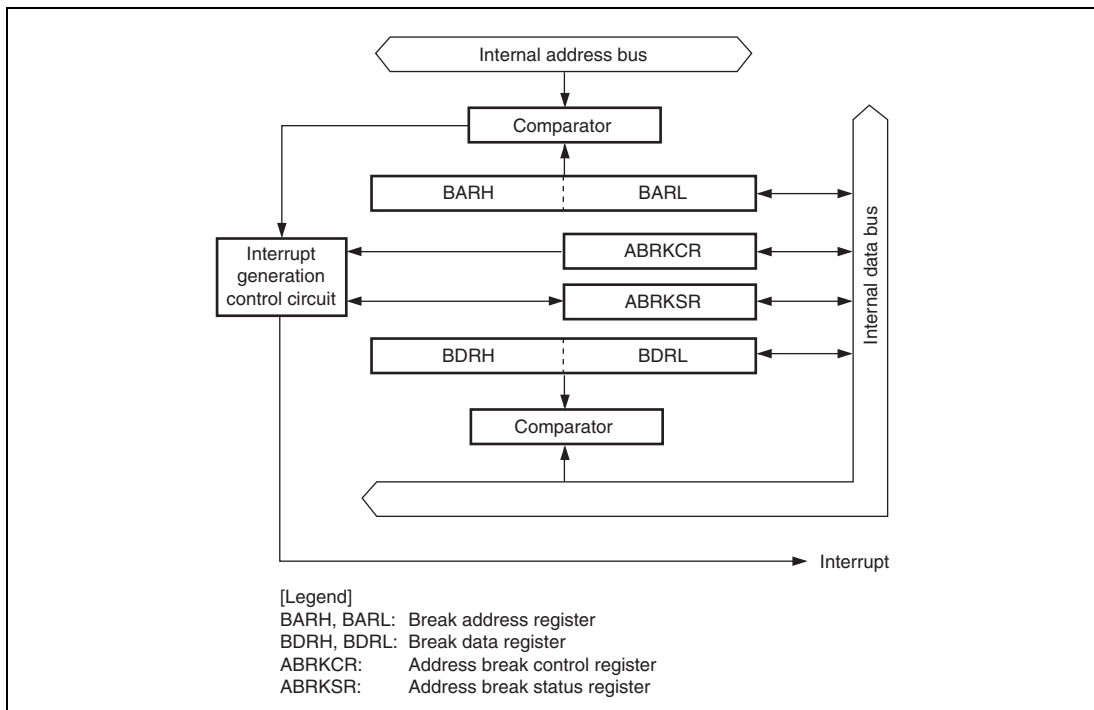

Figure 4.1 Block Diagram of Address Break

4.1 Register Descriptions

Address break has the following registers.

- Address break control register (ABRKCR)
- Address break status register (ABRKSR)
- Break address register (BARH, BARL)
- Break data register (BDRH, BDRL)

4.1.1 Address Break Control Register (ABRKCR)

ABRKCR sets address break conditions.

Bit	Bit Name	Initial Value	R/W	Description
7	RTINTE	1	R/W	RTE Interrupt Enable When this bit is 0, the interrupt immediately after executing RTE is masked and then one instruction must be executed. When this bit is 1, the interrupt is not masked.
6	CSEL1	0	R/W	Condition Select 1 and 0
5	CSEL0	0	R/W	These bits set address break conditions. 00: Instruction execution cycle 01: CPU data read cycle 10: CPU data write cycle 11: CPU data read/write cycle
4	ACMP2	0	R/W	Address Compare Condition Select 2 to 0
3	ACMP1	0	R/W	These bits comparison condition between the address set in BAR and the internal address bus.
2	ACMP0	0	R/W	000: Compares 16-bit addresses 001: Compares upper 12-bit addresses 010: Compares upper 8-bit addresses 011: Compares upper 4-bit addresses 1XX: Reserved (setting prohibited)

Bit	Bit Name	Initial Value	R/W	Description
1	DCMP1	0	R/W	Data Compare Condition Select 1 and 0
0	DCMP0	0	R/W	These bits set the comparison condition between the data set in BDR and the internal data bus. 00: No data comparison 01: Compares lower 8-bit data between BDRL and data bus 10: Compares upper 8-bit data between BDRH and data bus 11: Compares 16-bit data between BDR and data bus

[Legend]

X: Don't care

When an address break is set in the data read cycle or data write cycle, the data bus used will depend on the combination of the byte/word access and address. Table 4.1 shows the access and data bus used. When an I/O register space with an 8-bit data bus width is accessed in word size, a byte access is generated twice. For details on data widths of each register, see section 19.1, Register Addresses (Address Order).

Table 4.1 Access and Data Bus Used

	Word Access		Byte Access	
	Even Address	Odd Address	Even Address	Odd Address
ROM space	Upper 8 bits	Lower 8 bits	Upper 8 bits	Upper 8 bits
RAM space	Upper 8 bits	Lower 8 bits	Upper 8 bits	Upper 8 bits
I/O register with 8-bit data bus width	Upper 8 bits	Upper 8 bits	Upper 8 bits	Upper 8 bits
I/O register with 16-bit data bus width	Upper 8 bits	Lower 8 bits	—	—

4.1.2 Address Break Status Register (ABRKSR)

ABRKSR consists of the address break interrupt flag and the address break interrupt enable bit.

Bit	Bit Name	Initial Value	R/W	Description
7	ABIF	0	R/W	Address Break Interrupt Flag [Setting condition] <ul style="list-style-type: none"> When the condition set in ABRKCR is satisfied [Clearing condition] <ul style="list-style-type: none"> When 0 is written after ABIF=1 is read
6	ABIE	0	R/W	Address Break Interrupt Enable When this bit is 1, an address break interrupt request is enabled.
5 to 0	—	All 1	—	Reserved These bits are always read as 1.

4.1.3 Break Address Registers (BARH, BARL)

BARH and BARL are 16-bit read/write registers that set the address for generating an address break interrupt. When setting the address break condition to the instruction execution cycle, set the first byte address of the instruction. The initial value of this register is H'FFFF.

4.1.4 Break Data Registers (BDRH, BDRL)

BDRH and BDRL are 16-bit read/write registers that set the data for generating an address break interrupt. BDRH is compared with the upper 8-bit data bus. BDRL is compared with the lower 8-bit data bus. When memory or registers are accessed by byte, the upper 8-bit data bus is used for even and odd addresses in the data transmission. Therefore, comparison data must be set in BDRH for byte access. For word access, the data bus used depends on the address. See section 4.1.1, Address Break Control Register (ABRKCR), for details. The initial value of this register is undefined.

4.2 Operation

When the ABIF and ABIE bits in ABRKSR are set to 1, the address break function generates an interrupt request to the CPU. The ABIF bit in ABRKSR is set to 1 by the combination of the address set in BAR, the data set in BDR, and the conditions set in ABRKCR. When the interrupt request is accepted, interrupt exception handling starts after the instruction being executed ends. The address break interrupt is not masked because of the I bit in CCR of the CPU.

The following figures show the operation examples of the address break interrupt setting.

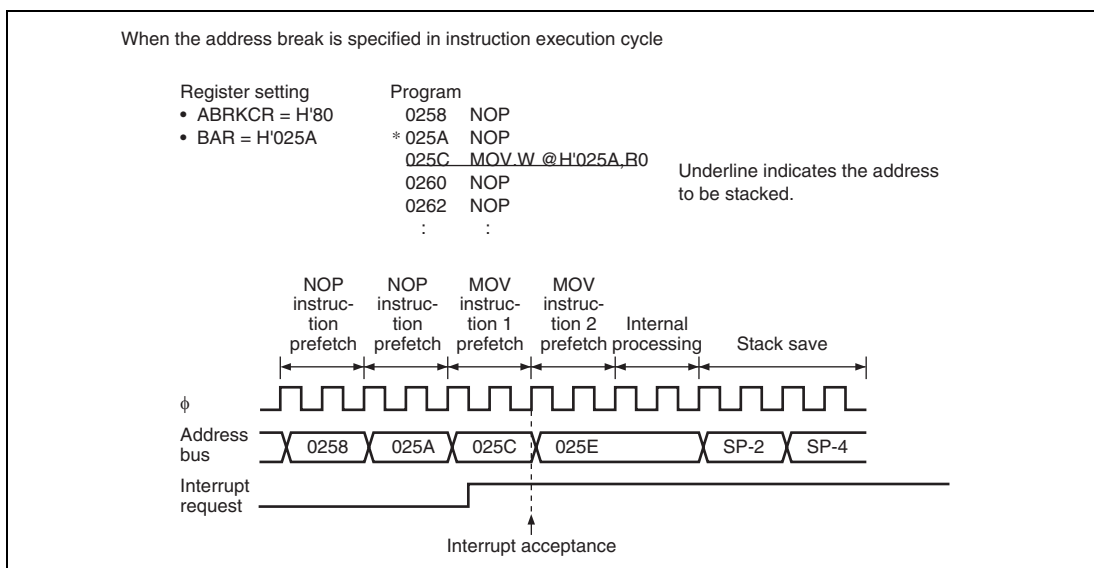

Figure 4.2 Address Break Interrupt Operation Example (1)

When the address break is specified in the data read cycle

Register setting	Program	
• ABRKCR = H'A0	0258	NOP
• BAR = H'025A	025A	NOP
	* 025C	MOV.W @H'025A,R0
	0260	NOP
	<u>0262</u>	<u>NOP</u>
	:	:

Underline indicates the address to be stacked.

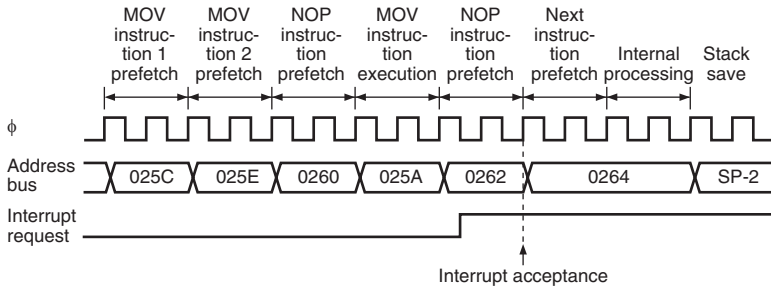

Figure 4.2 Address Break Interrupt Operation Example (2)

Section 5 Clock Pulse Generators

Clock oscillator circuitry (CPG: clock pulse generator) consists of an external oscillator, an on-chip oscillator, a duty correction circuit, a clock select circuit, and system clock dividers.

Figure 5.1 shows a block diagram of the clock pulse generator.

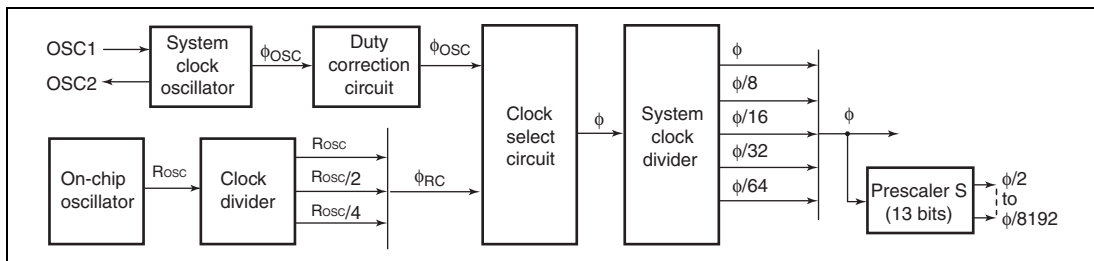

Figure 5.1 Block Diagram of Clock Pulse Generators

The system clock (ϕ) is a basic clock on which the CPU and on-chip peripheral modules operate. The system clock is divided into $\phi/2$ to $\phi/8192$ by prescaler S and the divided clocks are supplied to respective peripheral modules.

5.1 Features

- Choice of two clock sources
 - On-chip oscillator clock
 - External oscillator clock
- Choice of two types of on-chip oscillation frequency by the user software
 - 8MHz
 - 10MHz
- Frequency trimming
 - Users can adjust the on-chip oscillation frequency by rewriting the trimming registers.
- Interrupt can be requested to the CPU when the system clock is changed from the external clock to the on-chip oscillator clock.

5.2 Register Descriptions

Clock oscillators are controlled by the following registers.

- RC control register (RCCR)
- RC trimming data protect register (RCTRMDPR)
- RC trimming data register (RCTRMDR)
- Clock control/status register (CKCSR)

5.2.1 RC Control Register (RCCR)

RCCR controls the on-chip oscillator.

Bit	Bit Name	Initial Value	R/W	Description
7	RCSTP	0	R/W	On-chip Oscillator Standby The internal on-chip oscillator standby state is entered by setting this bit to 1.
6	FSEL	0	R/W	Frequency Select for On-chip Oscillator 0: 8MHz 1: 10MHz
5	VCLSEL	0	R/W	Power Supply Select for On-chip Oscillator 0: Selects VBGR 1: Selects VCL When VCL is selected, the accuracy of the on-chip oscillator frequency cannot be guaranteed.
4 to 2	—	All 0	—	Reserved These bits are always read as 0.
1	RCPSC1	0	R/W	Division Ratio Select for On-chip Oscillator
0	RCPSC0	0	R/W	The division ratio of R_{osc} changes right after rewriting this bit. These bits can be written to only when the CKSTA bit in CKCSR is 0. 0X: R_{osc} (not divided) 10: $R_{osc}/2$ 11: $R_{osc}/4$

5.2.2 RC Trimming Data Protect Register (RCTRMDPR)

RCTRMDPR controls RCTRMDPR itself and writing to RCTRMDR. Use the MOV instruction to rewrite this register. Bit manipulation instruction cannot change the settings.

Bit	Bit Name	Initial Value	R/W	Description
7	WRI	1	W	Write Inhibit Only when writing 0 to this bit, this register can be written to. This bit is always read as 1.
6	PRWE	0	R/W	Protect Information Write Enable Bits 5 and 4 can be written to when this bit is set to 1. [Setting condition] <ul style="list-style-type: none"> When writing 0 to the WRI bit and writing 1 to the PRWE bit [Clearing conditions] <ul style="list-style-type: none"> Reset When writing 0 to the WRI bit and writing 0 to the PRWE bit
5	LOCKDW	0	R/W	Trimming Data Register Lock Down The RC trimming data register (RCTRMDR) cannot be written to when this bit is set to 1. Once this bit is set to 1, this register cannot be written to until a reset is input even if 0 is written to this bit. [Setting condition] <ul style="list-style-type: none"> When writing 0 to the WRI bit and writing 1 to the LOCKDW bit while the PRWE bit is 1 [Clearing condition] <ul style="list-style-type: none"> Reset

Bit	Bit Name	Initial Value	R/W	Description
4	TRMDRWE	0	R/W	Trimming Date Register Write Enable This register can be written to when the LOCKDW bit is 0 and this bit is 1. [Setting condition] <ul style="list-style-type: none"> When writing 0 to the WRI bit while writing 1 to the TRMDRWE bit while the PRWE bit is 1 [Clearing conditions] <ul style="list-style-type: none"> Reset When writing 0 to the WRI bit and writing 0 to the TRMDRWE bit while the PRWE bit is 1
3 to 0	—	All 1	—	Reserved These bits are always read as 1

5.2.3 RC Trimming Data Register (RCTRMDR)

RCTRMDR stores the trimming data of the on-chip oscillator frequency.

Bit	Bit Name	Initial Value	R/W	Description
7	TRMD7	(0)*	R/W	Trimming Data
6	TRMD6	(0)*	R/W	In the flash memory version, the trimming data is loaded from the flash memory to this register right after a reset. These bits are always read as undefined value.
5	TRMD5	(0)*	R/W	
4	TRMD4	(0)*	R/W	
3	TRMD3	(0)*	R/W	As for the masked ROM version, the on-chip oscillator frequency can be trimmed by rewriting these bits. The frequency generated in the on-chip oscillator changes right after rewriting these bits. These bits are initialized to H'00.
2	TRMD2	(0)*	R/W	
1	TRMD1	0	R	
0	TRMD0	0	R	Frequency variation is expressed as follows (the TRMD7 bit is a sign bit): (Min.) H'80 ← H'FC ← H'00 → H'04 → H'7C (Max.)

Note: * The initial value differs from product to product in the flash memory version.

5.2.4 Clock Control/Status Register (CKCSR)

CKCSR selects the port C function, controls switching the system clocks, and indicates the system clock state.

Bit	Bit Name	Initial Value	R/W	Description
7	PMRC1	0	R/W	Port C Function Select 1 and 0
6	PMRC0	0	R/W	PMRC1 PMRC0 PC1 PC0 0 0 I/O I/O 1 0 CLKOUT I/O 0 1 I/O OSC1 (external clock input) 1 1 OSC2 OSC1
5	—	0	R/W	Reserved Although this bit is readable/writable, it should not be set to 1.
4	OSCSEL	0	R/W	LSI Operation Clock Select This bit forcibly selects the system clock of this LSI. 0: Selects the on-chip oscillator clock as the system clock. 1: Selects the external clock as the system clock.
3	CKSWIE	0	R/W	Clock Switch Interrupt Enable Setting this bit to 1 enables the clock switch interrupt request.
2	CKSWIF	0	R/W	Clock Switch Interrupt Request Flag [Setting condition] <ul style="list-style-type: none"> When the external clock is switched to the on-chip oscillator clock [Clearing condition] <ul style="list-style-type: none"> When writing 0 after reading 1
1	—	1	R	Reserved This bit is always read as 1.
0	CKSTA	0	R	LSI Operating Clock Status 0: This LSI operates on on-chip oscillator clock. 1: This LSI operates on external clock.

5.3 System Clock Select Operation

Figure 5.2 shows the state transition of the system clock.

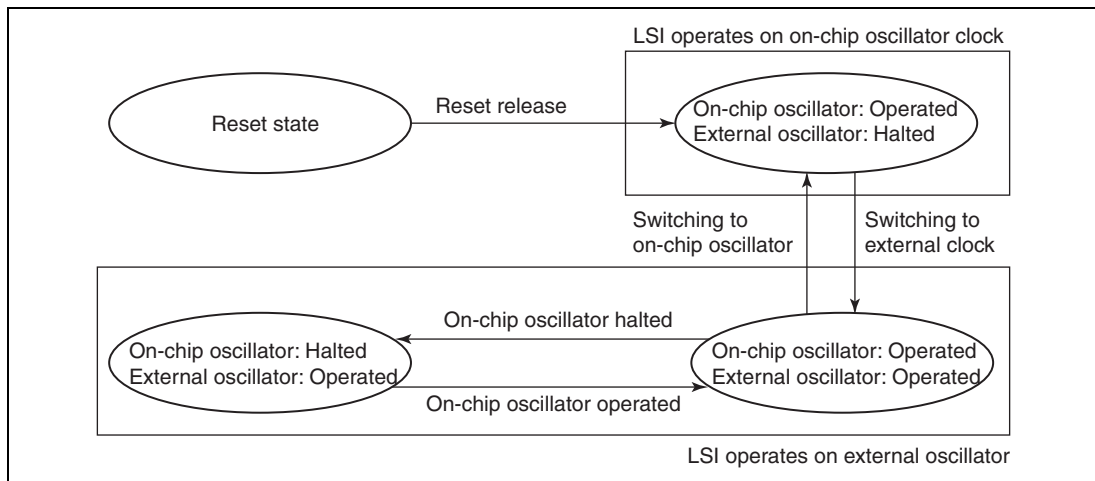

Figure 5.2 State Transition of System Clock

5.3.1 Clock Control Operation

The LSI system clock is generated by the on-chip oscillator clock after a reset. The on-chip oscillator clock is switched to the external clock by the user software.

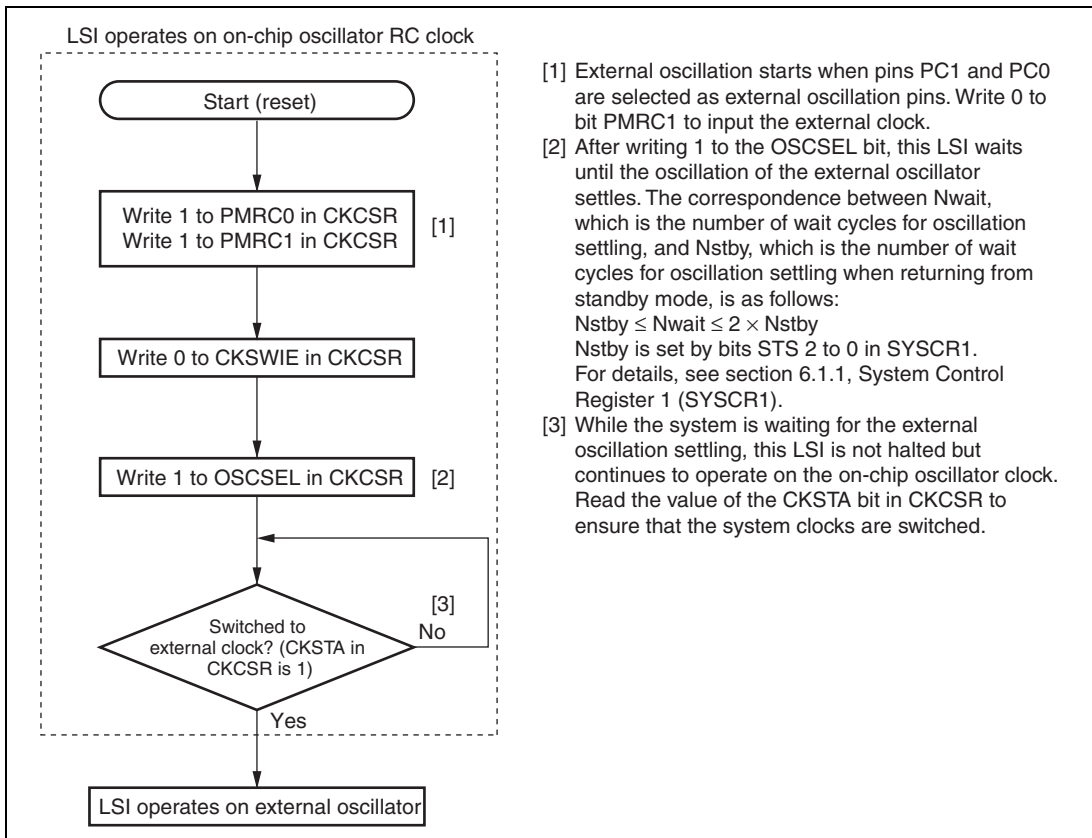
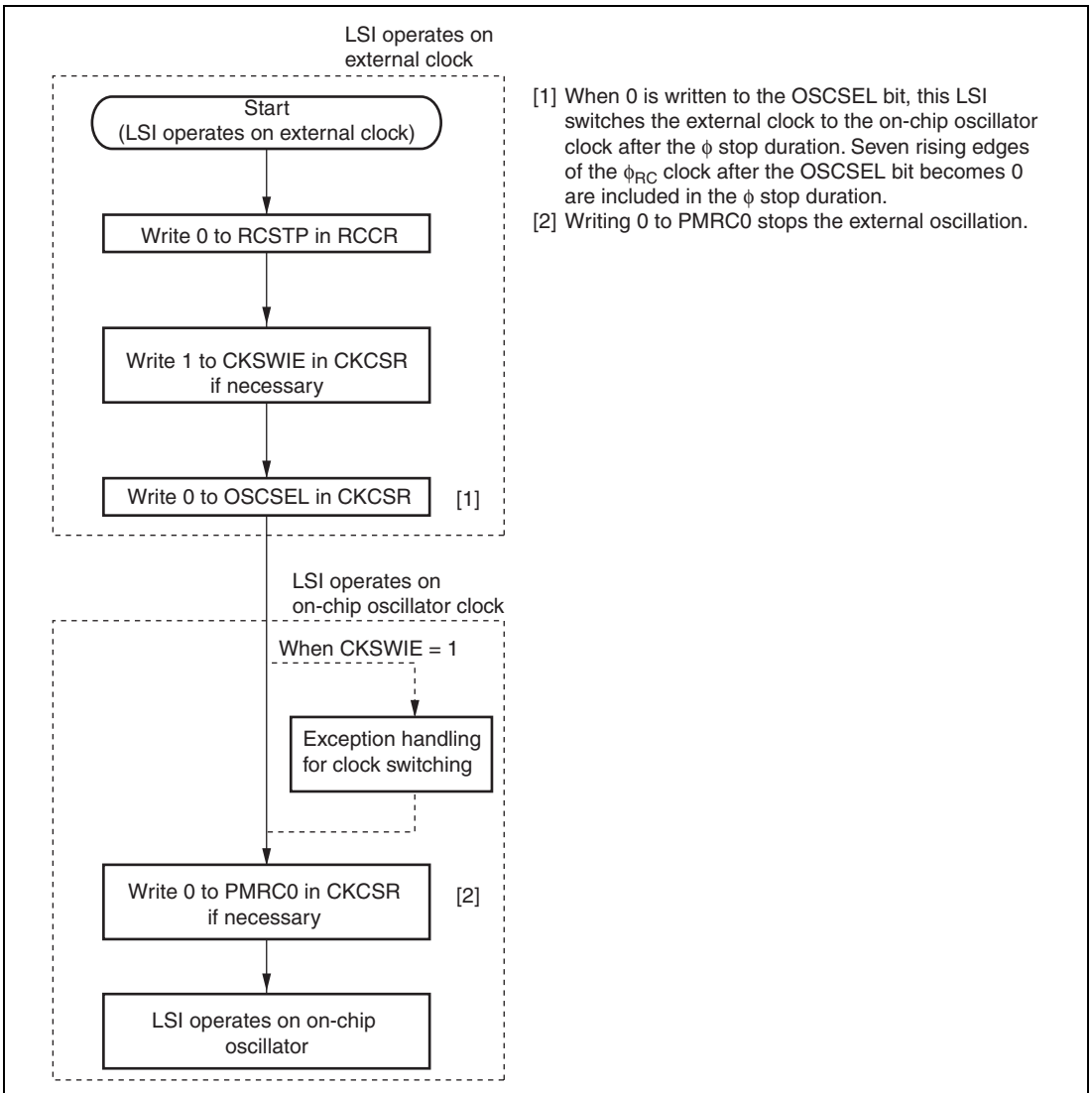

Figure 5.3 Flowchart of Clock Switching On-chip Oscillator Clock to External Clock (1)



**Figure 5.4 Flowchart of Clock Switching External
Clock to On-chip Oscillator Clock (2)**

5.3.2 Clock Change Timing

The timing for changing clocks are shown in figures 5.5 and 5.6.

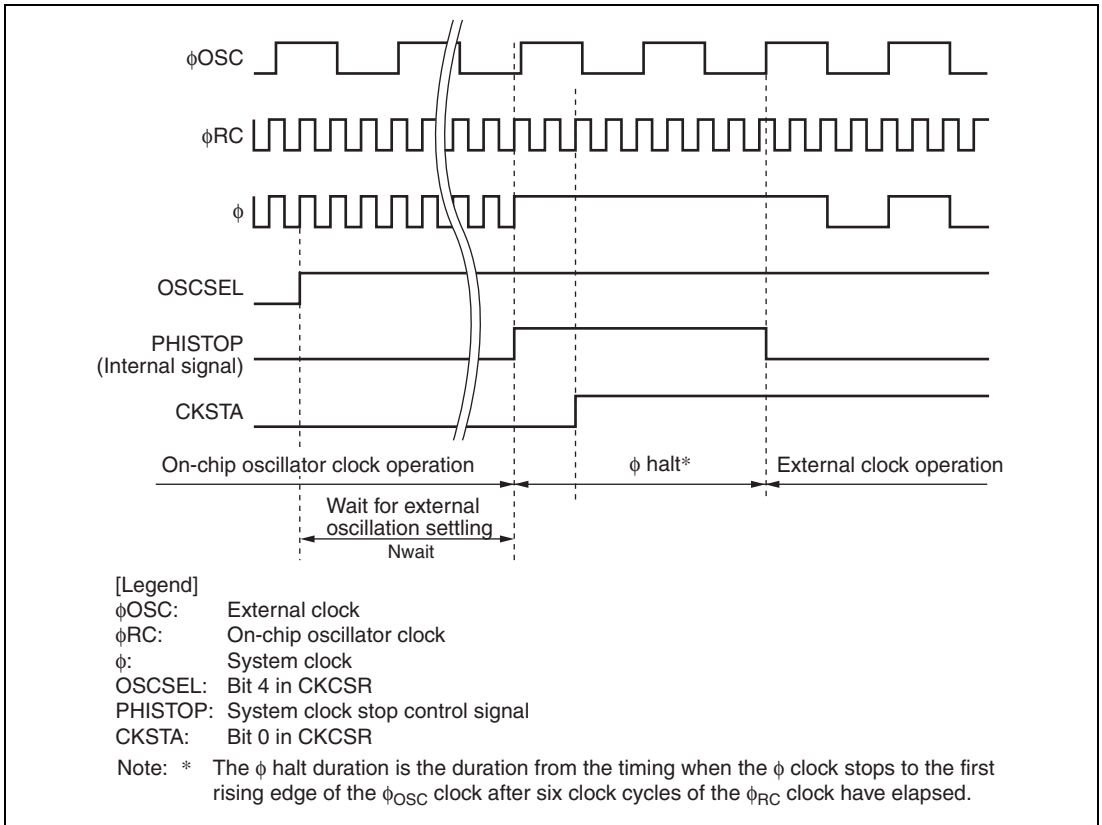

Figure 5.5 Timing Chart of Switching On-chip Oscillator Clock to External Clock

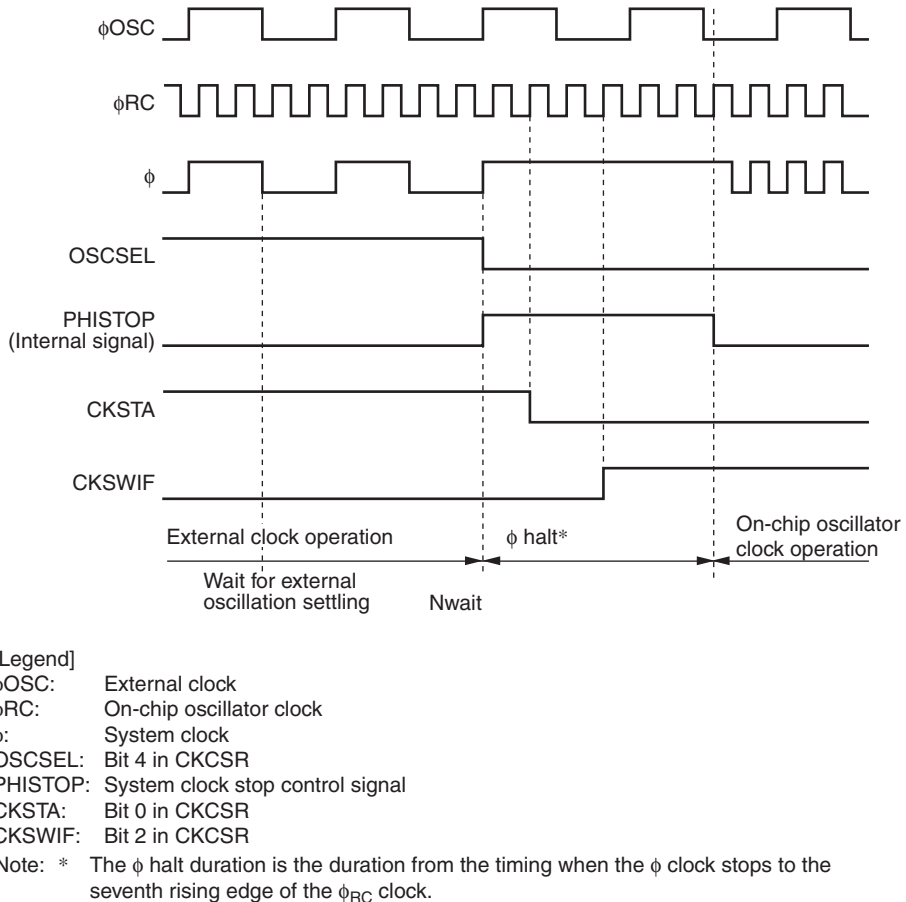

Figure 5.6 Timing Chart to Switch External Clock to On-chip Oscillator Clock

5.4 Trimming of On-chip Oscillator Frequency

Users can trim the on-chip oscillator frequency, supplying the external reference pulses with the input capture function in internal timer W. An example of trimming flow and a timing chart are shown in figures 5.7 and 5.8, respectively. Because RCTRMDR is initialized by a reset, when users have trimmed the oscillators, some operations after a reset are necessary, such as trimming it again or saving the trimming value in an external device for later reloading.

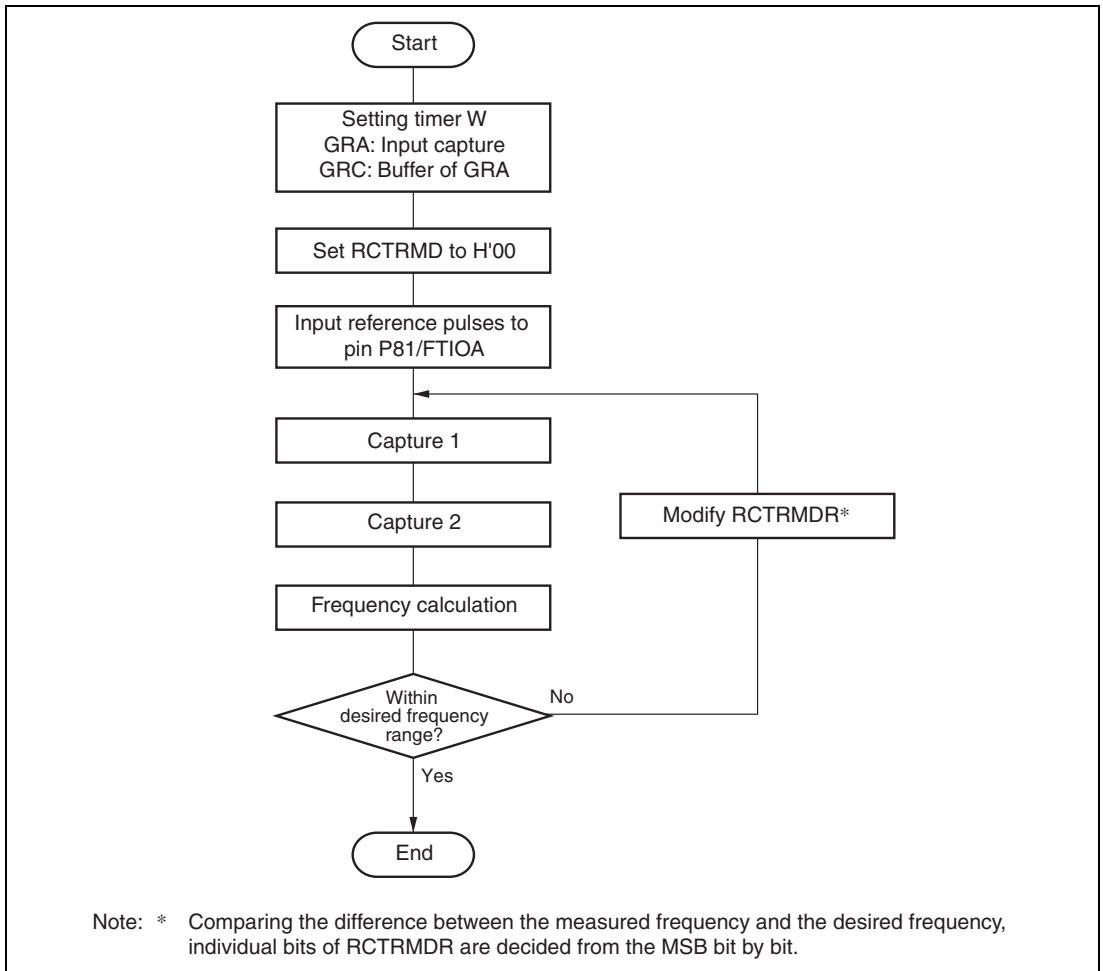

Figure 5.7 Example of Trimming Flow for On-chip Oscillator Frequency

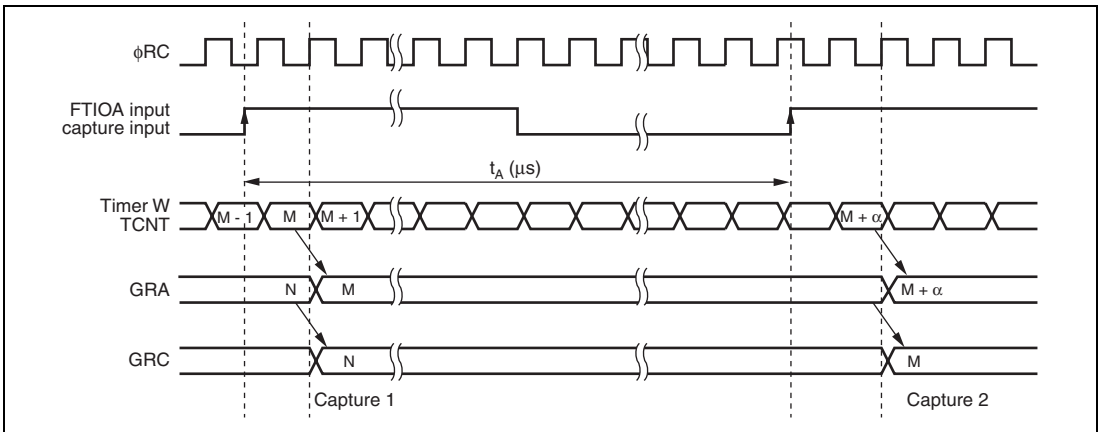

Figure 5.8 Timing Chart of Trimming of On-chip Oscillator Frequency

The on-chip oscillator frequency is gained by the expression below. Since the input-capture input is sampled by the ϕ_{RC} clock, the calculated result may include a sampling error of ± 1 cycle of the ϕ_{RC} clock.

$$\phi_{RC} = \frac{(M + \alpha) - M}{t_A} \quad (\text{MHz})$$

ϕ_{RC} : Frequency of on-chip oscillator (MHz)
 t_A : Period of reference clock (μs)
 M : Timer W counter value

5.5 External Oscillators

This LSI has two methods to supply external clock pulses into it: connecting a crystal or ceramic resonator, and an external clock. Oscillation pins OSC1 and OSC2 are common with general ports PC0 and PC1, respectively. To set pins PC0 and PC1 as crystal resonator or external clock input ports, refer to section 5.3, System Clock Select Operation.

5.5.1 Connecting Crystal Resonator

Figure 5.9 shows an example of connecting a crystal resonator. An AT-cut parallel-resonance crystal resonator should be used. Figure 5.12 shows the equivalent circuit of a crystal resonator. A resonator having the characteristics given in table 5.1 should be used.

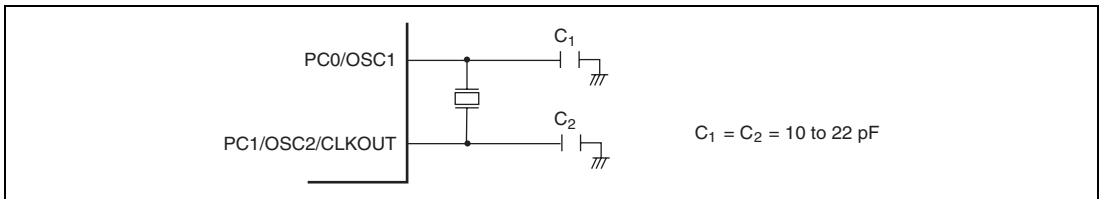

Figure 5.9 Example of Connection to Crystal Resonator

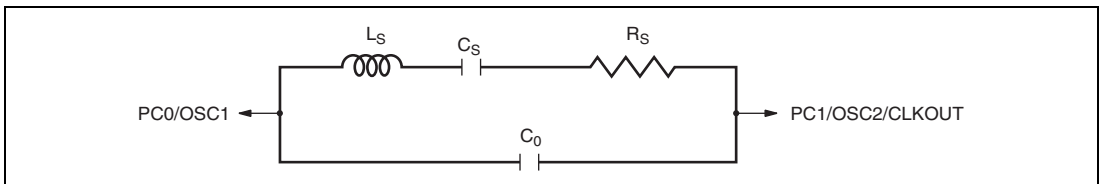

Figure 5.10 Equivalent Circuit of Crystal Resonator

Table 5.1 Crystal Resonator Parameters

Frequency (MHz)	2	4	8	10	12
R_s (Max.)	500 Ω	120 Ω	80 Ω	60 Ω	50 Ω
C_0 (Max.)	70 pF				

5.5.2 Connecting Ceramic Resonator

Figure 5.11 shows an example of connecting a ceramic resonator.

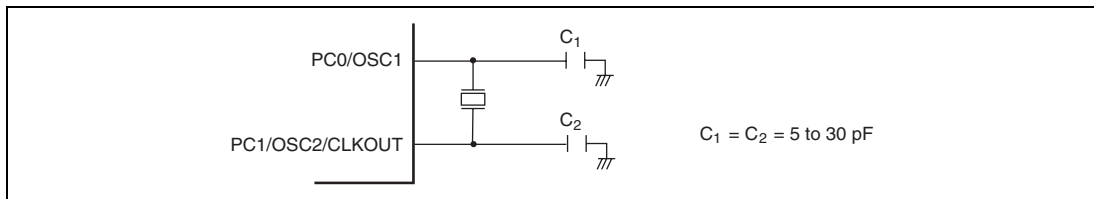

Figure 5.11 Example of Connection to Ceramic Resonator

5.5.3 External Clock Input Method

To use the external clock, input the external clock on pin OSC1. Figure 5.12 shows an example of connection. The duty cycle of the external clock signal must be 45 to 55%.

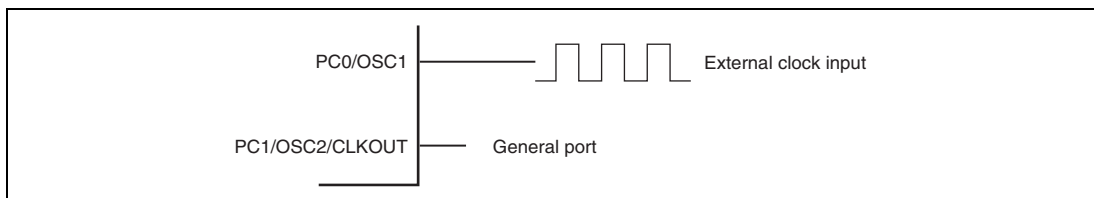

Figure 5.12 Example of External Clock Input

5.6 Prescaler

5.6.1 Prescaler S

Prescaler S is a 13-bit counter using the system clock (ϕ) as its input clock. The outputs, which are divided clocks, are used as internal clocks by the on-chip peripheral modules. Prescaler S is initialized to H'0000 by a reset, and starts counting on exit from the reset state. In standby mode and subsleep mode, the system clock pulse generator stops. Prescaler S also stops and is initialized to H'0000. It cannot be read from or written to by the CPU.

The outputs from prescaler S is shared by the on-chip peripheral modules. The division ratio can be set separately for each on-chip peripheral module. In active mode and sleep mode, the clock input to prescaler S is a system clock with the division ratio specified by bits MA2 to MA0 in SYSCR2.

5.7 Usage Notes

5.7.1 Note on Resonators

Resonator characteristics are closely related to board design and should be carefully evaluated by the user, referring to the examples shown in this section. Resonator circuit parameters will differ depending on the resonator element, stray capacitance of the PCB, and other factors. Suitable values should be determined in consultation with the resonator element manufacturer. Design the circuit so that the resonator element never receives voltages exceeding its maximum rating.

5.7.2 Notes on Board Design

When using a crystal resonator (ceramic resonator), place the resonator and its load capacitors as close as possible to pins OSC1 and OSC2. Other signal lines should be routed away from the oscillator circuit to prevent induction from interfering with correct oscillation (see figure 5.13).

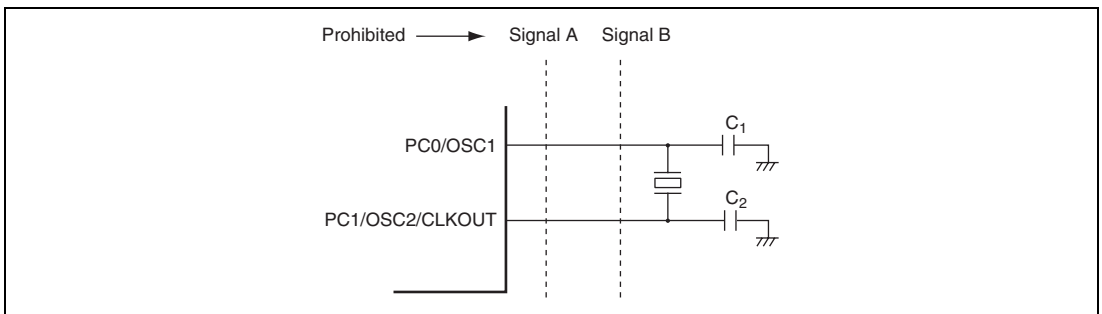

Figure 5.13 Example of Incorrect Board Design

Section 6 Power-Down Modes

For operating modes after a reset, this LSI has not only a normal active mode but also three power-down modes in which power consumption is significantly reduced. In addition, there is also a module standby function which reduces power consumption by individually stopping on-chip peripheral modules.

- Active mode

The CPU and all on-chip peripheral modules are operable on the system clock. The system clock frequency can be selected from ϕ_{osc} , $\phi_{osc}/8$, $\phi_{osc}/16$, $\phi_{osc}/32$, and $\phi_{osc}/64$.

- Sleep mode

The CPU halts. On-chip peripheral modules are operable on the system clock.

- Standby mode

The CPU and all on-chip peripheral modules halt.

- Subsleep mode

The CPU and all on-chip peripheral modules halt. I/O ports keep the same states as before the transition.

- Module standby function

Independent of the above modes, power consumption can be reduced by halting on-chip peripheral modules that are not used in module units.

6.1 Register Descriptions

The registers related to power-down modes are listed below.

- System control register 1 (SYSCR1)
- System control register 2 (SYSCR2)
- Module standby control register 1 (MSTCR1)
- Module standby control register 2 (MSTCR2)

6.1.1 System Control Register 1 (SYSCR1)

SYSCR1 controls the power-down modes, as well as SYSCR2.

Bit	Bit Name	Initial Value	R/W	Description
7	SSBY	0	R/W	<p>Software Standby</p> <p>Specifies the operating mode to be entered after executing the SLEEP instruction.</p> <p>0: Shifts to sleep mode.</p> <p>1: Shifts to standby mode.</p> <p>For details, see table 6.2.</p>
6	STS2	0	R/W	Standby Timer Select 2 to 0
5	STS1	0	R/W	<p>These bits set the wait time from when the system clock oscillator starts functioning until the clock is supplied, in shifting from standby mode, to active mode or sleep mode. During the wait time, this LSI automatically selects the on-chip oscillator clock as its system clock and counts the number of wait states. Select a wait time of 6.5 ms (oscillation stabilization time) or longer, depending on the operating frequency. Table 6.1 shows the relationship between the STS2 to STS0 values and the wait time.</p> <p>When using an external clock, set the wait time to be 100 μs or longer in the F-ZTAT version. In the masked ROM version, the minimum value (STS2 = STS1 = STS0 = 1) is recommended.</p> <p>These bits also set the wait states for external oscillation stabilization when system clock is switched from the on-chip oscillator clock to the external clock by user software.</p> <p>The relationship between Nwait (number of wait states for oscillation stabilization) and Nstby (number of wait states for recovering to the standby mode) is as follows.</p> <p>$Nstby \leq Nwait \leq 2 \times Nstby$</p>
4	STS0	0	R/W	
3 to 0	—	All 0	—	<p>Reserved</p> <p>These bits are always read as 0.</p>

Table 6.1 Operating Frequency and Wait Time

Bit Name			Wait Time	Operating Frequency					
STS2	STS1	STS0		10 MHz	8 MHz	5 MHz	4 MHz	2.5 MHz	2 MHz
0	0	0	8,192 states	0.8	1.0	1.6	2.0	3.3	4.1
0	0	1	16,384 states	1.6	2.0	3.3	4.1	6.6	8.2
0	1	0	32,768 states	3.3	4.1	6.6	8.2	13.1	16.4
0	1	1	65,536 states	6.6	8.2	13.1	16.4	26.2	32.8
1	0	0	131,072 states	13.1	16.4	26.2	32.8	52.4	65.5
1	0	1	1,024 states	0.10	0.13	0.21	0.26	0.42	0.51
1	1	0	128 states	0.01	0.02	0.03	0.03	0.05	0.06
1	1	1	16 states	0.00	0.00	0.00	0.00	0.00	0.01

Notes: 1. Time unit is ms.

2. The on-chip oscillator clock counts the wait states, even when the external clock is used as system clock.

6.1.2 System Control Register 2 (SYSCR2)

SYSCR2 controls the power-down modes, as well as SYSCR1.

Bit	Bit Name	Initial Value	R/W	Description	
7	SMSEL	0	R/W	Sleep Mode Selection This bit specifies the mode to be entered after executing the SLEEP instruction, as well as the SSBY bit in SYSCR1. For details, see table 6.2.	
6	—	0	—	Reserved This bit is always read as 0.	
5	DTON	0	R/W	Direct Transfer on Flag This bit specifies the mode to be entered after executing the SLEEP instruction, as well as the SSBY bit in SYSCR1. For details, see table 6.2.	
4	MA2	0	R/W	Active Mode Clock Select 2 to 0	
3	MA1	0	R/W	These bits select the operating clock frequency in active and sleep modes. The operating clock frequency changes to the set frequency after the SLEEP instruction is executed. 0XX: ϕ 100: $\phi/8$ 101: $\phi/16$ 110: $\phi/32$ 111: $\phi/64$	
2	MA0	0	R/W		
1, 0	—	All 0	—		
					Reserved
					These bits are always read as 0.

[Legend]

X: Don't care

6.1.3 Module Standby Control Register 1 (MSTCR1)

MSTCR1 allows the on-chip peripheral modules to enter a standby state in module units.

Bit	Bit Name	Initial Value	R/W	Description
7	—	0	—	Reserved This bit is always read as 0.
6	MSTIIC	0	R/W	IIC2 Module Standby IIC2 enters standby mode when this bit is set to 1.
5	MSTS3	0	R/W	SCI3 Module Standby SCI3 enters standby mode when this bit is set to 1.
4	MSTAD	0	R/W	A/D Converter Module Standby A/D converter enters standby mode when this bit is set to 1.
3	MSTWD	0	R/W	Watchdog Timer Module Standby Watchdog timer enters standby mode when this bit is set to 1. (When the internal oscillator is selected for the watchdog timer clock, the watchdog timer operates regardless of the setting of this bit.)
2	MSTTW	0	R/W	Timer W Module Standby Timer W enters standby mode when this bit is set to 1.
1	MSTTV	0	R/W	Timer V Module Standby Timer V enters standby mode when this bit is set to 1.
0	—	0	—	Reserved This bit is always read as 0.

6.1.4 Module Standby Control Register 2 (MSTCR2)

MSTCR2 allows the on-chip peripheral modules to enter a standby state in module units.

Bit	Bit Name	Initial Value	R/W	Description
7 to 5	—	All 0	—	Reserved These bits are always read as 0.
4	MSTTB1	0	R/W	Timer B1 Module Standby Timer B1 enters standby mode when this bit is set to 1.
3 to 0	—	All 0	—	Reserved These bits are always read as 0.

6.2 Mode Transitions and States of LSI

Figure 6.1 shows the possible transitions among these operating modes. A transition is made from the program execution state to the program halt state of the program by executing a SLEEP instruction. Interrupts allow for returning from the program halt state to the program execution state of the program. A direct transition from active mode to active mode changes the operating frequency. RES input enables transitions from a mode to the reset state. Table 6.2 shows the transition conditions of each mode after the SLEEP instruction is executed and a mode to return by an interrupt. Table 6.3 shows the internal states of the LSI in each mode.

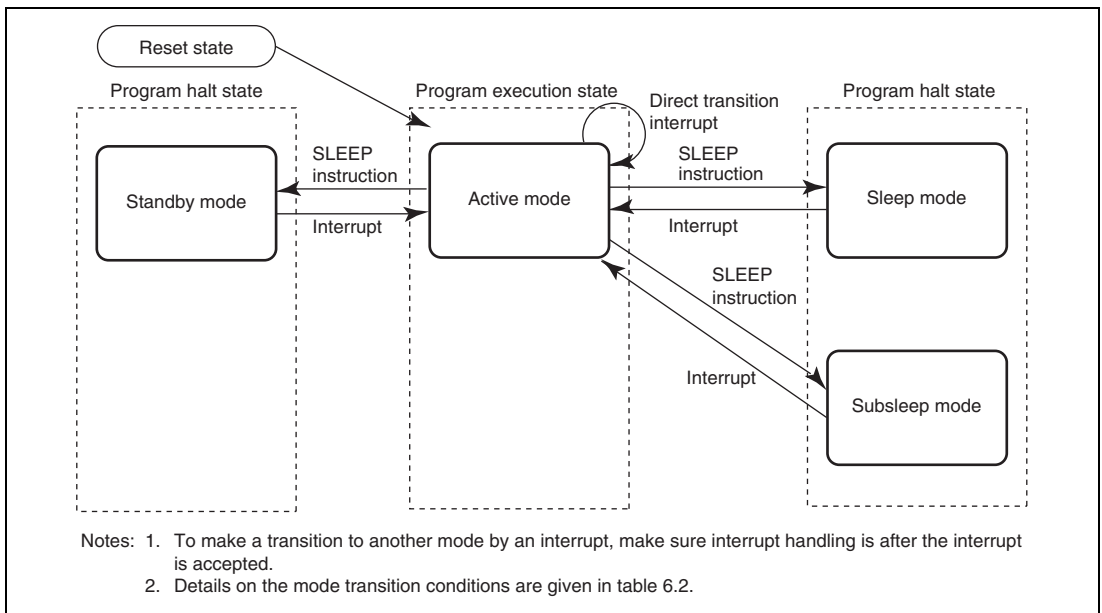

Figure 6.1 Mode Transition Diagram

Table 6.2 Transition Mode after SLEEP Instruction Execution and Interrupt Handling

DTON	SSBY	SMSEL	Transition Mode after SLEEP Instruction Execution	Transition Mode due to Interrupt
0	0	0	Sleep mode	Active mode
	0	1	Subsleep mode	Active mode
	1	X	Standby mode	Active mode
1	X	0*	Active mode (direct transition)	—

[Legend]

X: Don't care

Note: * When a state transition is performed while SMSEL is 1, timer V, SCI3, and the A/D converter are reset, and all registers are set to their initial values. To use these functions after entering active mode, reset the registers.

Table 6.3 Internal State in Each Operating Mode

Function		Active Mode	Sleep Mode	Subsleep Mode	Standby Mode
System clock oscillator		Functioning	Functioning	Halted	Halted
CPU operations	Instructions	Functioning	Halted	Halted	Halted
	Registers	Functioning	Retained	Retained	Retained
RAM		Functioning	Retained	Retained	Retained
IO ports		Functioning	Retained	Retained	Register contents are retained, but output is the high-impedance state.
External interrupts	IRQ3, IRQ0	Functioning	Functioning	Functioning	Functioning
	WKP5	Functioning	Functioning	Functioning	Functioning
Peripheral modules	Timer B1	Functioning	Functioning	Retained	Retained
	Timer V	Functioning	Functioning	Reset	Reset
	Timer W	Functioning	Functioning	Retained	Retained
	Watchdog timer	Functioning	Functioning	Retained (Functioning if the internal oscillator is selected as a count clock.)	
	SCI3	Functioning	Functioning	Reset	Reset
	IIC2	Functioning	Functioning	Retained	Retained
	A/D converter	Functioning	Functioning	Reset	Reset
	LVD	Functioning	Functioning	Functioning	Functioning

6.2.1 Sleep Mode

In sleep mode, CPU operation is halted but the on-chip peripheral modules function at the clock frequency set by the MA2 to MA0 bits in SYSCR2. CPU register contents are retained. When an interrupt is requested, sleep mode is cleared and the CPU starts interrupt exception handling. Sleep mode is not cleared if the I bit in the condition code register (CCR) is set to 1 or the requested interrupt is disabled by the interrupt enable bit. When the $\overline{\text{RES}}$ pin is driven low in sleep mode, the CPU goes into the reset state and sleep mode is cleared.

6.2.2 Standby Mode

In standby mode, the system clock oscillator is halted, and operation of the CPU and on-chip peripheral modules is halted. However, as long as the rated voltage is supplied, the contents of CPU registers, on-chip RAM, and some on-chip peripheral module registers are retained. On-chip RAM contents will be retained as long as the voltage set by the RAM data retention voltage is provided. The I/O ports go to the high-impedance state.

Standby mode is cleared by an interrupt. When an interrupt is requested, the on-chip oscillator starts functioning. The external oscillator also starts functioning when used. After the time set by the STS2 to STS0 bits in SYSCR1 has elapsed, standby mode is cleared and the CPU starts interrupt exception handling. Standby mode is not cleared if the I bit in the condition code register (CCR) is set to 1 or the requested interrupt is disabled by the interrupt enable bit.

When the $\overline{\text{RES}}$ pin is driven low in standby mode, the on-chip oscillator starts functioning. The system clock is supplied to the entire chip as soon as the on-chip oscillator starts functioning. The $\overline{\text{RES}}$ pin must be kept low for the rated period. On driving the $\overline{\text{RES}}$ pin high, after the oscillation stabilization time set by the power-on reset circuit has elapsed, the internal reset signal is cleared and the CPU starts reset exception handling.

6.2.3 Subsleep Mode

In subsleep mode, the system clock oscillator is halted, and operation of the CPU and on-chip peripheral modules is halted. However, as long as the rated voltage is supplied, the contents of CPU registers, the on-chip RAM, and some on-chip peripheral module registers are retained. The I/O ports keep the same states as before the transition.

Subsleep mode is cleared by an interrupt. When an interrupt is requested, the on-chip oscillator starts functioning. The external oscillator also starts functioning when used. After the time set by the STS2 to STS0 bits in SYSCR1 has elapsed, subsleep mode is cleared and the CPU starts interrupt exception handling. Subsleep mode is not cleared if the I bit in the condition code register (CCR) is set to 1 or the requested interrupt is disabled by the interrupt enable bit.

When the $\overline{\text{RES}}$ pin is driven low in subsleep mode, the on-chip oscillator starts functioning. The system clock is supplied to the entire chip as soon as the on-chip oscillator starts functioning. The $\overline{\text{RES}}$ pin must be kept low for the rated period. On driving the $\overline{\text{RES}}$ pin high, after the oscillation stabilization time set by the power-on reset circuit has elapsed, the internal reset signal is cleared and the CPU starts reset exception handling.

6.3 Operating Frequency in Active Mode

Operation in active mode is clocked at the frequency designated by the MA2 to MA0 bits in SYSCR2. The operating frequency changes to the set frequency after SLEEP instruction execution.

6.4 Direct Transition

The CPU can execute programs in active mode. The operating frequency can be changed by making a transition directly from active mode to active mode. A direct transition can be made by executing a SLEEP instruction while the DTON bit in SYSCR2 is set to 1. If the direct transition interrupt is disabled by the interrupt enable register 1, a transition is made instead to sleep mode or subsleep mode. Note that if a direct transition is attempted while the I bit in condition code register (CCR) is set to 1, sleep mode or subsleep mode will be entered though that mode cannot be cleared by means of an interrupt.

6.5 Module Standby Function

The module standby function can be set to any peripheral module. In module standby mode, the clock supply to the specified module stops and the module enters the power-down mode. Module standby mode enables each on-chip peripheral module to enter the standby state by setting a bit that corresponds to each module in MSTCR1 and MSTCR2 to 1 and cancels the mode by clearing the bit to 0.

Section 7 ROM

The features of the 12-kbyte (including 4 kbytes as the E7 or E8 control program area) flash memory built into the HD64F36912G and HD64F36902G are summarized below.

- Programming/erase methods
 - The flash memory is programmed in 64-byte units at a time. Erase is performed in single-block units. The flash memory is configured as follows: 1 kbyte \times 4 blocks and 4 kbytes \times 2 blocks. To erase the entire flash memory, each block must be erased in turn.
- Reprogramming capability
 - The flash memory can be reprogrammed up to 1,000 times.
- On-board programming
 - On-board programming/erasing can be done in boot mode, in which the boot program built into the chip is started to erase or program of the entire flash memory. In normal user program mode, individual blocks can be erased or programmed.
- Automatic bit rate adjustment
 - For data transfer in boot mode, this LSI's bit rate can be automatically adjusted to match the transfer bit rate of the host.
- Programming/erasing protection
 - Sets software protection against flash memory programming/erasing.

7.1 Block Configuration

Figure 7.1 shows the block configuration of 12-kbyte flash memory. The thick lines indicate erasing units, the narrow lines indicate programming units, and the values are addresses. The flash memory is divided into 1 kbyte \times 4 blocks and 4 kbytes \times 2 blocks. Erasing is performed in these units. Programming is performed in 64-byte units starting from an address with lower eight bits H'00, H'40, H'80, or H'C0.

Erase unit	H'0000	H'0001	H'0002	← Programming unit: 64 bytes →	H'003F
	H'0040	H'0041	H'0042		H'007F
1 kbyte					
Erase unit	H'03C0	H'03C1	H'03C2		H'03FF
	H'0400	H'0401	H'0402	← Programming unit: 64 bytes →	H'043F
1 kbyte					
Erase unit	H'0440	H'0441	H'0442		H'047F
Erase unit	H'07C0	H'07C1	H'07C2		H'07FF
	H'0800	H'0801	H'0802	← Programming unit: 64 bytes →	H'083F
1 kbyte					
Erase unit	H'0840	H'0841	H'0842		H'087F
Erase unit	H'0BC0	H'0BC1	H'0BC2		H'0BFF
	H'0C00	H'0C01	H'0C02	← Programming unit: 64 bytes →	H'0C3F
1 kbyte					
Erase unit	H'0C40	H'0C41	H'0C42		H'0C7F
Erase unit	H'0FC0	H'0FC1	H'0FC2		H'0FFF
	H'1000	H'1001	H'1002	← Programming unit: 64 bytes →	H'103F
4 kbytes					
Erase unit	H'1040	H'1041	H'1042		H'107F
Erase unit	H'1FC0	H'1FC1	H'1FC2		H'1FFF
	H'2000	H'2001	H'2002	← Programming unit: 64 bytes →	H'203F
4 kbytes					
Erase unit	H'2040	H'2041	H'2042		H'207F
	H'2FC0	H'2FC1	H'2FC2		H'2FFF

Figure 7.1 Flash Memory Block Configuration

7.2 Register Descriptions

The flash memory has the following registers.

- Flash memory control register 1 (FLMCR1)
- Flash memory control register 2 (FLMCR2)
- Erase block register 1 (EBR1)
- Flash memory enable register (FENR)

7.2.1 Flash Memory Control Register 1 (FLMCR1)

FLMCR1 is a register that makes the flash memory change to program mode, program-verify mode, erase mode, or erase-verify mode. For details on register setting, refer to section 7.4, Flash Memory Programming/Erasing.

Bit	Bit Name	Initial Value	R/W	Description
7	—	0	—	Reserved This bit is always read as 0.
6	SWE	0	R/W	Software Write Enable When this bit is set to 1, flash memory programming/erasing is enabled. When this bit is cleared to 0, other FLMCR1 register bits and all EBR1 bits cannot be set.
5	ESU	0	R/W	Erase Setup When this bit is set to 1, the flash memory changes to the erase setup state. When it is cleared to 0, the erase setup state is cancelled. Set this bit to 1 before setting the E bit to 1 in FLMCR1.
4	PSU	0	R/W	Program Setup When this bit is set to 1, the flash memory changes to the program setup state. When it is cleared to 0, the program setup state is cancelled. Set this bit to 1 before setting the P bit in FLMCR1.
3	EV	0	R/W	Erase-Verify When this bit is set to 1, the flash memory changes to erase-verify mode. When it is cleared to 0, erase-verify mode is cancelled.

Bit	Bit Name	Initial Value	R/W	Description
2	PV	0	R/W	Program-Verify When this bit is set to 1, the flash memory changes to program-verify mode. When it is cleared to 0, program-verify mode is cancelled.
1	E	0	R/W	Erase When this bit is set to 1 while SWE = 1 and ESU = 1, the flash memory changes to erase mode. When it is cleared to 0, erase mode is cancelled.
0	P	0	R/W	Program When this bit is set to 1 while SWE = 1 and PSU = 1, the flash memory changes to program mode. When it is cleared to 0, program mode is cancelled.

7.2.2 Flash Memory Control Register 2 (FLMCR2)

FLMCR2 is a register that displays the state of flash memory programming/erasing. FLMCR2 is a read-only register, and should not be written to.

Bit	Bit Name	Initial Value	R/W	Description
7	FLER	0	R	Flash Memory Error Indicates that an error has occurred during an operation on flash memory (programming or erasing). When FLER is set to 1, flash memory goes to the error-protection state. See section 7.5.3, Error Protection, for details.
6 to 0	—	All 0	—	Reserved These bits are always read as 0.

7.2.3 Erase Block Register 1 (EBR1)

EBR1 specifies the flash memory erase area block. EBR1 is initialized to H'00 when the SWE bit in FLMCR1 is 0. Do not set more than one bit at a time, as this will cause all the bits in EBR1 to be automatically cleared to 0.

Bit	Bit Name	Initial Value	R/W	Description
7, 6	—	All 0	—	Reserved These bits are always read as 0.
5	EB5	0	R/W	When this bit is set to 1, 4 kbytes of H'2000 to H'2FFF will be erased.
4	EB4	0	R/W	When this bit is set to 1, 4 kbytes of H'1000 to H'1FFF will be erased.
3	EB3	0	R/W	When this bit is set to 1, 1 kbyte of H'0C00 to H'0FFF will be erased.
2	EB2	0	R/W	When this bit is set to 1, 1 kbyte of H'0800 to H'0BFF will be erased.
1	EB1	0	R/W	When this bit is set to 1, 1 kbyte of H'0400 to H'07FF will be erased.
0	EB0	0	R/W	When this bit is set to 1, 1 kbyte of H'0000 to H'03FF will be erased.

7.2.4 Flash Memory Enable Register (FENR)

Bit 7 (FLSHE) in FENR enables or disables the CPU access to the flash memory control registers, FLMCR1, FLMCR2, and EBR1.

Bit	Bit Name	Initial Value	R/W	Description
7	FLSHE	0	R/W	Flash Memory Control Register Enable Flash memory control registers can be accessed when this bit is set to 1. Flash memory control registers cannot be accessed when this bit is set to 0.
6 to 0	—	All 0	—	Reserved These bits are always read as 0.

7.3 On-Board Programming Modes

There is a mode for programming/erasing of the flash memory; boot mode, which enables on-board programming/erasing. On-board programming/erasing can also be performed in user program mode. At reset-start in reset mode, this LSI changes to a mode depending on the TEST pin settings, $\overline{\text{NMI}}$ pin settings, and input level of each port, as shown in table 7.1. The input level of each pin must be defined four states before the reset ends.

When changing to boot mode, the boot program built into this LSI is initiated. The boot program transfers the programming control program from the externally-connected host to on-chip RAM via SCI3. After erasing the entire flash memory, the programming control program is executed. This can be used for programming initial values in the on-board state or for a forcible return when programming/erasing can no longer be done in user program mode. In user program mode, individual blocks can be erased and programmed by branching to the user program/erase control program prepared by the user.

Table 7.1 Setting Programming Modes

TEST	$\overline{\text{NMI}}$	E10T_0	LSI State after Reset End
0	1	X	User mode
0	0	1	Boot mode

[Legend]

X: Don't care

7.3.1 Boot Mode

Table 7.2 shows the boot mode operations between reset end and branching to the programming control program.

1. When boot mode is used, the flash memory programming control program must be prepared in the host beforehand. Prepare a programming control program in accordance with the description in section 7.4, Flash Memory Programming/Erasing.
2. SCI3 should be set to asynchronous mode, and the transfer format as follows: 8-bit data, 1 stop bit, and no parity.

3. When the boot program is initiated, the chip measures the low-level period of asynchronous SCI communication data (H'00) transmitted continuously from the host. The chip then calculates the bit rate of transmission from the host, and adjusts the SCI3 bit rate to match that of the host. The reset should end with the RxD pin high. The RxD and TxD pins should be pulled up on the board if necessary. After the reset is complete, it takes approximately 100 states before the chip is ready to measure the low-level period.
4. After matching the bit rates, the chip transmits one H'00 byte to the host to indicate the completion of bit rate adjustment. The host should confirm that this adjustment end indication (H'00) has been received normally, and transmit one H'55 byte to the chip. If reception could not be performed normally, initiate boot mode again by a reset. Depending on the host's transfer bit rate and system clock frequency of this LSI, there will be a discrepancy between the bit rates of the host and the chip. To operate the SCI properly, set the host's transfer bit rate and system clock frequency of this LSI within the ranges listed in table 7.3.
5. In boot mode, a part of the on-chip RAM area is used by the boot program. The area H'F980 to H'FEFF is the area to which the programming control program is transferred from the host. The boot program area cannot be used until the execution state in boot mode switches to the programming control program.
6. Before branching to the programming control program, the chip terminates transfer operations by SCI3 (by clearing the RE and TE bits in SCR3 to 0), however the adjusted bit rate value remains set in BRR. Therefore, the programming control program can still use it for transfer of write data or verify data with the host. The TxD pin is high (PCR22 = 1, P22 = 1). The contents of the CPU general registers are undefined immediately after branching to the programming control program. These registers must be initialized at the beginning of the programming control program, as the stack pointer (SP), in particular, is used implicitly in subroutine calls, etc.
7. Boot mode can be cleared by a reset. End the reset after driving the reset pin low, waiting at least 20 states, and then setting the TEST pin and $\overline{\text{NMI}}$ pin. Boot mode is also cleared when a WDT overflow occurs.
8. Do not change the TEST pin and $\overline{\text{NMI}}$ pin input levels in boot mode.

Table 7.2 Boot Mode Operation

Item	Host Operation	Communication Contents	LSI Operation
	Processing Contents		Processing Contents
Boot mode initiation			Branches to boot program at reset-start. 
Bit rate adjustment	Continuously transmits data H'00 at specified bit rate. ↓ Transmits data H'55 when data H'00 is received error-free.	H'00, H'00 ··· H'00 ← H'00 → H'55	<ul style="list-style-type: none"> Measures low-level period of receive data H'00. Calculates bit rate and sets BRR in SCI3. Transmits data H'00 to host as adjustment end indication. H'55 reception.
Flash memory erase	↓ H'AA reception ←	← H'FF ← H'AA	Checks flash memory data, erases all flash memory blocks in case of written data existing, and transmits data H'AA to host. (If erase could not be done, transmits data H'FF to host and aborts operation.)
Transfer of number of bytes of programming control program	Transmits number of bytes (N) of programming control program to be transferred as 2-byte data (low-order byte following high-order byte) ↓ Transmits 1-byte of programming control program (repeated for N times) ↓ H'AA reception ←	→ Upper bytes, lower bytes ← Echoback → H'XX ← Echoback ← H'AA	Echobacks the 2-byte data received to host. ↓ Echobacks received data to host and also transfers it to RAM. (repeated for N times) ↓ Transmits data H'AA to host.
			Branches to programming control program transferred to on-chip RAM and starts execution.

Table 7.3 System Clock Frequencies for which Automatic Adjustment of LSI Bit Rate is Possible

Host Bit Rate	System Clock Frequency Range of LSI
9,600 bps	8 MHz (on-chip oscillator clock)
4,800 bps	8 MHz (on-chip oscillator clock)
2,400 bps	8 MHz (on-chip oscillator clock)

7.3.2 Programming/Erasing in User Program Mode

On-board programming/erasing of an individual flash memory block can also be performed in user program mode by branching to a user program/erase control program. The user must set branching conditions and provide on-board means of supplying programming data. The flash memory must contain the user program/erase control program or a program that provides the user program/erase control program from external memory. As the flash memory itself cannot be read during programming/erasing, transfer the user program/erase control program to on-chip RAM, as in boot mode. Figure 7.2 shows a sample procedure for programming/erasing in user program mode.

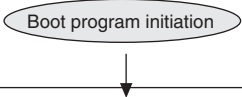
Prepare a user program/erase control program in accordance with the description in section 7.4, Flash Memory Programming/Erasing.

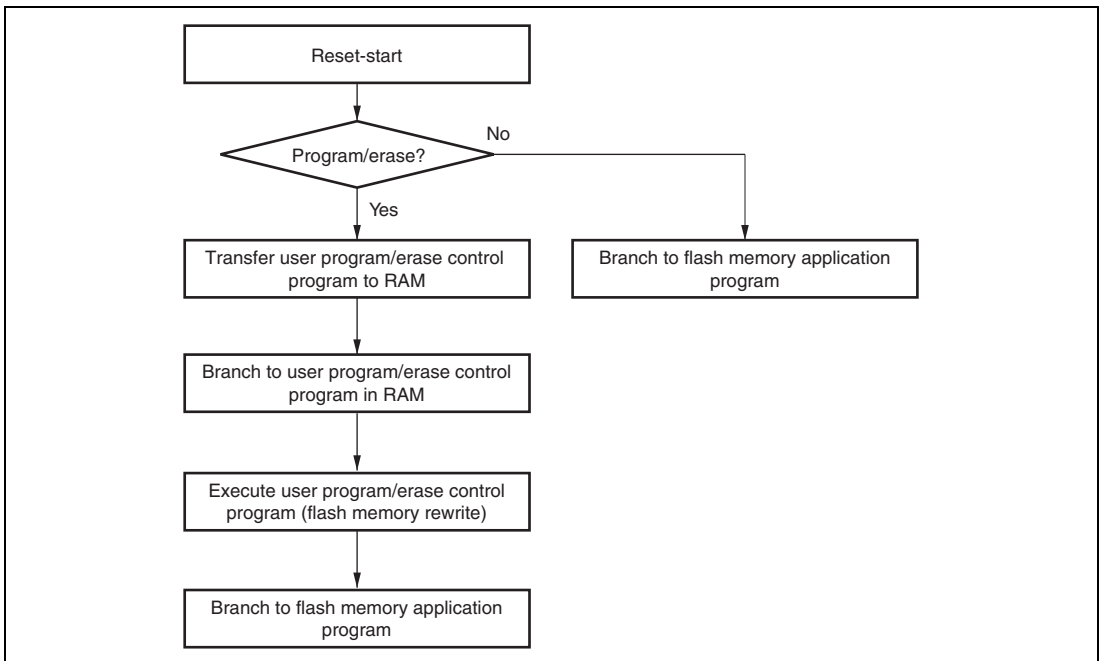

Figure 7.2 Programming/Erasing Flowchart Example in User Program Mode

7.4 Flash Memory Programming/Erasing

A software method using the CPU is employed to program and erase flash memory in the on-board programming modes. Depending on the FLMCR1 setting, the flash memory operates in one of the following four modes: Program mode, program-verify mode, erase mode, and erase-verify mode. The programming control program in boot mode and the user program/erase control program in user program mode use these operating modes in combination to perform programming/erasing. Flash memory programming and erasing should be performed in accordance with the descriptions in section 7.4.1, Program/Program-Verify and section 7.4.2, Erase/Erase-Verify, respectively.

7.4.1 Program/Program-Verify

When writing data or programs to the flash memory, the program/program-verify flowchart shown in figure 7.3 should be followed. Performing programming operations according to this flowchart will enable data or programs to be written to the flash memory without subjecting the chip to voltage stress or sacrificing program data reliability.

1. Programming must be done to an empty address. Do not reprogram an address to which programming has already been performed.
2. Programming should be carried out 64 bytes at a time. A 64-byte data transfer must be performed even if writing fewer than 64 bytes. In this case, H'FF data must be written to the extra addresses.
3. Prepare the following data storage areas in RAM: A 64-byte programming data area, a 64-byte reprogramming data area, and a 64-byte additional-programming data area. Perform reprogramming data computation according to table 7.4, and additional programming data computation according to table 7.5.
4. Consecutively transfer 64 bytes of data in byte units from the reprogramming data area or additional-programming data area to the flash memory. The program address and 64-byte data are latched in the flash memory. The lower 8 bits of the start address in the flash memory destination area must be H'00, H'40, H'80, or H'C0.
5. The time during which the P bit is set to 1 is the programming time. Table 7.6 shows the allowable programming times.
6. The watchdog timer (WDT) is set to prevent overprogramming due to program runaway, etc. An overflow cycle of approximately 6.6 ms is allowed.
7. For a dummy write to a verify address, write 1-byte data H'FF to an even address. Verify data can be read in words from the address to which a dummy write was performed.
8. The maximum number of repetitions of the program/program-verify sequence of the same bit is 1,000.

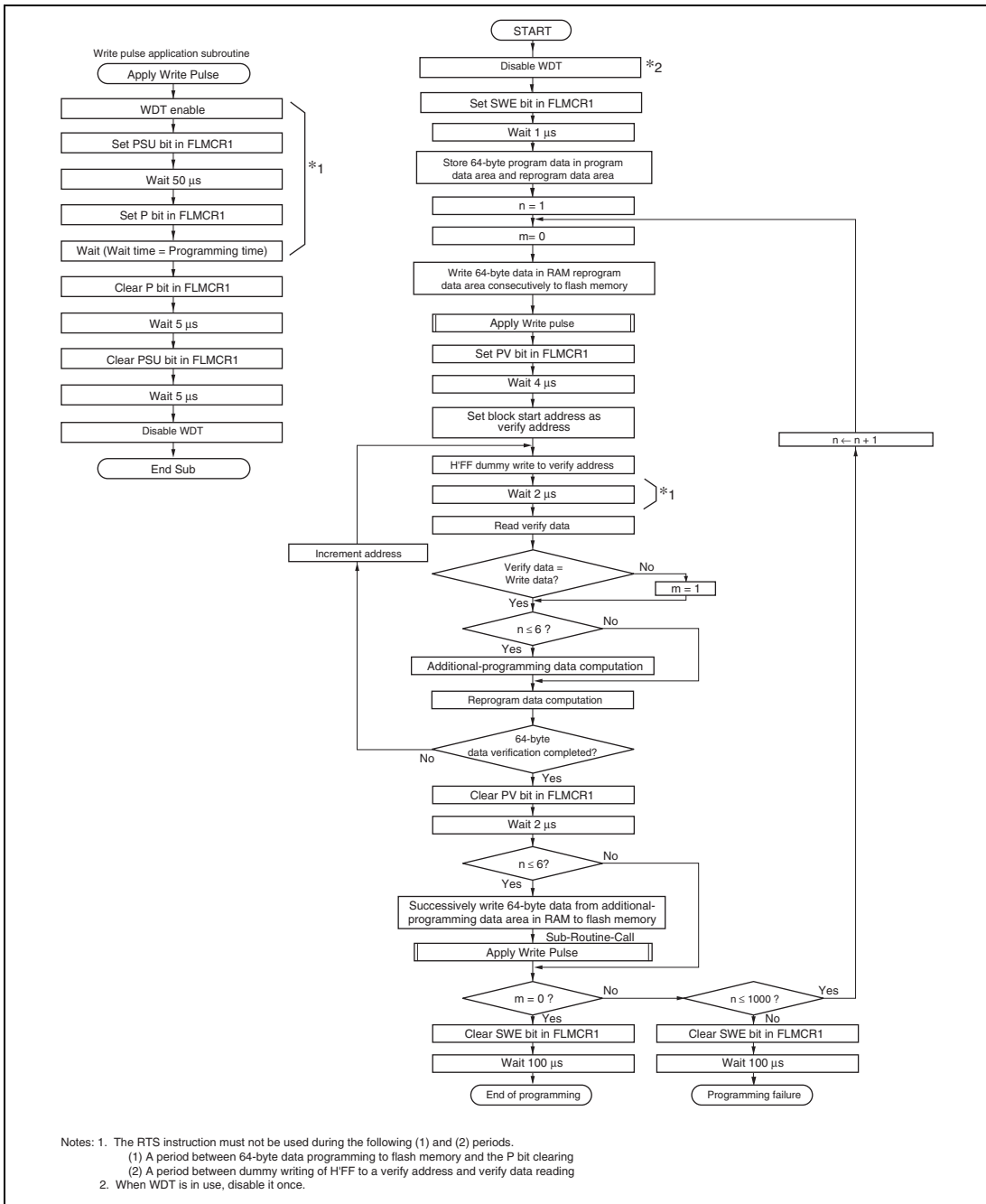

Figure 7.3 Program/Program-Verify Flowchart

Table 7.4 Reprogram Data Computation Table

Program Data	Verify Data	Reprogram Data	Comments
0	0	1	Programming completed
0	1	0	Reprogram bit
1	0	1	—
1	1	1	Remains in erased state

Table 7.5 Additional-Program Data Computation Table

Reprogram Data	Verify Data	Additional-Program Data	Comments
0	0	0	Additional-program bit
0	1	1	No additional programming
1	0	1	No additional programming
1	1	1	No additional programming

Table 7.6 Programming Time

n (Number of Writes)	Programming Time	In Additional Programming	Comments
1 to 6	30	10	
7 to 1,000	200	—	

Note: Time shown in μ s.

7.4.2 Erase/Erase-Verify

When erasing flash memory, the erase/erase-verify flowchart shown in figure 7.4 should be followed.

1. Prewriting (setting erase block data to all 0s) is not necessary.
2. Erasing is performed in block units. Make only a single-bit specification in the erase block register (EBR1). To erase multiple blocks, each block must be erased in turn.
3. The time during which the E bit is set to 1 is the flash memory erase time.
4. The watchdog timer (WDT) is set to prevent overerasing due to program runaway, etc. An overflow cycle of approximately 19.8 ms is allowed.
5. For a dummy write to a verify address, write 1-byte data H'FF to an even address. Verify data can be read in words from the address to which a dummy write was performed.

6. If the read data is not erased successfully, set erase mode again, and repeat the erase/erase-verify sequence as before. The maximum number of repetitions of the erase/erase-verify sequence is 100.

7.4.3 Interrupt Handling when Programming/Erasing Flash Memory

All interrupts, including the $\overline{\text{NMI}}$ interrupt, are disabled while flash memory is being programmed or erased, or while the boot program is executing, for the following three reasons:

1. Interrupt during programming/erasing may cause a violation of the programming or erasing algorithm, with the result that normal operation cannot be assured.
2. If interrupt exception handling starts before the vector address is written or during programming/erasing, a correct vector cannot be fetched and the CPU malfunctions.
3. If an interrupt occurs during boot program execution, normal boot mode sequence cannot be carried out.

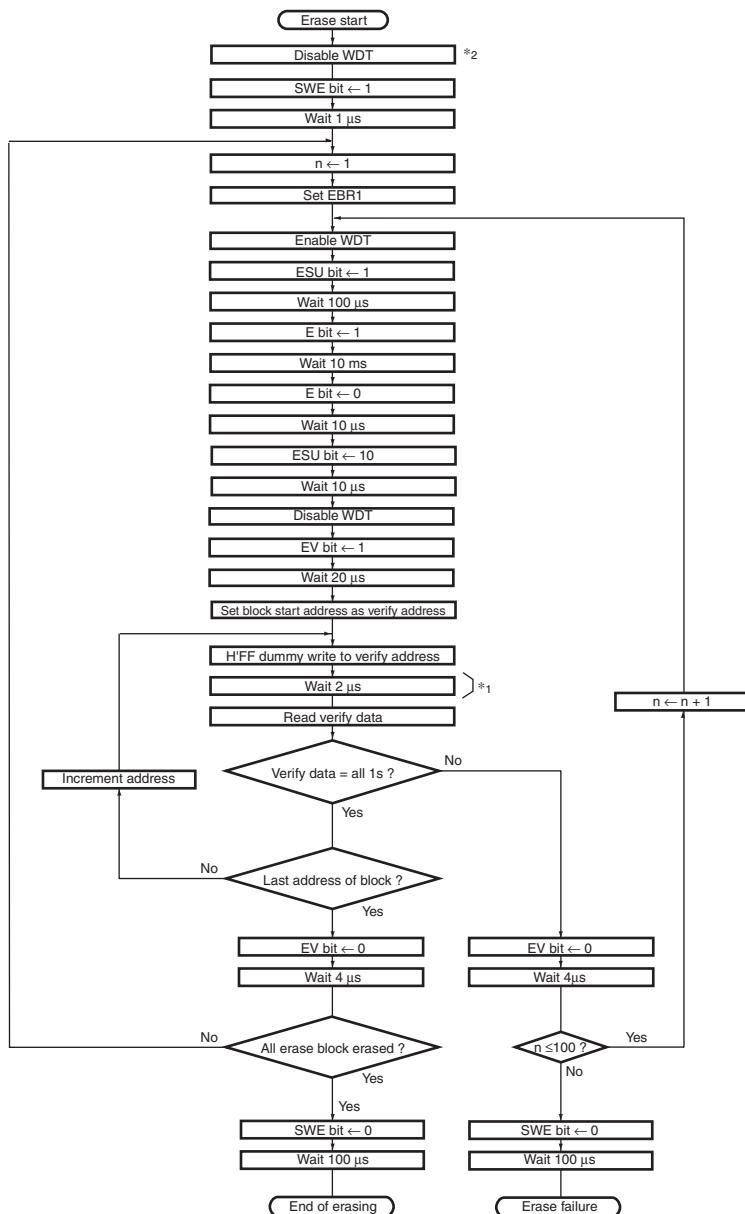

Notes: 1. The RTS instruction must not be used during a period between dummy writing of H'FF to a verify address and verify data reading.
 2. When WDT is in use, disable it once.

Figure 7.4 Erase/Erase-Verify Flowchart

7.5 Program/Erase Protection

There are three kinds of flash memory program/erase protection; hardware protection, software protection, and error protection.

7.5.1 Hardware Protection

Hardware protection refers to a state in which programming/erasing of flash memory is forcibly disabled or aborted because of a transition to reset, subsleep mode or standby mode. Flash memory control register 1 (FLMCR1), flash memory control register 2 (FLMCR2), and erase block register 1 (EBR1) are initialized. In a reset via the $\overline{\text{RES}}$ pin, the reset state is not entered unless the $\overline{\text{RES}}$ pin is held low until oscillation stabilizes after powering on. In the case of a reset during operation, hold the $\overline{\text{RES}}$ pin low for the $\overline{\text{RES}}$ pulse width specified in the AC Characteristics section.

7.5.2 Software Protection

Software protection can be implemented against programming/erasing of all flash memory blocks by clearing the SWE bit in FLMCR1. When software protection is in effect, setting the P or E bit in FLMCR1 does not cause a transition to program mode or erase mode. By setting the erase block register 1 (EBR1), erase protection can be set for individual blocks. When EBR1 is set to H'00, erase protection is set for all blocks.

7.5.3 Error Protection

In error protection, an error is detected when CPU runaway occurs during flash memory programming/erasing, or operation is not performed in accordance with the program/erase algorithm, and the program/erase operation is aborted. Aborting the program/erase operation prevents damage to the flash memory due to overprogramming or overerasing.

When the following errors are detected during programming/erasing of flash memory, the FLER bit in FLMCR2 is set to 1, and the error protection state is entered.

- When the flash memory of the relevant address area is read during programming/erasing (including vector read and instruction fetch)
- Immediately after exception handling excluding a reset during programming/erasing
- When a SLEEP instruction is executed during programming/erasing

The FLMCR1, FLMCR2, and EBR1 settings are retained, however program mode or erase mode is aborted at the point at which the error occurred. Program mode or erase mode cannot be re-entered by re-setting the P or E bit. However, PV and EV bit setting is enabled, and a transition can be made to verify mode. Error protection can be cleared only by a reset.

Section 8 RAM

The H8/36912F and H8/36902F have 1536 bytes, the H8/36912 and H8/36902 have 512 bytes, and the H8/36911, H8/36901, and H8/36900 have 256 bytes of on-chip high-speed static RAM, respectively. The RAM is connected to the CPU by a 16-bit data bus, enabling two-state access by the CPU to both byte data and word data.

Product Classification		RAM Size	RAM Address
Flash memory version	H8/36912F	1536 bytes	H'F980 to H'FF7F*
	H8/36902F	1536 bytes	H'F980 to H'FF7F*
Masked ROM version	H8/36912, H8/36902	512 bytes	H'FD80 to H'FF7F
	H8/36911, H8/36901	256 bytes	H'FE80 to H'FF7F
	H8/36900	256 bytes	H'FE80 to H'FF7F

Note: * When the E7 or E8 is used, area H'F980 to H'FD7F must not be accessed.

Section 9 I/O Ports

The LSI of the H8/36912 Group and H8/36902 Group has 18 general I/O ports. Port 8 (P84 to P80) is a large current port, which can drive 20 mA ($@V_{OL} = 1.5\text{ V}$) when a low level signal is output. Any of these ports can become an input port immediately after a reset. They can also be used as I/O pins of the on-chip peripheral modules or external interrupt input pins, and these functions can be switched depending on the register settings. The registers for selecting these functions can be divided into two types: those included in I/O ports and those included in each on-chip peripheral module. General I/O ports are comprised of the port control register for controlling inputs/outputs and the port data register for storing output data and can select inputs/outputs in bit units. For functions in each port, see appendix B.1, I/O Port Block Diagrams. For the execution of bit manipulation instructions to the port control register and port data register, see section 2.8.3, Bit Manipulation Instruction.

9.1 Port 1

Port 1 is a general I/O port also functioning as an IRQ interrupt input pin and timer V input pin. Figure 9.1 shows its pin configuration.

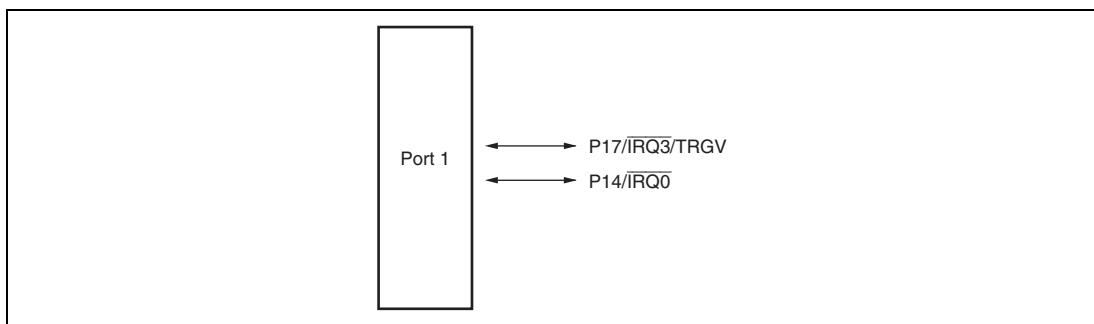

Figure 9.1 Port 1 Pin Configuration

Port 1 has the following registers.

- Port mode register 1 (PMR1)
- Port control register 1 (PCR1)
- Port data register 1 (PDR1)
- Port pull-up control register 1 (PUCR1)

9.1.1 Port Mode Register 1 (PMR1)

PMR1 switches the functions of pins in port 1 and port 2.

Bit	Bit Name	Initial Value	R/W	Description
7	IRQ3	0	R/W	P17/ $\overline{\text{IRQ3}}$ /TRGV Pin Function Switch Selects whether pin P17/ $\overline{\text{IRQ3}}$ /TRGV is used as P17 or as IRQ3/TRGV. 0: General I/O port 1: $\overline{\text{IRQ3}}$ /TRGV input pin
6, 5	—	All 0	—	Reserved These bits are always read as 0.
4	IRQ0	0	R/W	P14/ $\overline{\text{IRQ0}}$ Pin Function Switch Selects whether pin P14/ $\overline{\text{IRQ0}}$ is used as P14 or as IRQ0. 0: General I/O port 1: $\overline{\text{IRQ0}}$ input pin
3, 2	—	All 0	—	Reserved These bits are always read as 0.
1	TXD	0	R/W	P22/TXD Pin Function Switch Selects whether pin P22/TXD is used as P22 or as TXD. 0: General I/O port 1: TXD output pin
0	—	0	—	Reserved This bit is always read as 0.

9.1.2 Port Control Register 1 (PCR1)

PCR1 selects inputs/outputs in bit units for pins to be used as general I/O ports of port 1.

Bit	Bit Name	Initial Value	R/W	Description
7	PCR17	0	W	When the corresponding pin is designated in PMR1 as a general I/O pin, setting a PCR1 bit to 1 makes the corresponding pin an output port, while clearing the bit to 0 makes the pin an input port.
6	—	—	—	
5	—	—	—	Bits 6, 5, and 3 to 0 are reserved.
4	PCR14	0	W	
3	—	—	—	
2	—	—	—	
1	—	—	—	
0	—	—	—	

9.1.3 Port Data Register 1 (PDR1)

PDR1 is a general I/O port data register of port 1.

Bit	Bit Name	Initial Value	R/W	Description
7	P17	0	R/W	These bits store output data for port 1 pins.
6	—	1	—	If PDR1 is read while PCR1 bits are set to 1, the value stored in PDR1 are read. If PDR1 is read while PCR1 bits are cleared to 0, the pin states are read regardless of the value stored in PDR1.
5	—	1	—	
4	P14	0	R/W	Bits 6, 5, and 3 to 0 are reserved. These bits are always read as 1.
3	—	1	—	
2	—	1	—	
1	—	1	—	
0	—	1	—	

9.1.4 Port Pull-Up Control Register 1 (PUCR1)

PUCR1 controls the pull-up MOS in bit units of the pins set as the input ports.

Bit	Bit Name	Initial Value	R/W	Description
7	PUCR17	0	R/W	Only bits for which PCR1 is cleared are valid.
6	—	1	—	The pull-up MOS of the P17 and P14 pins enter the on-state when these bits are set to 1, while they enter the off-state when these bits are cleared to 0.
5	—	1	—	
4	PUCR14	0	R/W	Bits 6, 5, and 3 to 0 are reserved. These bits are always read as 1.
3	—	1	—	
2	—	1	—	
1	—	1	—	
0	—	1	—	

9.1.5 Pin Functions

The correspondence between the register specification and the port functions is shown below.

- P17/IRQ3/TRGV pin

Register	PMR1	PCR1	
Bit Name	IRQ3	PCR17	Pin Function
Setting value 0		0	P17 input pin
		1	P17 output pin
	1	X	$\overline{\text{IRQ3}}$ input/TRGV input pin

[Legend]

X: Don't care

- P14/ $\overline{\text{IRQ0}}$ pin

Register	PMR1	PCR1	
Bit Name	IRQ0	PCR14	Pin Function
Setting value 0		0	P14 input pin
		1	P14 output pin
	1	X	$\overline{\text{IRQ0}}$ input pin

[Legend]

X: Don't care

9.2 Port 2

Port 2 is a general I/O port also functioning as a SCI3 I/O pin. Each pin of the port 2 is shown in figure 9.2. The register settings of PMR1 and SCI3 have priority for functions of the pins for both uses.

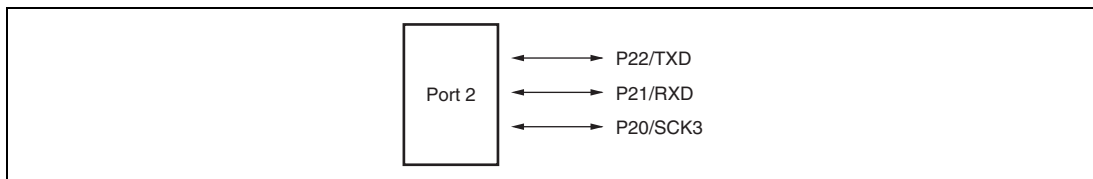

Figure 9.2 Port 2 Pin Configuration

Port 2 has the following registers.

- Port control register 2 (PCR2)
- Port data register 2 (PDR2)

9.2.1 Port Control Register 2 (PCR2)

PCR2 selects inputs/outputs in bit units for pins to be used as general I/O ports of port 2.

Bit	Bit Name	Initial Value	R/W	Description
7 to 3	—	—	—	Reserved
2	PCR22	0	W	When each of the port 2 pins, P22 to P20, functions as an general I/O port, setting a PCR2 bit to 1 makes the corresponding pin an output port, while clearing the bit to 0 makes the pin an input port.
1	PCR21	0	W	
0	PCR20	0	W	

9.2.2 Port Data Register 2 (PDR2)

PDR2 is a general I/O port data register of port 2.

Bit	Bit Name	Initial Value	R/W	Description
7 to 3	—	All 1	—	Reserved These bits are always read as 1.
2	P22	0	R/W	These bits store output data for port 2 pins.
1	P21	0	R/W	If PDR2 is read while PCR2 bits are set to 1, the value stored in PDR2 is read. If PDR2 is read while PCR2 bits are cleared to 0, the pin states are read regardless of the value stored in PDR2.
0	P20	0	R/W	

9.2.3 Pin Functions

The correspondence between the register specification and the port functions is shown below.

- P22/TXD pin

Register	PMR1	PCR2	
Bit Name	TXD	PCR22	Pin Function
Setting value	0	0	P22 input pin
		1	P22 output pin
	1	X	TXD output pin

[Legend]

X: Don't care

- P21/RXD pin

Register	SCR3	PCR2	
Bit Name	RE	PCR21	Pin Function
Setting value	0	0	P21 input pin
		1	P21 output pin
	1	X	RXD input pin

[Legend]

X: Don't care

- P20/SCK3 pin

Register	SCR3		SMR	PCR2	
Bit Name	CKE1	CKE0	COM	PCR20	Pin Function
Setting value	0	0	0	0	P20 input pin
				1	P20 output pin
	0	0	1	X	SCK3 output pin
	0	1	X	X	SCK3 output pin
	1	X	X	X	SCK3 input pin

[Legend]

X: Don't care

9.3 Port 5

Port 5 is a general I/O port also functioning as an I²C bus interface I/O pin*, A/D trigger input pin, and wakeup interrupt input pin. Each pin of the port 5 is shown in figure 9.3. The register setting of the I²C bus interface has priority for functions of the P57/SCL and P56/SDA pins.

Note: * Supported only by the H8/36912 Group.

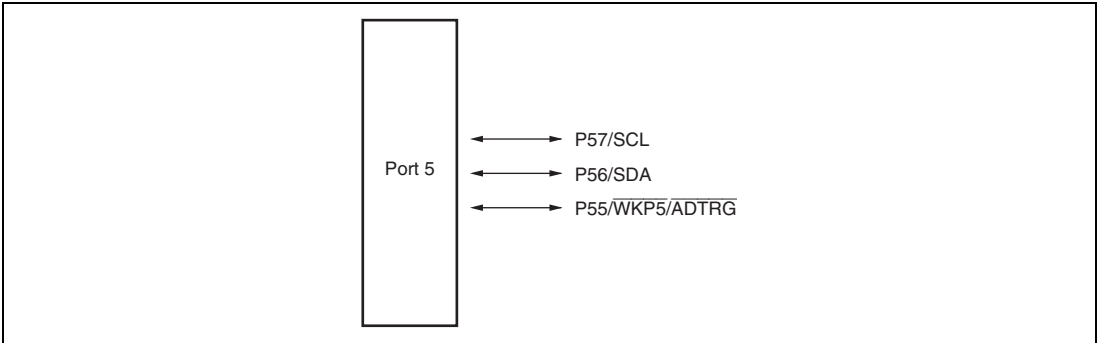

Figure 9.3 Port 5 Pin Configuration

Port 5 has the following registers.

- Port mode register 5 (PMR5)
- Port control register 5 (PCR5)
- Port data register 5 (PDR5)
- Port pull-up control register 5 (PUCR5)

9.3.1 Port Mode Register 5 (PMR5)

PMR5 switches the functions of pins in port 5.

Bit	Bit Name	Initial Value	R/W	Description
7, 6	—	All 0	—	Reserved These bits are always read as 0.
5	WKP5	0	R/W	P55/ $\overline{\text{WKP5}}$ / $\overline{\text{ADTRG}}$ Pin Function Switch Selects whether pin P55/ $\overline{\text{WKP5}}$ / $\overline{\text{ADTRG}}$ is used as P55 or as $\overline{\text{WKP5}}$ / $\overline{\text{ADTRG}}$. 0: General I/O port 1: $\overline{\text{WKP5}}$ / $\overline{\text{ADTRG}}$ input pin
4 to 0	—	All 0	—	Reserved These bits are always read as 0.

9.3.2 Port Control Register 5 (PCR5)

PCR5 selects inputs/outputs in bit units for pins to be used as general I/O ports of port 5.

Bit	Bit Name	Initial Value	R/W	Description
7	PCR57	0	W	When each of the port 5 pins, P57 to P55, functions as an general I/O port, setting a PCR5 bit to 1 makes the corresponding pin an output port, while clearing the bit to 0 makes the pin an input port.
6	PCR56	0	W	
5	PCR55	0	W	
4 to 0	—	—	—	Reserved

9.3.3 Port Data Register 5 (PDR5)

PDR5 is a general I/O port data register of port 5.

Bit	Bit Name	Initial Value	R/W	Description
7	P57	0	R/W	These bits store output data for port 5 pins.
6	P56	0	R/W	If PDR5 is read while PCR5 bits are set to 1, the value stored in PDR5 are read. If PDR5 is read while PCR5 bits are cleared to 0, the pin states are read regardless of the value stored in PDR5.
5	P55	0	R/W	
4 to 0	—	All 1	—	Reserved These bits are always read as 1.

9.3.4 Port Pull-Up Control Register 5 (PUCR5)

PUCR5 controls the pull-up MOS in bit units of the pins set as the input ports.

Bit	Bit Name	Initial Value	R/W	Description
7, 6	—	All 0	—	Reserved These bits are always read as 0.
5	PUCR55	0	R/W	Only bits for which PCR5 is cleared are valid. The pull-up MOS of the corresponding pins enter the on-state when this bit is set to 1, while they enter the off-state when this bit is cleared to 0.
4 to 0	—	All 0	—	Reserved These bits are always read as 0.

9.3.5 Pin Functions

The correspondence between the register specification and the port functions is shown below.

- P57/SCL pin

Register	ICCR	PCR5	
Bit Name	ICE	PCR57	Pin Function
Setting value	0	0	P57 input pin
		1	P57 output pin
	1	X	SCL I/O pin*

[Legend]

X: Don't care

Note: As the SCL output form is NMOS open-drain, direct bus drive is enabled.

* Supported only by the H8/36912 Group.

- P56/SDA pin

Register	ICCR	PCR5	
Bit Name	ICE	PCR56	Pin Function
Setting value	0	0	P56 input pin
		1	P56 output pin
	1	X	SDA I/O pin*

[Legend]

X: Don't care

Note: As the SDA output form is NMOS open-drain, direct bus drive is enabled.

* Supported only by the H8/36912 Group.

- P55/ $\overline{\text{WKP5}}$ / $\overline{\text{ADTRG}}$ pin

Register	PMR5	PCR5	
Bit Name	WKP5	PCR55	Pin Function
Setting value	0	0	P55 input pin
		1	P55 output pin
	1	X	$\overline{\text{WKP5/ADTRG}}$ input pin

[Legend]

X: Don't care

9.4 Port 7

Port 7 is a general I/O port also functioning as a timer V I/O pin. Each pin of the port 7 is shown in figure 9.4. The register setting of TCSR_V in timer V has priority for functions of the P76/TMOV pin. The pins, P75/TMCIV and P74/TMRIV, are also functioning as timer V input ports that are connected to the timer V regardless of the register setting of port 7.

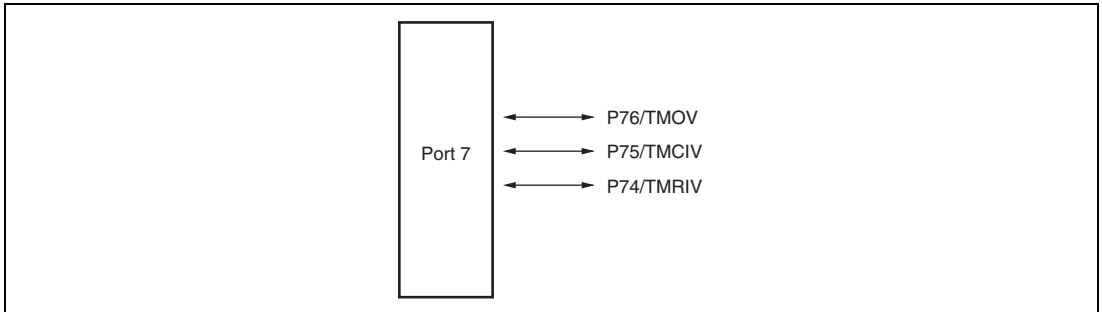

Figure 9.4 Port 7 Pin Configuration

Port 7 has the following registers.

- Port control register 7 (PCR7)
- Port data register 7 (PDR7)

9.4.1 Port Control Register 7 (PCR7)

PCR7 selects inputs/outputs in bit units for pins to be used as general I/O ports of port 7.

Bit	Bit Name	Initial Value	R/W	Description
7	—	—	—	Reserved
6	PCR76	0	W	Setting a PCR7 bit to 1 makes the corresponding pin an output port, while clearing the bit to 0 makes the pin an input port. Note that the TCSR _V setting of the timer V has priority for deciding input/output direction of the P76/TMOV pin.
5	PCR75	0	W	
4	PCR74	0	W	
3 to 0	—	—	—	Reserved

9.4.2 Port Data Register 7 (PDR7)

PDR7 is a general I/O port data register of port 7.

Bit	Bit Name	Initial Value	R/W	Description
7	—	1	—	Reserved This bit is always read as 1.
6	P76	0	R/W	These bits store output data for port 7 pins.
5	P75	0	R/W	If PDR7 is read while PCR7 bits are set to 1, the value stored in PDR7 is read. If PDR7 is read while PCR7 bits are cleared to 0, the pin states are read regardless of the value stored in PDR7.
4	P74	0	R/W	
3 to 0	—	All 1	—	Reserved These bits are always read as 1.

9.4.3 Pin Functions

The correspondence between the register specification and the port functions is shown below.

- P76/TMOV pin

Register	TCSR.V	PCR7	
Bit Name	OS3 to OS0	PCR76	Pin Function
Setting value	0000	0	P76 input pin
		1	P76 output pin
	Other than the above values	X	TMOV output pin

[Legend]

X: Don't care

- P75/TMCIV pin

Register	PCR7	
Bit Name	PCR75	Pin Function
Setting value	0	P75 input/TMCIV input pin
	1	P75 output/TMCIV input pin

- P74/TMRIV pin

Register	PCR7	
Bit Name	PCR74	Pin Function
Setting value	0	P74 input/TMRIV input pin
	1	P74 output/TMRIV input pin

9.5 Port 8

Port 8 is a general I/O port also functioning as a timer W I/O pin. Each pin of the port 8 is shown in figure 9.5. The register setting of the timer W has priority for functions of the P84/FTIOD, P83/FTIOC, P82/FTIOB, and P81/FTIOA pins. The P80/FTCI pin also functions as a timer W input port that is connected to the timer W regardless of the register setting of port 8.

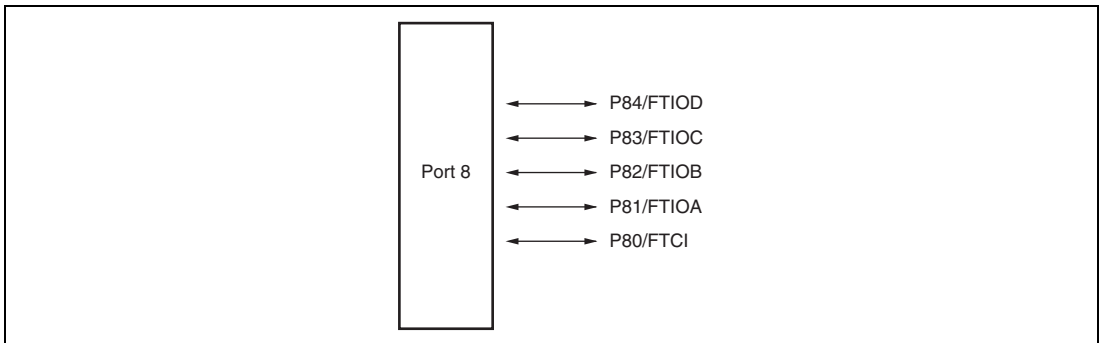

Figure 9.5 Port 8 Pin Configuration

Port 8 has the following registers.

- Port control register 8 (PCR8)
- Port data register 8 (PDR8)

9.5.1 Port Control Register 8 (PCR8)

PCR8 selects inputs/outputs in bit units for pins to be used as general I/O ports of port 8.

Bit	Bit Name	Initial Value	R/W	Description
7 to 5	—	—	—	Reserved
4	PCR84	0	W	When each of the port 8 pins, P84 to P80, functions as an general I/O port, setting a PCR8 bit to 1 makes the corresponding pin an output port, while clearing the bit to 0 makes the pin an input port.
3	PCR83	0	W	
2	PCR82	0	W	
1	PCR81	0	W	
0	PCR80	0	W	

9.5.2 Port Data Register 8 (PDR8)

PDR8 is a general I/O port data register of port 8.

Bit	Bit Name	Initial Value	R/W	Description
7 to 5	—	All 0	—	Reserved
4	P84	0	R/W	These bits store output data for port 8 pins.
3	P83	0	R/W	If PDR8 is read while PCR8 bits are set to 1, the value stored in PDR8 is read. If PDR8 is read while PCR8 bits are cleared to 0, the pin states are read regardless of the value stored in PDR8.
2	P82	0	R/W	
1	P81	0	R/W	
0	P80	0	R/W	

9.5.3 Pin Functions

The correspondence between the register specification and the port functions is shown below.

- P84/FTIOD pin

Register	TMRW	TIOR1			PCR8	Pin Function
Bit Name	PWMD	IOD2	IOD1	IOD0	PCR84	
Setting value	0	0	0	0	0	P84 input/FTIOD input pin
					1	P84 output/FTIOD input pin
		0	0	1	X	FTIOD output pin
		0	1	X	X	FTIOD output pin
		1	X	X	0	P84 input/FTIOD input pin
					1	P84 output/FTIOD input pin
	1	X	X	X	X	PWM output pin

[Legend]

X: Don't care

- P83/FTIOC pin

Register	TMRW	TIOR1			PCR8	Pin Function
Bit Name	PWMC	IOC2	IOC1	IOC0	PCR83	
Setting value	0	0	0	0	0	P83 input/FTIOC input pin
					1	P83 output/FTIOC input pin
		0	0	1	X	FTIOC output pin
		0	1	X	X	FTIOC output pin
		1	X	X	0	P83 input/FTIOC input pin
					1	P83 output/FTIOC input pin
	1	X	X	X	X	PWM output pin

[Legend]

X: Don't care

- P82/FTIOB pin

Register	TMRW		TIOR0		PCR8		
Bit Name	PWMB	IOB2	IOB1	IOB0	PCR82	Pin Function	
Setting value	0	0	0	0	0	P82 input/FTIOB input pin	
					1	P82 output/FTIOB input pin	
		0	0	1	X	FTIOB output pin	
		0	1	X	X	FTIOB output pin	
		1	X	X	X	0	P82 input/FTIOB input pin
						1	P82 output/FTIOB input pin
		1	X	X	X	X	PWM output pin

[Legend]

X: Don't care

- P81/FTIOA pin

Register	TIOR0			PCR8			
Bit Name	IOA2	IOA1	IOA0	PCR81	Pin Function		
Setting value	0	0	0	0	P81 input/FTIOA input pin		
				1	P81 output/FTIOA input pin		
		0	0	1	X	FTIOA output pin	
		0	1	X	X	FTIOA output pin	
		1	X	X	X	0	P81 input/FTIOA input pin
						1	P81 output/FTIOA input pin

[Legend]

X: Don't care

- P80/FTCI pin

Register	PCR8	
Bit Name	PCR80	Pin Function
Setting value	0	P80 input/FTCI input pin
	1	P80 output/FTCI input pin

9.6 Port B

Port B is an input port also functioning as an A/D converter analog input pin and LVD external comparison voltage input pin. Each pin of the port B is shown in figure 9.6.

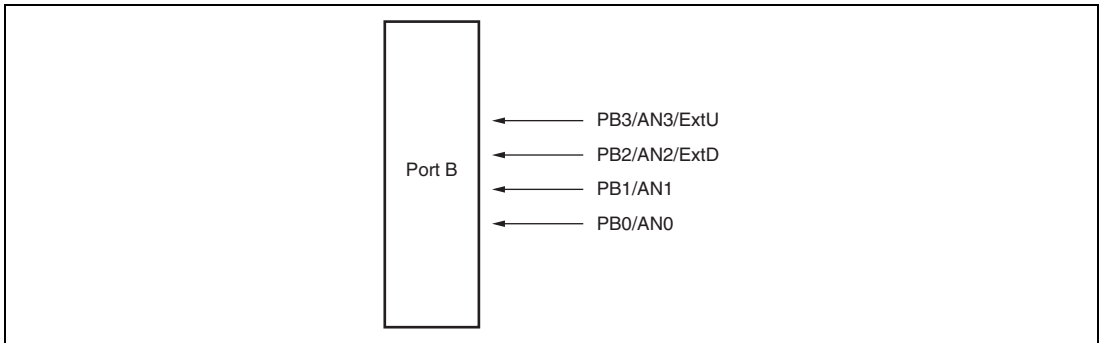

Figure 9.6 Port B Pin Configuration

Port B has the following register.

- Port data register B (PDRB)

9.6.1 Port Data Register B (PDRB)

PDRB is a general input-only port data register of port B.

Bit	Bit Name	Initial Value	R/W	Description
7 to 4	—	—	—	Reserved
3	PB3	—	R	The input value of each pin is read by reading this register.
2	PB2	—	R	
1	PB1	—	R	However, if a port B pin is designated as an analog input channel by ADCSR in A/D converter or external comparison voltage input pin by LVDCCR in low-voltage detection circuit, 0 is read.
0	PB0	—	R	

9.6.2 Pin Functions

The correspondence between the register specification and the port functions is shown below.

- PB3/AN3/ExtU pin

Register	ADCSR			LVDICR	
Bit Name	CH2	CH1	CH0	VDDII	Pin Function
Setting value	0	1	1	1	AN3 input pin
				0	AN3 input/ExtU input pin
	Other than the above values			1	PB3 input pin
				0	PB3 input/ExtU input pin

- PB2/AN2/ExtD pin

Register	ADCSR				LVDICR	
Bit Name	CH2	SCAN	CH1	CH0	VDDII	Pin Function
Setting value	0	0	1	0	1	AN2 input pin
	0	1	1	X	0	AN2 input/ExtD input pin
	Other than the above values				1	PB2 input pin
					0	PB2 input/ExtD input pin

[Legend]

X: Don't care

- PB1/AN1 pin

Register	ADCSR				
Bit Name	CH2	SCAN	CH1	CH0	Pin Function
Setting value	0	X	0	1	AN1 input pin
	0	1	1	X	
	Other than the above values				PB1 input pin

[Legend]

X: Don't care

- PB0/AN0 pin

Register	ADCSR				Pin Function
Bit Name	CH2	SCAN	CH1	CH0	
Setting	0	0	0	0	AN0 input pin
value	0	1	X	X	
	Other than the above values				PB0 input pin

[Legend]

X: Don't care

9.7 Port C

Port C is a general I/O port also functioning as an external oscillation pin and clock output pin. Each pin of the port C is shown in figure 9.7. The register setting of CKCSR has priority for functions of the pins for both uses.

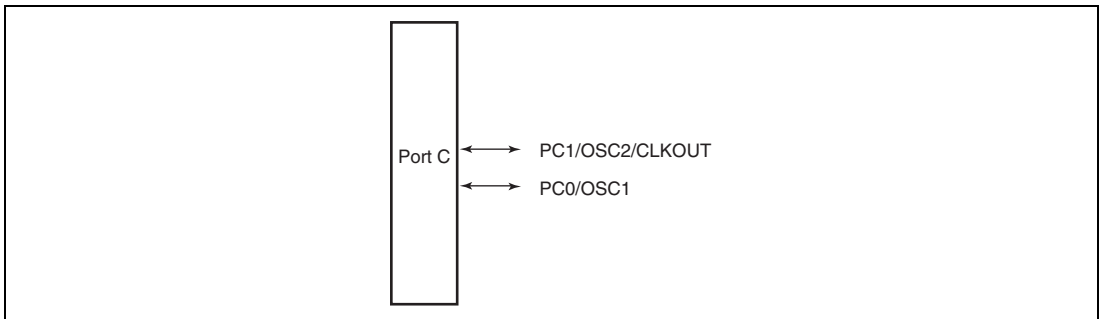

Figure 9.7 Port C Pin Configuration

Port C has the following registers.

- Port control register C (PCRC)
- Port data register C (PDRC)

9.7.1 Port Control Register C (PCRC)

PCRC selects inputs/outputs in bit units for pins to be used as general I/O ports of port C.

Bit	Bit Name	Initial Value	R/W	Description
7 to 2	—	—	—	Reserved
1	PCRC1	0	W	When each of the port C pins, PC1 and PC0, functions as an general I/O port, setting a PCRC bit to 1 makes the corresponding pin an output port, while clearing the bit to 0 makes the pin an input port.
0	PCRC0	0	W	

9.7.2 Port Data Register C (PDRC)

PDRC is a general I/O port data register of port C.

Bit	Bit Name	Initial Value	R/W	Description
7 to 2	—	—	—	Reserved
1	PC1	0	R/W	These bits store output data for port C pins. If PDRC is read while PCRC bits are set to 1, the value stored in PDRC is read. If PDRC is read while PCRC bits are cleared to 0, the pin states are read regardless of the value stored in PDRC.
0	PC0	0	R/W	

9.7.3 Pin Functions

The correspondence between the register specification and the port functions is shown below.

- PC1/OSC2/CLKOUT pin

Register	CKCSR		PCRC	
Bit Name	PMRC1	PMRC0	PCRC1	Pin Function
Setting value 0	0	X	0	PC1 input pin
			1	PC1 output pin
1	1	0	X	CLKOUT output pin
		1	X	OSC2 oscillation pin

[Legend]

X: Don't care

- PC0/OSC1 pin

Register	CKCSR	PCRC	
Bit Name	PMRC0	PCRC0	Pin Function
Setting value 0	0	0	PC0 input pin
		1	PC0 output pin
1	1	X	OSC1 oscillation pin

[Legend]

X: Don't care

Section 10 Timer B1

Timer B1 is an 8-bit timer that increments each time a clock pulse is input. This timer has two operating modes, interval and auto reload. Figure 10.1 shows a block diagram of timer B1.

10.1 Features

- Selection of seven internal clock sources ($\phi/8192$, $\phi/2048$, $\phi/512$, $\phi/256$, $\phi/64$, $\phi/16$, and $\phi/4$)
- An interrupt is generated when the counter overflows.

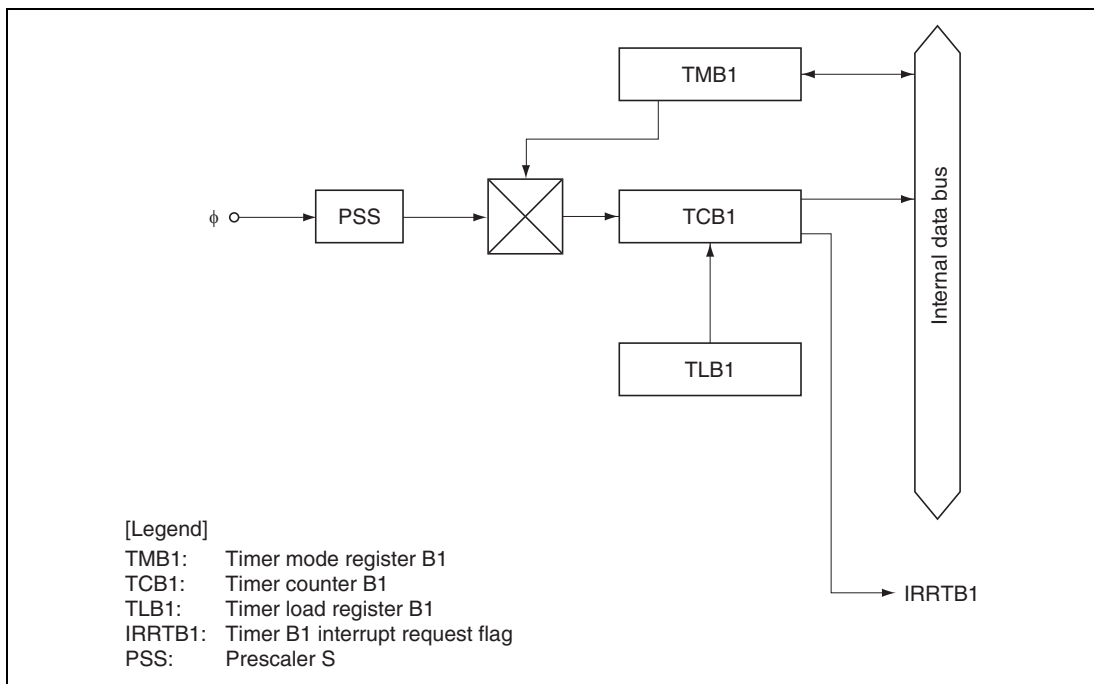

Figure 10.1 Block Diagram of Timer B1

10.2 Register Descriptions

The timer B1 has the following registers.

- Timer mode register B1 (TMB1)
- Timer counter B1 (TCB1)
- Timer load register B1 (TLB1)

10.2.1 Timer Mode Register B1 (TMB1)

TMB1 selects the auto-reload function and input clock.

Bit	Bit Name	Initial Value	R/W	Description
7	TMB17	0	R/W	Auto-Reload Function Select 0: Interval timer function selected 1: Auto-reload function selected
6	—	1	R/W	Reserved Although this bit is readable/writable, it should not be set to 0.
5 to 3	—	All 1	—	Reserved These bits are always read as 1.
2	TMB12	0	R/W	Clock Select
1	TMB11	0	R/W	000: Internal clock: $\phi/8192$
0	TMB10	0	R/W	001: Internal clock: $\phi/2048$ 010: Internal clock: $\phi/512$ 011: Internal clock: $\phi/256$ 100: Internal clock: $\phi/64$ 101: Internal clock: $\phi/16$ 110: Internal clock: $\phi/4$ 111: Reserved (setting prohibited)

10.2.2 Timer Counter B1 (TCB1)

TCB1 is an 8-bit read-only up-counter, which is incremented by internal clock input. The clock source for input to this counter is selected by bits TMB12 to TMB10 in TMB1. TCB1 values can be read by the CPU at any time. When TCB1 overflows from H'FF to H'00 or to the value set in TLB1, the IRRTB1 flag in IRR2 is set to 1. TCB1 is allocated to the same address as TLB1.

10.2.3 Timer Load Register B1 (TLB1)

TLB1 is an 8-bit write-only register for setting the reload value of TCB1. When a reload value is set in TLB1, the same value is loaded into TCB1 as well, and TCB1 starts counting up from that value. When TCB1 overflows during operation in auto-reload mode, the TLB1 value is loaded into TCB1. Accordingly, overflow periods can be set within the range of 1 to 256 input clocks. TLB1 is allocated to the same address as TCB1.

10.3 Operation

10.3.1 Interval Timer Operation

When bit TMB17 in TMB1 is cleared to 0, timer B1 functions as an 8-bit interval timer. Upon reset, TCB1 is cleared to H'00 and bit TMB17 is cleared to 0, so up-counting and interval timing resume immediately. The operating clock of timer B1 is selected from seven internal clock signals output by prescaler S. The selection is made by the TMB12 to TMB10 bits in TMB1.

After the count value in TMB1 reaches H'FF, the next clock signal input causes timer B1 to overflow, setting flag IRRTB1 in IRR2 to 1. If IENTB1 in IENR2 is 1, an interrupt is requested to the CPU.

At overflow, TCB1 returns to H'00 and starts counting up again. During interval timer operation (TMB17 = 0), when a value is set in TLB1, the same value is set in TCB1.

10.3.2 Auto-Reload Timer Operation

Setting bit TMB17 in TMB1 to 1 causes timer B1 to function as an 8-bit auto-reload timer. When a reload value is set in TLB1, the same value is loaded into TCB1, becoming the value from which TCB1 starts its count. After the count value in TCB1 reaches H'FF, the next clock signal input causes timer B1 to overflow. The TLB1 value is then loaded into TCB1, and the count continues from that value. The overflow period can be set within a range from 1 to 256 input clocks, depending on the TLB1 value.

The clock sources and interrupts in auto-reload mode are the same as in interval mode. In auto-reload mode (TMB17 = 1), when a new value is set in TLB1, the TLB1 value is also loaded into TCB1.

10.4 Timer B1 Operating Modes

Table 10.1 shows the timer B1 operating modes.

Table 10.1 Timer B1 Operating Modes

Operating Mode	Reset	Active	Sleep	Subsleep	Standby	
TCB1	Interval	Reset	Functions	Functions	Halted	Halted
	Auto-reload	Reset	Functions	Functions	Halted	Halted
TMB1	Reset	Functions	Retained	Retained	Retained	

Section 11 Timer V

Timer V is an 8-bit timer based on an 8-bit counter. Timer V counts external events. Compare-match signals with two registers can also be used to reset the counter, request an interrupt, or output a pulse signal with an arbitrary duty cycle. Counting can be initiated by a trigger input at the TRGV pin, enabling pulse output control to be synchronized to the trigger, with an arbitrary delay from the trigger input. Figure 11.1 shows a block diagram of timer V.

11.1 Features

- Choice of seven clock signals is available.
Choice of six internal clock sources ($\phi/128$, $\phi/64$, $\phi/32$, $\phi/16$, $\phi/8$, $\phi/4$) or an external clock.
- Counter can be cleared by compare match A or B, or by an external reset signal. If the count stop function is selected, the counter can be halted when cleared.
- Timer output is controlled by two independent compare match signals, enabling pulse output with an arbitrary duty cycle, PWM output, and other applications.
- Three interrupt sources: compare match A, compare match B, timer overflow
- Counting can be initiated by trigger input at the TRGV pin. The rising edge, falling edge, or both edges of the TRGV input can be selected.

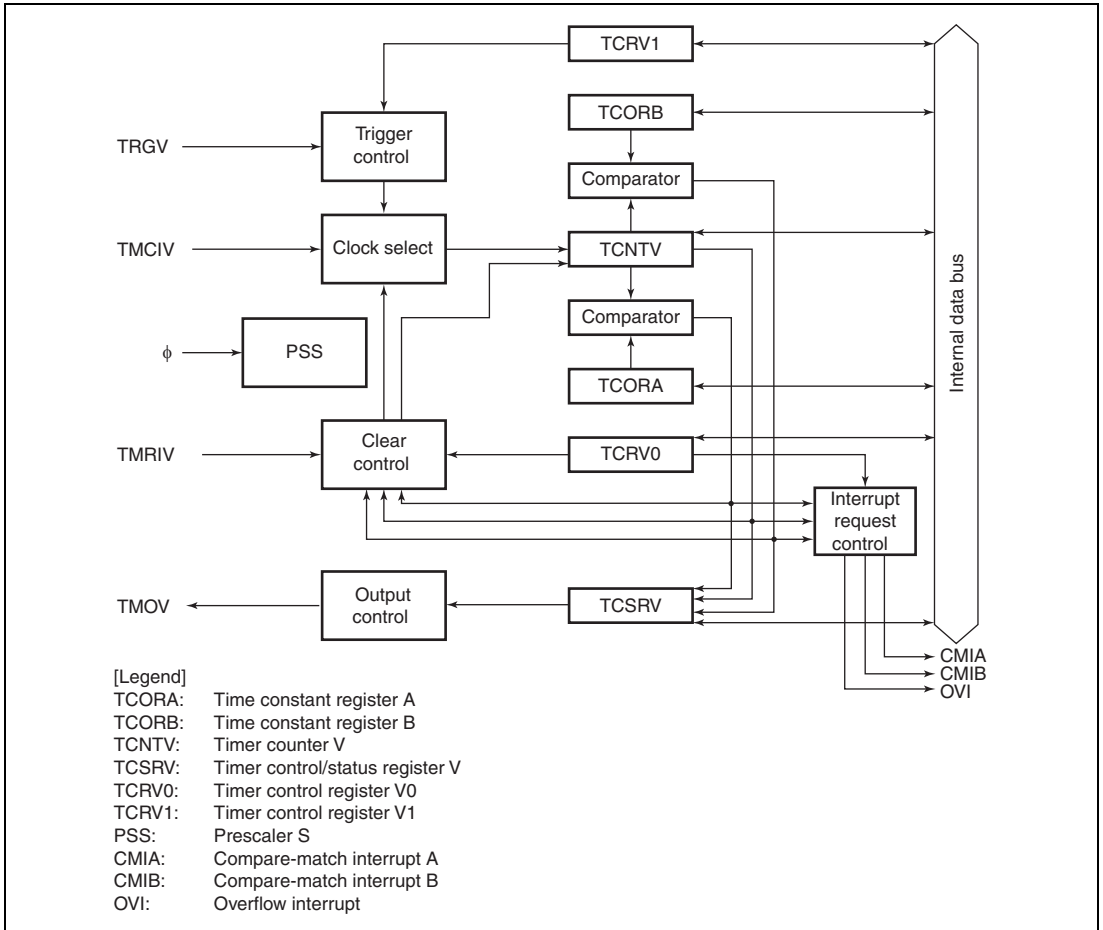

Figure 11.1 Block Diagram of Timer V

11.2 Input/Output Pins

Table 11.1 shows the timer V pin configuration.

Table 11.1 Pin Configuration

Name	Abbreviation	I/O	Function
Timer V output	TMOV	Output	Timer V waveform output
Timer V clock input	TMCIV	Input	Clock input to TCNTV
Timer V reset input	TMRIV	Input	External input to reset TCNTV
Trigger input	TRGV	Input	Trigger input to initiate counting

11.3 Register Descriptions

Time V has the following registers.

- Timer counter V (TCNTV)
- Timer constant register A (TCORA)
- Timer constant register B (TCORB)
- Timer control register V0 (TCRV0)
- Timer control/status register V (TCSR V)
- Timer control register V1 (TCRV1)

11.3.1 Timer Counter V (TCNTV)

TCNTV is an 8-bit up-counter. The clock source is selected by bits CKS2 to CKS0 in timer control register V0 (TCRV0). The TCNTV value can be read and written by the CPU at any time. TCNTV can be cleared by an external reset input signal, or by compare match A or B. The clearing signal is selected by bits CCLR1 and CCLR0 in TCRV0.

When TCNTV overflows, OVF is set to 1 in timer control/status register V (TCSR V).

TCNTV is initialized to H'00.

11.3.2 Time Constant Registers A and B (TCORA, TCORB)

TCORA and TCORB have the same function.

TCORA and TCORB are 8-bit read/write registers.

TCORA and TCNTV are compared at all times. When the TCORA and TCNTV contents match, CMFA is set to 1 in TCSR.V. If CMIEA is also set to 1 in TCR.V0, a CPU interrupt is requested. Note that they must not be compared during the T3 state of a TCORA write cycle.

Timer output from the TMOV pin can be controlled by the identifying signal (compare match A) and the settings of bits OS3 to OS0 in TCSR.V.

TCORA and TCORB are initialized to H'FF.

11.3.3 Timer Control Register V0 (TCRV0)

TCRV0 selects the input clock signals of TCNTV, specifies the clearing conditions of TCNTV, and controls each interrupt request.

Bit	Bit Name	Initial Value	R/W	Description
7	CMIEB	0	R/W	Compare Match Interrupt Enable B When this bit is set to 1, interrupt request from the CMFB bit in TCSR.V is enabled.
6	CMIEA	0	R/W	Compare Match Interrupt Enable A When this bit is set to 1, interrupt request from the CMFA bit in TCSR.V is enabled.
5	OVIE	0	R/W	Timer Overflow Interrupt Enable When this bit is set to 1, interrupt request from the OVF bit in TCSR.V is enabled.

Bit	Bit Name	Initial Value	R/W	Description
4	CCLR1	0	R/W	Counter Clear 1 and 0
3	CCLR0	0	R/W	These bits specify the clearing conditions of TCNTV. 00: Clearing is disabled 01: Cleared by compare match A 10: Cleared by compare match B 11: Cleared on the rising edge of the TMRIV pin. The operation of TCNTV after clearing depends on TRGE in TCRV1.
2	CKS2	0	R/W	Clock Select 2 to 0
1	CKS1	0	R/W	These bits select clock signals to input to TCNTV and the counting condition in combination with ICKS0 in TCRV1. Refer to table 11.2.
0	CKS0	0	R/W	

Table 11.2 Clock Signals to Input to TCNTV and Counting Conditions

TCRV0			TCRV1	Description
Bit 2	Bit 1	Bit 0	Bit 0	
CKS2	CKS1	CKS0	ICKS0	
0	0	0	—	Clock input prohibited
		1	0	Internal clock: counts on $\phi/4$, falling edge
			1	Internal clock: counts on $\phi/8$, falling edge
	1	0	0	Internal clock: counts on $\phi/16$, falling edge
			1	Internal clock: counts on $\phi/32$, falling edge
		1	0	Internal clock: counts on $\phi/64$, falling edge
		1	Internal clock: counts on $\phi/128$, falling edge	
1	0	0	—	Clock input prohibited
		1	—	External clock: counts on rising edge
	1	0	—	External clock: counts on falling edge
		1	—	External clock: counts on rising and falling edge

11.3.4 Timer Control/Status Register V (TCSR_V)

TCSR_V indicates the status flag and controls outputs by using a compare match.

Bit	Bit Name	Initial Value	R/W	Description
7	CMFB	0	R/W	Compare Match Flag B [Setting condition] <ul style="list-style-type: none"> When the TCNTV value matches the TCORB value [Clearing condition] <ul style="list-style-type: none"> After reading CMFB = 1, cleared by writing 0 to CMFB
6	CMFA	0	R/W	Compare Match Flag A [Setting condition] <ul style="list-style-type: none"> When the TCNTV value matches the TCORA value [Clearing condition] <ul style="list-style-type: none"> After reading CMFA = 1, cleared by writing 0 to CMFA
5	OVF	0	R/W	Timer Overflow Flag [Setting condition] <ul style="list-style-type: none"> When TCNTV overflows from H'FF to H'00 [Clearing condition] <ul style="list-style-type: none"> After reading OVF = 1, cleared by writing 0 to OVF
4	—	1	—	Reserved This bit is always read as 1.
3	OS3	0	R/W	Output Select 3 and 2
2	OS2	0	R/W	These bits select an output method for the TMOV pin by the compare match of TCORB and TCNTV. 00: No change 01: 0 output 10: 1 output 11: Output toggles

Bit	Bit Name	Initial Value	R/W	Description
1	OS1	0	R/W	Output Select 1 and 0
0	OS0	0	R/W	These bits select an output method for the TMOV pin by the compare match of TCORA and TCNTV. 00: No change 01: 0 output 10: 1 output 11: Output toggles

OS3 and OS2 select the output level for compare match B. OS1 and OS0 select the output level for compare match A. The two output levels can be controlled independently. After a reset, the timer output is 0 until the first compare match.

11.3.5 Timer Control Register V1 (TCRV1)

TCRV1 selects the edge at the TRGV pin, enables TRGV input, and selects the clock input to TCNTV.

Bit	Bit Name	Initial Value	R/W	Description
7 to 5	—	All 1	—	Reserved These bits are always read as 1.
4	TVEG1	0	R/W	TRGV Input Edge Select
3	TVEG0	0	R/W	These bits select the TRGV input edge. 00: TRGV trigger input is prohibited 01: Rising edge is selected 10: Falling edge is selected 11: Rising and falling edges are both selected
2	TRGE	0	R/W	TCNT starts counting up by the input of the edge which is selected by TVEG1 and TVEG0. 0: Disables starting counting-up TCNTV by the input of the TRGV pin and halting counting-up TCNTV when TCNTV is cleared by a compare match. 1: Enables starting counting-up TCNTV by the input of the TRGV pin and halting counting-up TCNTV when TCNTV is cleared by a compare match.

Bit	Bit Name	Initial Value	R/W	Description
1	—	1	—	Reserved This bit is always read as 1.
0	ICKS0	0	R/W	Internal Clock Select 0 This bit selects clock signals to input to TCNTV in combination with CKS2 to CKS0 in TCRV0. Refer to table 11.2.

11.4 Operation

11.4.1 Timer V Operation

1. According to table 11.2, six internal/external clock signals output by prescaler S can be selected as the timer V operating clock signals. When the operating clock signal is selected, TCNTV starts counting-up. Figure 11.2 shows the count timing with an internal clock signal selected, and figure 11.3 shows the count timing with both edges of an external clock signal selected.
2. When TCNTV overflows (changes from H'FF to H'00), the overflow flag (OVF) in TCRV0 will be set. The timing at this time is shown in figure 11.4. An interrupt request is sent to the CPU when OVIE in TCRV0 is 1.
3. TCNTV is constantly compared with TCORA and TCORB. Compare match flag A or B (CMFA or CMFB) is set to 1 when TCNTV matches TCORA or TCORB, respectively. The compare-match signal is generated in the last state in which the values match. Figure 11.5 shows the timing. An interrupt request is generated for the CPU when CMIEA or CMIEB in TCRV0 is 1.
4. When a compare match A or B is generated, the TMOV responds with the output value selected by bits OS3 to OS0 in TCSR.V. Figure 11.6 shows the timing when the output is toggled by compare match A.
5. When CCLR1 or CCLR0 in TCRV0 is 01 or 10, TCNTV can be cleared by the corresponding compare match. Figure 11.7 shows the timing.
6. When CCLR1 or CCLR0 in TCRV0 is 11, TCNTV can be cleared by the rising edge of the input of TMRIV pin. A TMRIV input pulse-width of at least 1.5 system clocks is necessary. Figure 11.8 shows the timing.
7. When a counter-clearing source is generated with TRGE in TCRV1 set to 1, the counting-up is halted as soon as TCNTV is cleared. TCNTV resumes counting-up when the edge selected by TVEG1 or TVEG0 in TCRV1 is input from the TGRV pin.

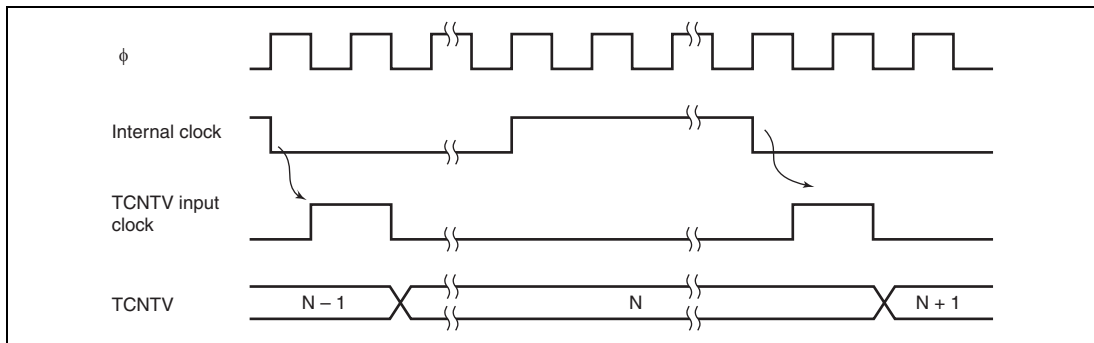

Figure 11.2 Increment Timing with Internal Clock

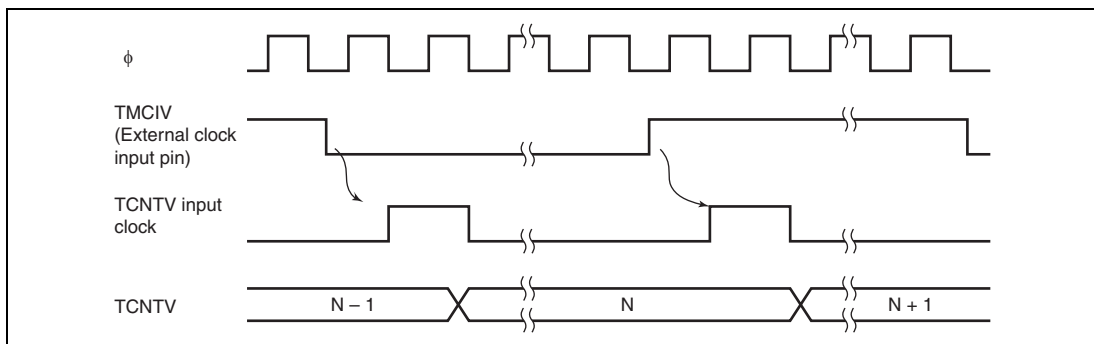

Figure 11.3 Increment Timing with External Clock

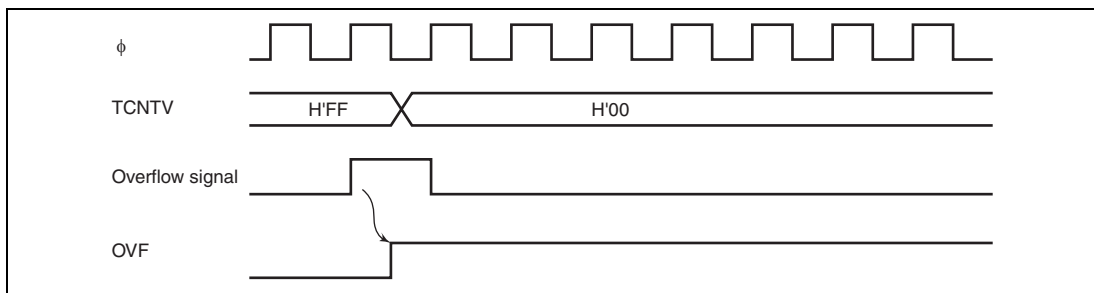

Figure 11.4 OVF Set Timing

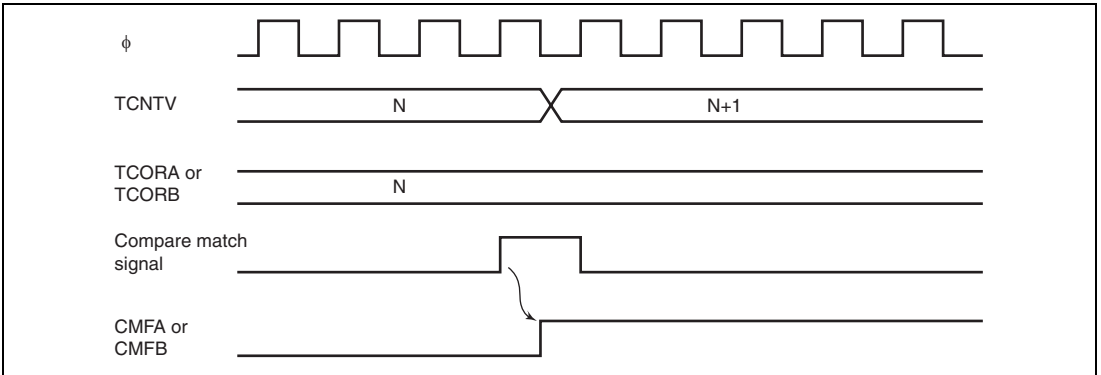

Figure 11.5 CMFA and CMFB Set Timing

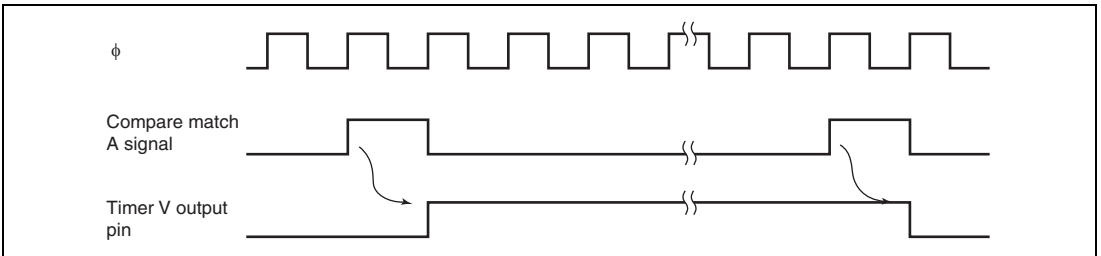

Figure 11.6 TMOV Output Timing

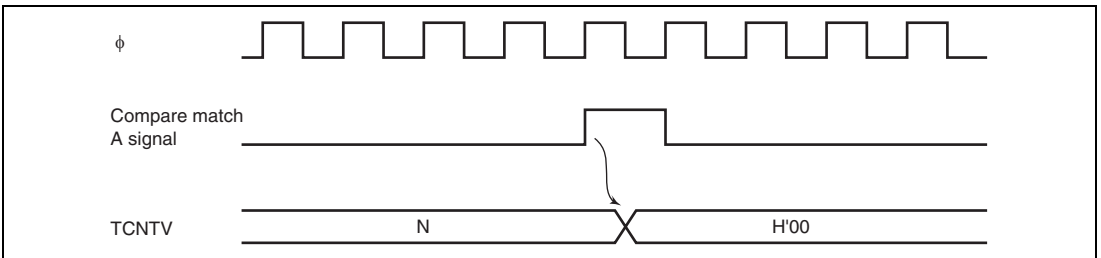

Figure 11.7 Clear Timing by Compare Match

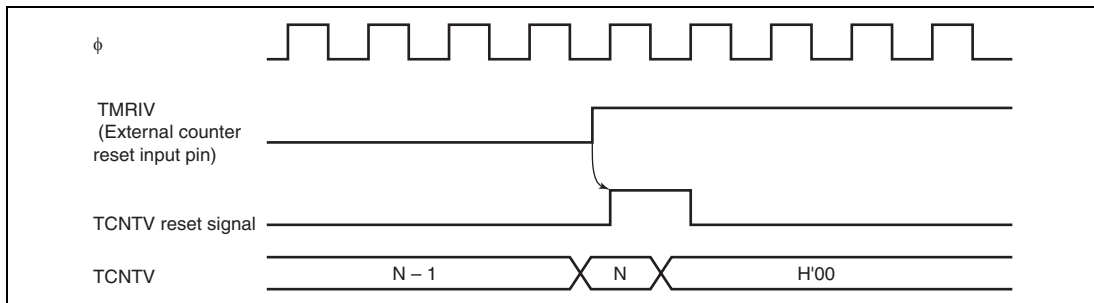

Figure 11.8 Clear Timing by TMRIV Input

11.5 Timer V Application Examples

11.5.1 Pulse Output with Arbitrary Duty Cycle

Figure 11.9 shows an example of output of pulses with an arbitrary duty cycle.

1. Set bits CCLR1 and CCLR0 in TCRV0 so that TCNTV will be cleared by compare match with TCORA.
2. Set bits OS3 to OS0 in TCSR0V so that the output will go to 1 at compare match with TCORA and to 0 at compare match with TCORB.
3. Set bits CKS2 to CKS0 in TCRV0 and bit ICKS0 in TCRV1 to select the desired clock source.
4. With these settings, a waveform is output without further software intervention, with a period determined by TCORA and a pulse width determined by TCORB.

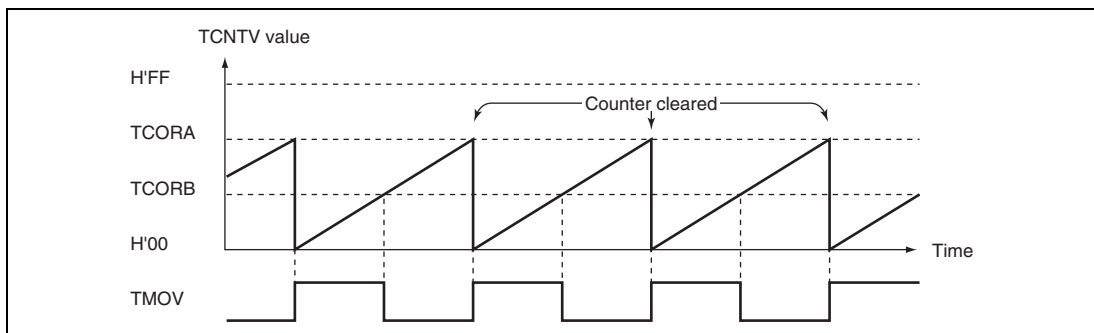

Figure 11.9 Pulse Output Example

11.5.2 Pulse Output with Arbitrary Pulse Width and Delay from TRGV Input

The trigger function can be used to output a pulse with an arbitrary pulse width at an arbitrary delay from the TRGV input, as shown in figure 11.10. To set up this output:

1. Set bits CCLR1 and CCLR0 in TCRV0 so that TCNTV will be cleared by compare match with TCORB.
2. Set bits OS3 to OS0 in TCSRV so that the output will go to 1 at compare match with TCORA and to 0 at compare match with TCORB.
3. Set bits TVEG1 and TVEG0 in TCRV1 and set TRGE to select the falling edge of the TRGV input.
4. Set bits CKS2 to CKS0 in TCRV0 and bit ICKS0 in TCRV1 to select the desired clock source.
5. After these settings, a pulse waveform will be output without further software intervention, with a delay determined by TCORA from the TRGV input, and a pulse width determined by (TCORB to TCORA).

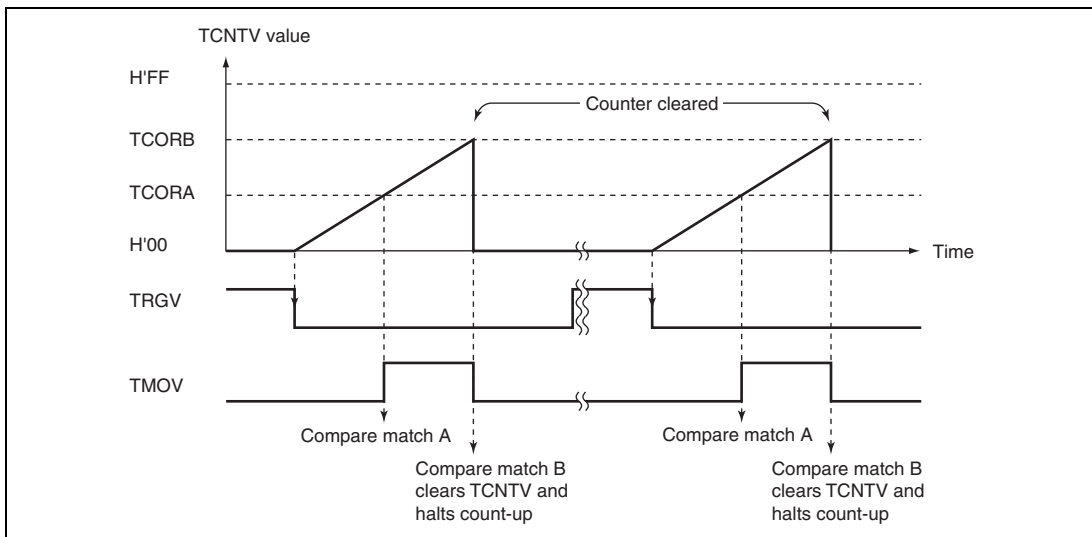

Figure 11.10 Example of Pulse Output Synchronized to TRGV Input

11.6 Usage Notes

The following types of contention or operation can occur in timer V operation.

1. Writing to registers is performed in the T3 state of a TCNTV write cycle. If a TCNTV clear signal is generated in the T3 state of a TCNTV write cycle, as shown in figure 11.11, clearing takes precedence and the write to the counter is not carried out. If counting-up is generated in the T3 state of a TCNTV write cycle, writing takes precedence.
2. If a compare match is generated in the T3 state of a TCORA or TCORB write cycle, the write to TCORA or TCORB takes precedence and the compare match signal is inhibited. Figure 11.12 shows the timing.
3. If compare matches A and B occur simultaneously, any conflict between the output selections for compare match A and compare match B is resolved by the following priority: toggle output > output 1 > output 0.
4. Depending on the timing, TCNTV may be incremented by a switch between different internal clock sources. When TCNTV is internally clocked, an increment pulse is generated from the falling edge of an internal clock signal, that is divided system clock (ϕ). Therefore, as shown in figure 11.13 the switch is from a high clock signal to a low clock signal, the switchover is seen as a falling edge, causing TCNTV to increment. TCNTV can also be incremented by a switch between internal and external clocks.

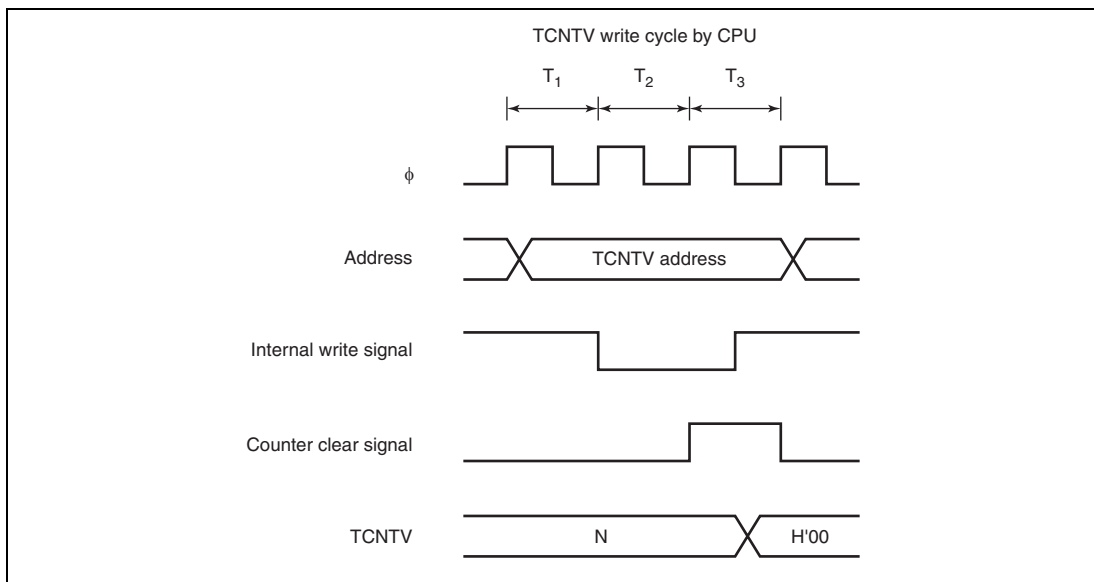

Figure 11.11 Contention between TCNTV Write and Clear

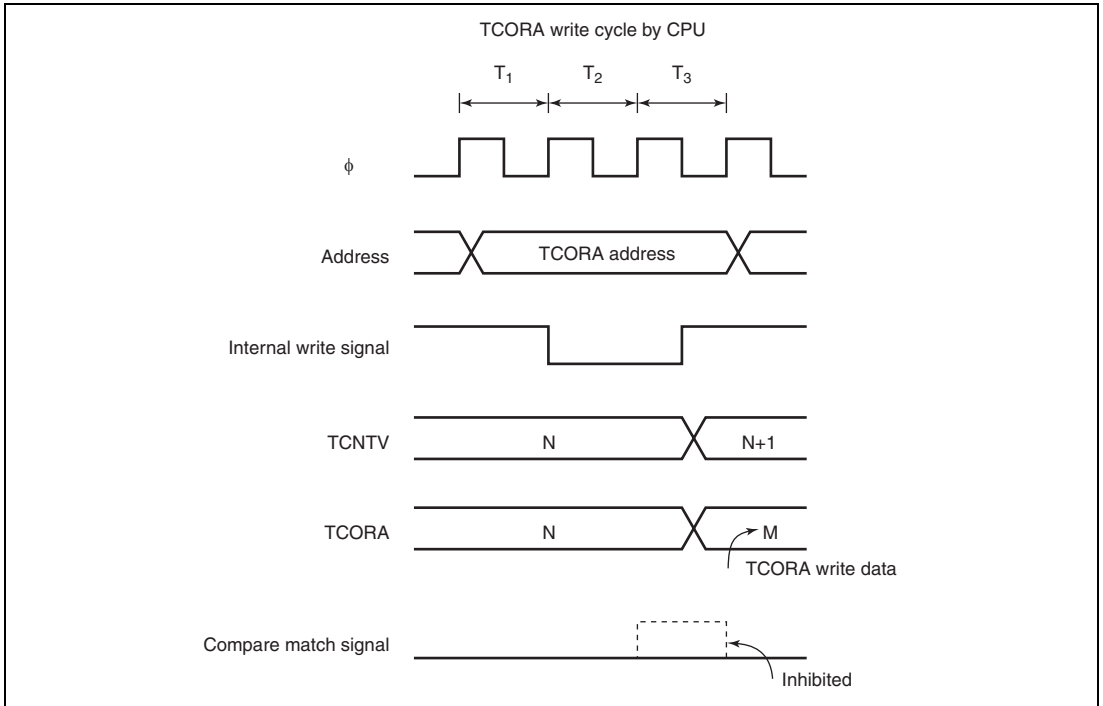

Figure 11.12 Contention between TCORA Write and Compare Match

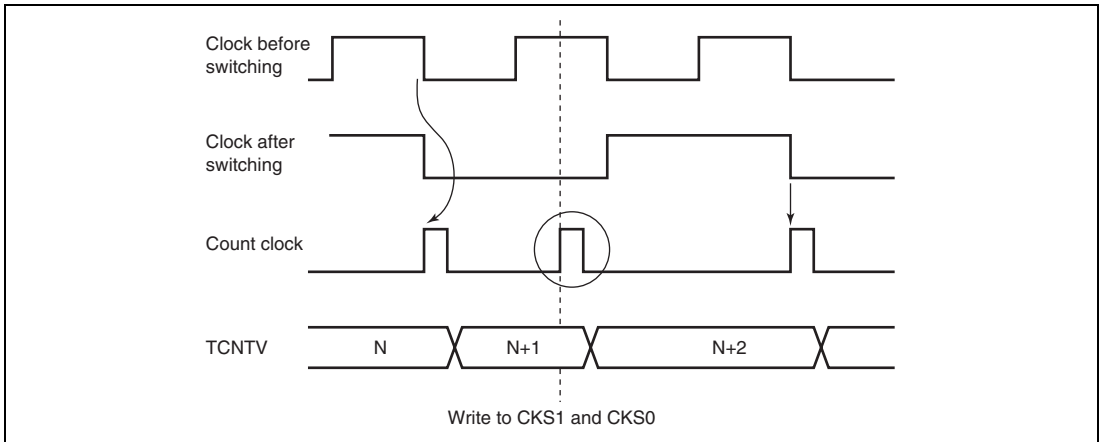

Figure 11.13 Internal Clock Switching and TCNTV Operation

Section 12 Timer W

The timer W has a 16-bit timer having output compare and input capture functions. The timer W can count external events and output pulses with an arbitrary duty cycle by compare match between the timer counter and four general registers. Thus, it can be applied to various systems.

12.1 Features

- Selection of five counter clock sources: four internal clocks (ϕ , $\phi/2$, $\phi/4$, and $\phi/8$) and an external clock (external events can be counted)
- Capability to process up to four pulse outputs or four pulse inputs
- Four general registers:
 - Independently assignable output compare or input capture functions
 - Usable as two pairs of registers; one register of each pair operates as a buffer for the output compare or input capture register
- Four selectable operating modes:
 - Waveform output by compare match
 - Selections of 0 output, 1 output, or toggle output
 - Input capture function
 - Rising edge, falling edge, or both edges
 - Counter clearing function
 - Counters can be cleared by compare match
 - PWM mode
 - Up to three-phase PWM output can be provided with desired duty ratio.
- Any initial timer output value can be set
- Five interrupt sources
 - Four compare match/input capture interrupts and an overflow interrupt.

Table 12.1 summarizes the timer W functions, and figure 12.1 shows a block diagram of the timer W.

Table 12.1 Timer W Functions

Item	Counter	Input/Output Pins			
		FTIOA	FTIOB	FTIOC	FTIOD
Count clock	Internal clocks: ϕ , $\phi/2$, $\phi/4$, $\phi/8$ External clock: FTCl				
General registers (output compare/input capture registers)	Period specified in GRA	GRA	GRB	GRC (buffer register for GRA in buffer mode)	GRD (buffer register for GRB in buffer mode)
Counter clearing function	GRA compare match	GRA compare match	—	—	—
Initial output value setting function	—	Yes	Yes	Yes	Yes
Buffer function	—	Yes	Yes	—	—
Compare match output	0	—	Yes	Yes	Yes
	1	—	Yes	Yes	Yes
	Toggle	—	Yes	Yes	Yes
Input capture function	—	Yes	Yes	Yes	Yes
PWM mode	—	—	Yes	Yes	Yes
Interrupt sources	Overflow	Compare match/input capture	Compare match/input capture	Compare match/input capture	Compare match/input capture

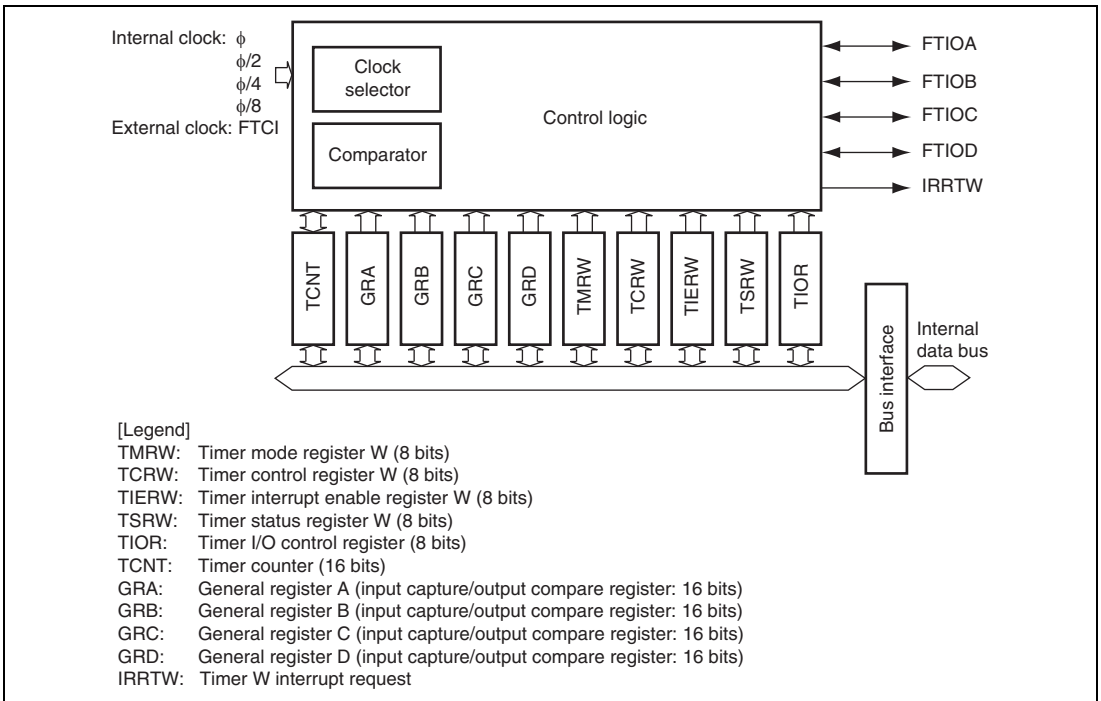

Figure 12.1 Timer W Block Diagram

12.2 Input/Output Pins

Table 12.2 summarizes the timer W pins.

Table 12.2 Pin Configuration

Name	Abbreviation	Input/Output	Function
External clock input	FTCI	Input	External clock input pin
Input capture/output compare A	FTIOA	Input/output	Output pin for GRA output compare or input pin for GRA input capture
Input capture/output compare B	FTIOB	Input/output	Output pin for GRB output compare, input pin for GRB input capture, or PWM output pin in PWM mode
Input capture/output compare C	FTIOC	Input/output	Output pin for GRC output compare, input pin for GRC input capture, or PWM output pin in PWM mode
Input capture/output compare D	FTIOD	Input/output	Output pin for GRD output compare, input pin for GRD input capture, or PWM output pin in PWM mode

12.3 Register Descriptions

The timer W has the following registers.

- Timer mode register W (TMRW)
- Timer control register W (TCRW)
- Timer interrupt enable register W (TIERW)
- Timer status register W (TSRW)
- Timer I/O control register 0 (TIOR0)
- Timer I/O control register 1 (TIOR1)
- Timer counter (TCNT)
- General register A (GRA)
- General register B (GRB)
- General register C (GRC)
- General register D (GRD)

12.3.1 Timer Mode Register W (TMRW)

TMRW selects the general register functions and the timer output mode.

Bit	Bit Name	Initial Value	R/W	Description
7	CTS	0	R/W	Counter Start The counter operation is halted when this bit is 0, while it can be performed when this bit is 1.
6	—	1	—	Reserved This bit is always read as 1.
5	BUFEB	0	R/W	Buffer Operation B Selects the GRD function. 0: GRD operates as an input capture/output compare register 1: GRD operates as the buffer register for GRB
4	BUFEA	0	R/W	Buffer Operation A Selects the GRC function. 0: GRC operates as an input capture/output compare register 1: GRC operates as the buffer register for GRA
3	—	1	—	Reserved This bit is always read as 1.
2	PWMD	0	R/W	PWM Mode D Selects the output mode of the FTIOD pin. 0: FTIOD operates normally (output compare output) 1: PWM output
1	PWMC	0	R/W	PWM Mode C Selects the output mode of the FTIOC pin. 0: FTIOC operates normally (output compare output) 1: PWM output
0	PWMB	0	R/W	PWM Mode B Selects the output mode of the FTIOB pin. 0: FTIOB operates normally (output compare output) 1: PWM output

12.3.2 Timer Control Register W (TCRW)

TCRW selects the timer counter clock source, selects a clearing condition, and specifies the timer output levels.

Bit	Bit Name	Initial Value	R/W	Description
7	CCLR	0	R/W	Counter Clear The TCNT value is cleared by compare match A when this bit is 1. When it is 0, TCNT operates as a free-running counter.
6	CKS2	0	R/W	Clock Select 2 to 0
5	CKS1	0	R/W	Select the TCNT clock source.
4	CKS0	0	R/W	000: Internal clock: counts on ϕ 001: Internal clock: counts on $\phi/2$ 010: Internal clock: counts on $\phi/4$ 011: Internal clock: counts on $\phi/8$ 1XX: Counts on rising edges of the external event (FTCI) When the internal clock source (ϕ) is selected, subclock sources are counted in subactive and subsleep modes.
3	TOD	0	R/W	Timer Output Level Setting D Sets the output value of the FTIOD pin until the first compare match D is generated. 0: Output value is 0* 1: Output value is 1*
2	TOC	0	R/W	Timer Output Level Setting C Sets the output value of the FTIOC pin until the first compare match C is generated. 0: Output value is 0* 1: Output value is 1*
1	TOB	0	R/W	Timer Output Level Setting B Sets the output value of the FTIOB pin until the first compare match B is generated. 0: Output value is 0* 1: Output value is 1*

Bit	Bit Name	Initial Value	R/W	Description
0	TOA	0	R/W	Timer Output Level Setting A Sets the output value of the FTIOA pin until the first compare match A is generated. 0: Output value is 0* 1: Output value is 1*

[Legend]

X: Don't care

Note: * The change of the setting is immediately reflected in the output value.

12.3.3 Timer Interrupt Enable Register W (TIERW)

TIERW controls the timer W interrupt request.

Bit	Bit Name	Initial Value	R/W	Description
7	OVIE	0	R/W	Timer Overflow Interrupt Enable When this bit is set to 1, FOVI interrupt requested by OVF flag in TSRW is enabled.
6 to 4	—	All 1	—	Reserved These bits are always read as 1.
3	IMIED	0	R/W	Input Capture/Compare Match Interrupt Enable D When this bit is set to 1, IMID interrupt requested by IMFD flag in TSRW is enabled.
2	IMIEC	0	R/W	Input Capture/Compare Match Interrupt Enable C When this bit is set to 1, IMIC interrupt requested by IMFC flag in TSRW is enabled.
1	IMIEB	0	R/W	Input Capture/Compare Match Interrupt Enable B When this bit is set to 1, IMIB interrupt requested by IMFB flag in TSRW is enabled.
0	IMIEA	0	R/W	Input Capture/Compare Match Interrupt Enable A When this bit is set to 1, IMIA interrupt requested by IMFA flag in TSRW is enabled.

12.3.4 Timer Status Register W (TSRW)

TSRW shows the status of interrupt requests.

Bit	Bit Name	Initial Value	R/W	Description
7	OVF	0	R/W	Timer Overflow Flag [Setting condition] <ul style="list-style-type: none"> When TCNT overflows from H'FFFF to H'0000 [Clearing condition] <ul style="list-style-type: none"> Read OVF when OVF = 1, then write 0 in OVF
6 to 4	—	All 1	—	Reserved These bits are always read as 1.
3	IMFD	0	R/W	Input Capture/Compare Match Flag D [Setting conditions] <ul style="list-style-type: none"> TCNT = GRD when GRD functions as an output compare register The TCNT value is transferred to GRD by an input capture signal when GRD functions as an input capture register [Clearing condition] <ul style="list-style-type: none"> Read IMFD when IMFD = 1, then write 0 in IMFD
2	IMFC	0	R/W	Input Capture/Compare Match Flag C [Setting conditions] <ul style="list-style-type: none"> TCNT = GRC when GRC functions as an output compare register The TCNT value is transferred to GRC by an input capture signal when GRC functions as an input capture register [Clearing condition] <ul style="list-style-type: none"> Read IMFC when IMFC = 1, then write 0 in IMFC

Bit	Bit Name	Initial Value	R/W	Description
1	IMFB	0	R/W	Input Capture/Compare Match Flag B [Setting conditions] <ul style="list-style-type: none"> • TCNT = GRB when GRB functions as an output compare register • The TCNT value is transferred to GRB by an input capture signal when GRB functions as an input capture register [Clearing condition] <ul style="list-style-type: none"> • Read IMFB when IMFB = 1, then write 0 in IMFB
0	IMFA	0	R/W	Input Capture/Compare Match Flag A [Setting conditions] <ul style="list-style-type: none"> • TCNT = GRA when GRA functions as an output compare register • The TCNT value is transferred to GRA by an input capture signal when GRA functions as an input capture register [Clearing condition] <ul style="list-style-type: none"> • Read IMFA when IMFA = 1, then write 0 in IMFA

12.3.5 Timer I/O Control Register 0 (TIOR0)

TIOR0 selects the functions of GRA and GRB, and specifies the functions of the FTIOA and FTIOB pins.

Bit	Bit Name	Initial Value	R/W	Description
7	—	1	—	Reserved This bit is always read as 1.
6	IOB2	0	R/W	I/O Control B2 Selects the GRB function. 0: GRB functions as an output compare register 1: GRB functions as an input capture register
5	IOB1	0	R/W	I/O Control B1 and B0
4	IOB0	0	R/W	When IOB2 = 0, 00: No output at compare match 01: 0 output to the FTIOB pin at GRB compare match 10: 1 output to the FTIOB pin at GRB compare match 11: Output toggles to the FTIOB pin at GRB compare match When IOB2 = 1, 00: Input capture at rising edge at the FTIOB pin 01: Input capture at falling edge at the FTIOB pin 1X: Input capture at rising and falling edges of the FTIOB pin
3	—	1	—	Reserved This bit is always read as 1.
2	IOA2	0	R/W	I/O Control A2 Selects the GRA function. 0: GRA functions as an output compare register 1: GRA functions as an input capture register

Bit	Bit Name	Initial Value	R/W	Description
1	IOA1	0	R/W	I/O Control A1 and A0
0	IOA0	0	R/W	When IOA2 = 0, 00: No output at compare match 01: 0 output to the FTIOA pin at GRA compare match 10: 1 output to the FTIOA pin at GRA compare match 11: Output toggles to the FTIOA pin at GRA compare match When IOA2 = 1, 00: Input capture at rising edge of the FTIOA pin 01: Input capture at falling edge of the FTIOA pin 1X: Input capture at rising and falling edges of the FTIOA pin

[Legend]

X: Don't care

12.3.6 Timer I/O Control Register 1 (TIOR1)

TIOR1 selects the functions of GRC and GRD, and specifies the functions of the FTIOC and FTIOD pins.

Bit	Bit Name	Initial Value	R/W	Description
7	—	1	—	Reserved This bit is always read as 1.
6	IOD2	0	R/W	I/O Control D2 Selects the GRD function. 0: GRD functions as an output compare register 1: GRD functions as an input capture register When GRB buffer operation has been selected by BUFEB in TMRW, select the same function as GRB.

Bit	Bit Name	Initial Value	R/W	Description
5	IOD1	0	R/W	I/O Control D1 and D0
4	IOD0	0	R/W	When IOD2 = 0, 00: No output at compare match 01: 0 output to the FTIOD pin at GRD compare match 10: 1 output to the FTIOD pin at GRD compare match 11: Output toggles to the FTIOD pin at GRD compare match When IOD2 = 1, 00: Input capture at rising edge at the FTIOD pin 01: Input capture at falling edge at the FTIOD pin 1X: Input capture at rising and falling edges at the FTIOD pin
3	—	1	—	Reserved This bit is always read as 1.
2	IOC2	0	R/W	I/O Control C2 Selects the GRC function. 0: GRC functions as an output compare register 1: GRC functions as an input capture register When GRA buffer operation has been selected by BUFEA in TMRW, select the same function as GRA.
1	IOC1	0	R/W	I/O Control C1 and C0
0	IOC0	0	R/W	When IOC2 = 0, 00: No output at compare match 01: 0 output to the FTIOC pin at GRC compare match 10: 1 output to the FTIOC pin at GRC compare match 11: Output toggles to the FTIOC pin at GRC compare match When IOC2 = 1, 00: Input capture to GRC at rising edge of the FTIOC pin 01: Input capture to GRC at falling edge of the FTIOC pin 1X: Input capture to GRC at rising and falling edges of the FTIOC pin

[Legend]

X: Don't care

12.3.7 Timer Counter (TCNT)

TCNT is a 16-bit readable/writable up-counter. The clock source is selected by bits CKS2 to CKS0 in TCRW. TCNT can be cleared to H'0000 through a compare match with GRA by setting the CCLR in TCRW to 1. When TCNT overflows (changes from H'FFFF to H'0000), the OVF flag in TSRW is set to 1. If OVIE in TIERW is set to 1 at this time, an interrupt request is generated. TCNT must always be read or written in 16-bit units; 8-bit access is not allowed. TCNT is initialized to H'0000 by a reset.

12.3.8 General Registers A to D (GRA to GRD)

Each general register is a 16-bit readable/writable register that can function as either an output-compare register or an input-capture register. The function is selected by settings in TIOR0 and TIOR1.

When a general register is used as an input-compare register, its value is constantly compared with the TCNT value. When the two values match (a compare match), the corresponding flag (IMFA, IMFB, IMFC, or IMFD) in TSRW is set to 1. An interrupt request is generated at this time, when IMIEA, IMIEB, IMIEC, or IMIED is set to 1. Compare match output can be selected in TIOR.

When a general register is used as an input-capture register, an external input-capture signal is detected and the current TCNT value is stored in the general register. The corresponding flag (IMFA, IMFB, IMFC, or IMFD) in TSRW is set to 1. If the corresponding interrupt-enable bit (IMIEA, IMIEB, IMIEC, or IMIED) in TSRW is set to 1 at this time, an interrupt request is generated. The edge of the input-capture signal is selected in TIOR.

GRC and GRD can be used as buffer registers of GRA and GRB, respectively, by setting BUFEA and BUFEB in TMRW.

For example, when GRA is set as an output-compare register and GRC is set as the buffer register for GRA, the value in the buffer register GRC is sent to GRA whenever compare match A is generated.

When GRA is set as an input-capture register and GRC is set as the buffer register for GRA, the value in TCNT is transferred to GRA and the value in the buffer register GRC is transferred to GRA whenever an input capture is generated.

GRA to GRD must be written or read in 16-bit units; 8-bit access is not allowed. GRA to GRD are initialized to H'FFFF by a reset.

12.4 Operation

The timer W has the following operating modes.

- Normal Operation
- PWM Operation

12.4.1 Normal Operation

TCNT performs free-running or periodic counting operations. After a reset, TCNT is set as a free-running counter. When the CTS bit in TMRW is set to 1, TCNT starts incrementing the count. When the count overflows from H'FFFF to H'0000, the OVF flag in TSRW is set to 1. If the OVIE in TIERW is set to 1, an interrupt request is generated. Figure 12.2 shows free-running counting.

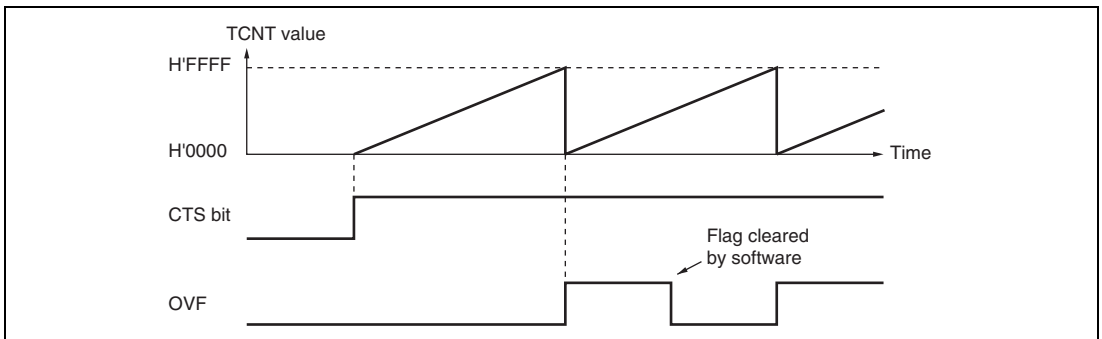

Figure 12.2 Free-Running Counter Operation

Periodic counting operation can be performed when GRA is set as an output compare register and bit CCLR in TCRW is set to 1. When the count matches GRA, TCNT is cleared to H'0000, the IMFA flag in TSRW is set to 1. If the corresponding IMIEA bit in TIERW is set to 1, an interrupt request is generated. TCNT continues counting from H'0000. Figure 12.3 shows periodic counting.

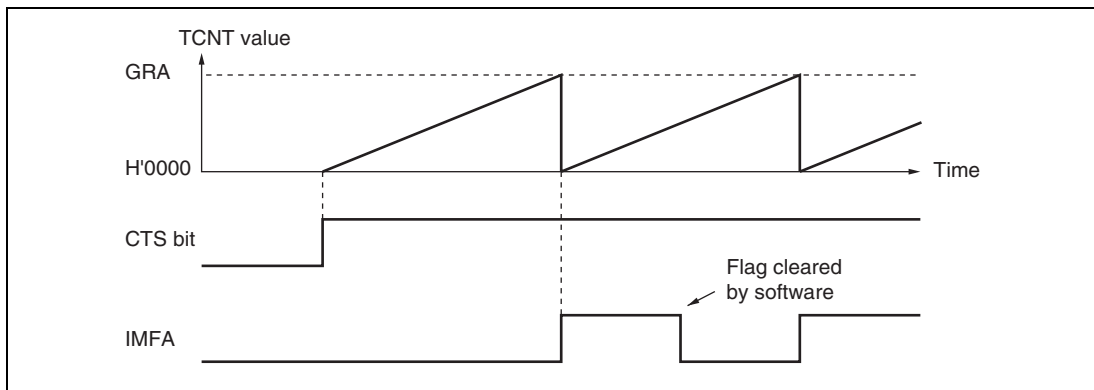

Figure 12.3 Periodic Counter Operation

By setting a general register as an output compare register, compare match A, B, C, or D can cause the output at the FTIOA, FTIOB, FTIOC, or FTIOD pin to output 0, output 1, or toggle. Figure 12.4 shows an example of 0 and 1 output when TCNT operates as a free-running counter, 1 output is selected for compare match A, and 0 output is selected for compare match B. When signal is already at the selected output level, the signal level does not change at compare match.

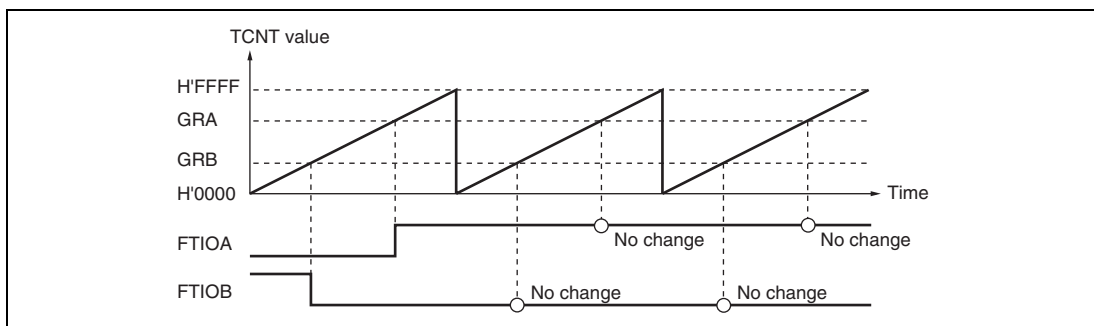

Figure 12.4 0 and 1 Output Example (TOA = 0, TOB = 1)

Figure 12.5 shows an example of toggle output when TCNT operates as a free-running counter, and toggle output is selected for both compare match A and B.

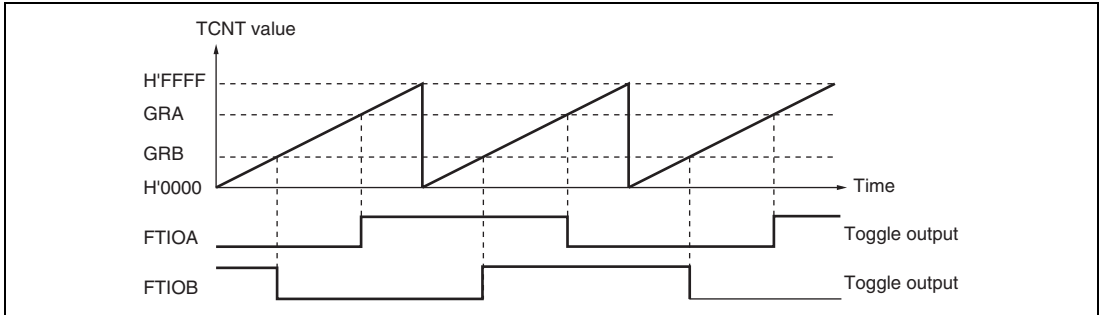

Figure 12.5 Toggle Output Example (TOA = 0, TOB = 1)

Figure 12.6 shows another example of toggle output when TCNT operates as a periodic counter, cleared by compare match A. Toggle output is selected for both compare match A and B.

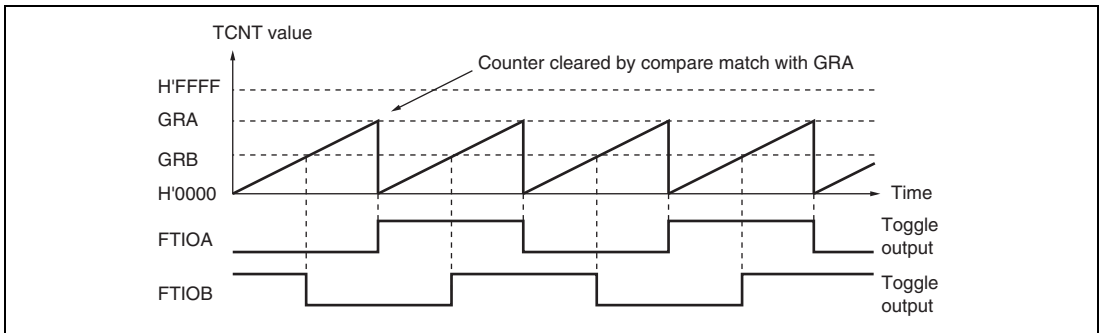

Figure 12.6 Toggle Output Example (TOA = 0, TOB = 1)

The TCNT value can be captured into a general register (GRA, GRB, GRC, or GRD) when a signal level changes at an input-capture pin (FTIOA, FTIOB, FTIOC, or FTIOD). Capture can take place on the rising edge, falling edge, or both edges. By using the input-capture function, the pulse width and periods can be measured. Figure 12.7 shows an example of input capture when both edges of FTIOA and the falling edge of FTIOB are selected as capture edges. TCNT operates as a free-running counter.

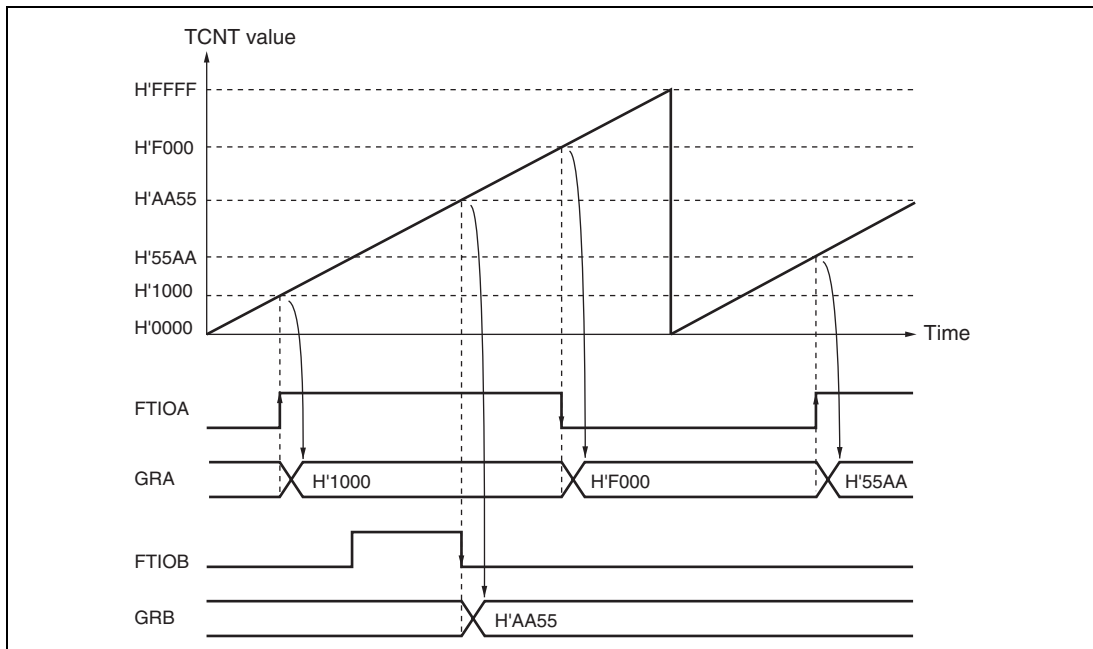

Figure 12.7 Input Capture Operating Example

Figure 12.8 shows an example of buffer operation when the GRA is set as an input-capture register and GRC is set as the buffer register for GRA. TCNT operates as a free-running counter, and FTIOA captures both rising and falling edge of the input signal. Due to the buffer operation, the GRA value is transferred to GRC by input-capture A and the TCNT value is stored in GRA.

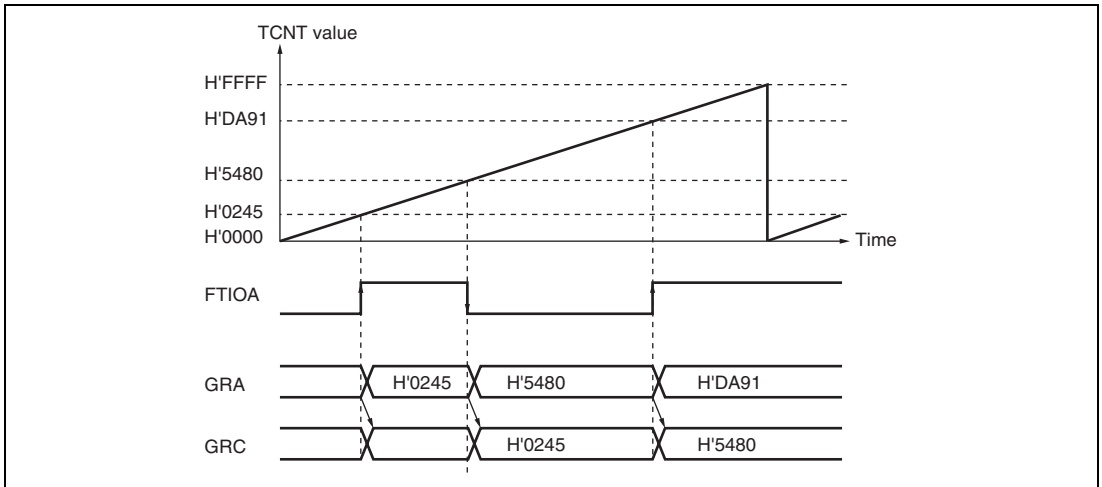

Figure 12.8 Buffer Operation Example (Input Capture)

12.4.2 PWM Operation

In PWM mode, PWM waveforms are generated by using GRA as the period register and GRB, GRC, and GRD as duty registers. PWM waveforms are output from the FTIOB, FTIOC, and FTIOD pins. Up to three-phase PWM waveforms can be output. In PWM mode, a general register functions as an output compare register automatically. The output level of each pin depends on the corresponding timer output level set bit (TOB, TOC, and TOD) in TCRW. When TOB is 1, the FTIOB output goes to 1 at compare match A and to 0 at compare match B. When TOB is 0, the FTIOB output goes to 0 at compare match A and to 1 at compare match B. Thus the compare match output level settings in TIOR0 and TIOR1 are ignored for the output pin set to PWM mode. If the same value is set in the cycle register and the duty register, the output does not change when a compare match occurs.

Figure 12.9 shows an example of operation in PWM mode. The output signals go to 1 and TCNT is cleared at compare match A, and the output signals go to 0 at compare match B, C, and D (TOB, TOC, and TOD = 1: initial output values are set to 1).

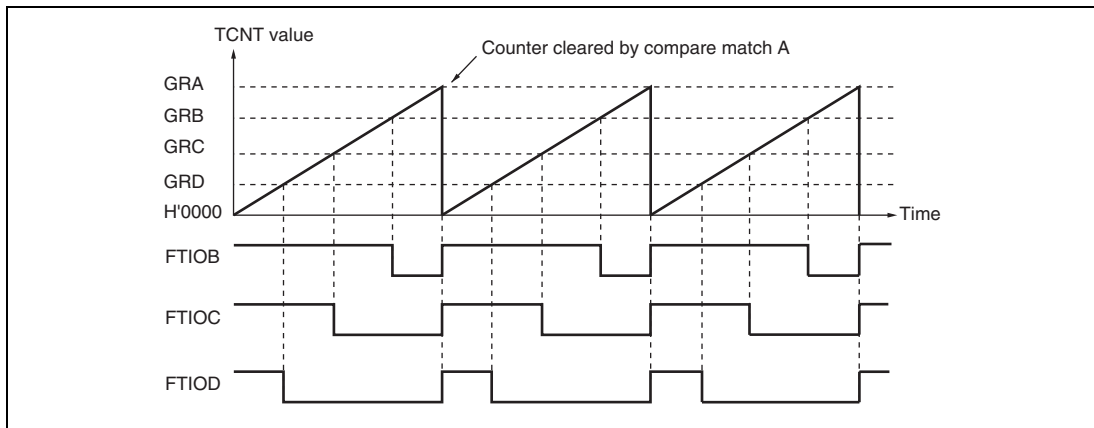

Figure 12.9 PWM Mode Example (1)

Figure 12.10 shows another example of operation in PWM mode. The output signals go to 0 and TCNT is cleared at compare match A, and the output signals go to 1 at compare match B, C, and D (TOB, TOC, and TOD = 0: initial output values are set to 1).

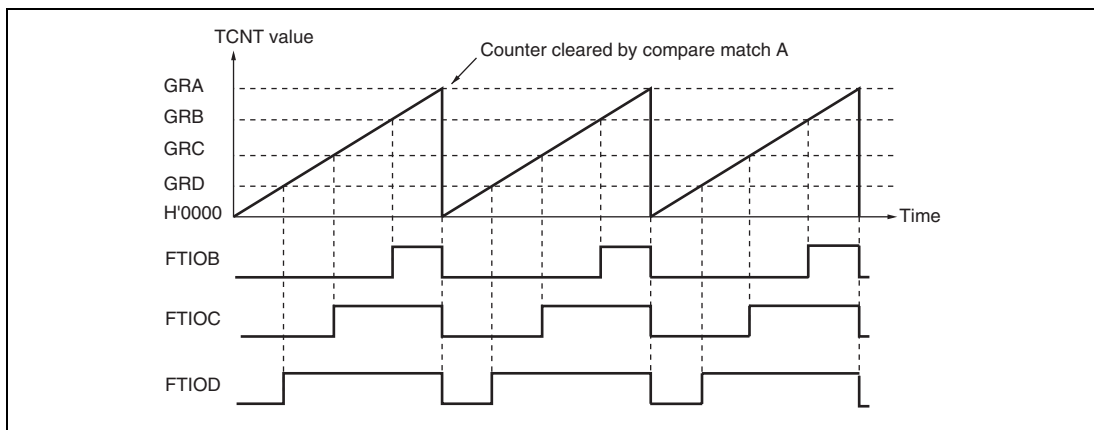

Figure 12.10 PWM Mode Example (2)

Figure 12.11 shows an example of buffer operation when the FTIOB pin is set to PWM mode and GRB is set as the buffer register for GRB. TCNT is cleared by compare match A, and FTIOB outputs 1 at compare match B and 0 at compare match A.

Due to the buffer operation, the FTIOB output level changes and the value of buffer register GRD is transferred to GRB whenever compare match B occurs. This procedure is repeated every time compare match B occurs.

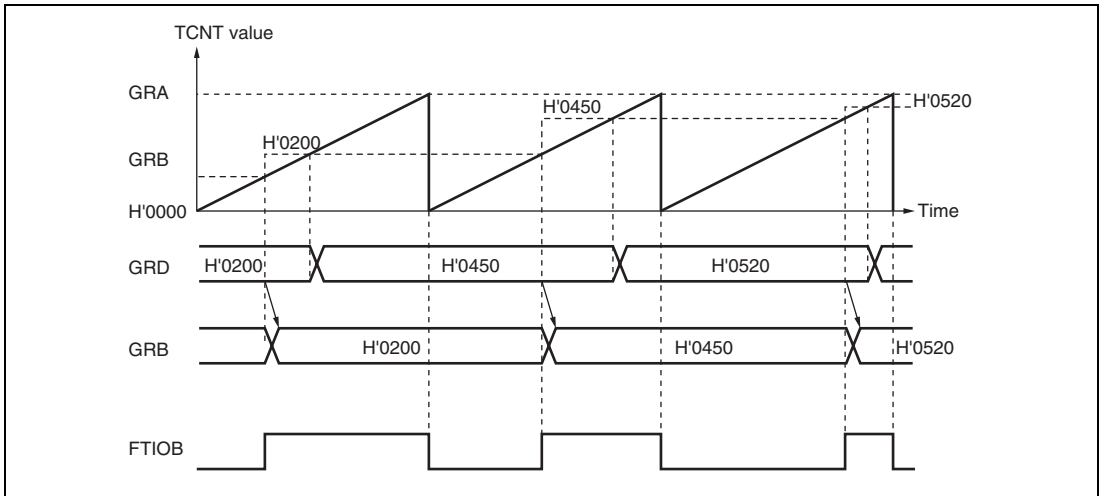

Figure 12.11 Buffer Operation Example (Output Compare)

Figures 12.12 and 12.13 show examples of the output of PWM waveforms with duty cycles of 0% and 100%.

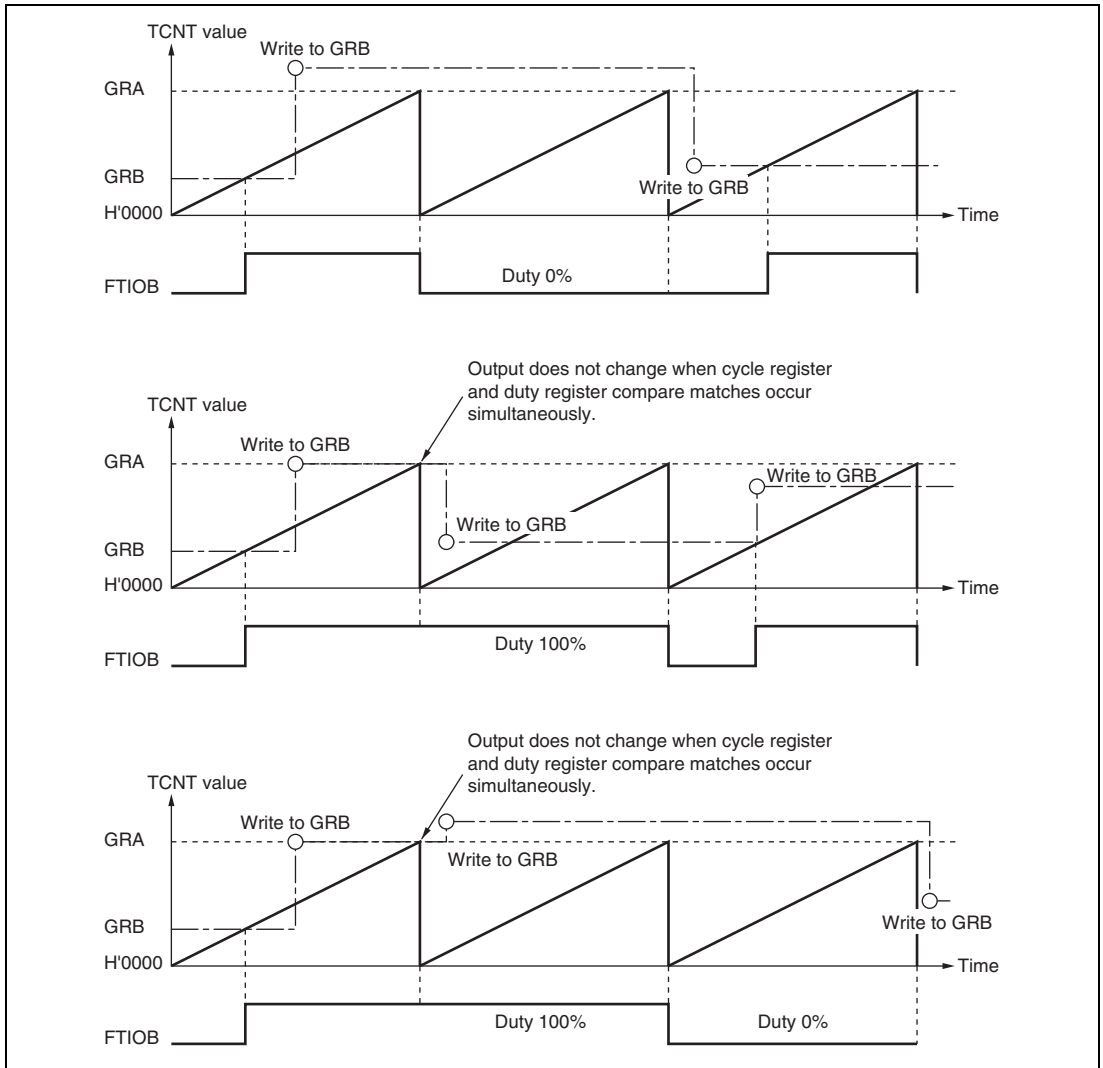

Figure 12.12 PWM Mode Example
(TOB, TOC, and TOD = 0: Initial Output Values are Set to 0)

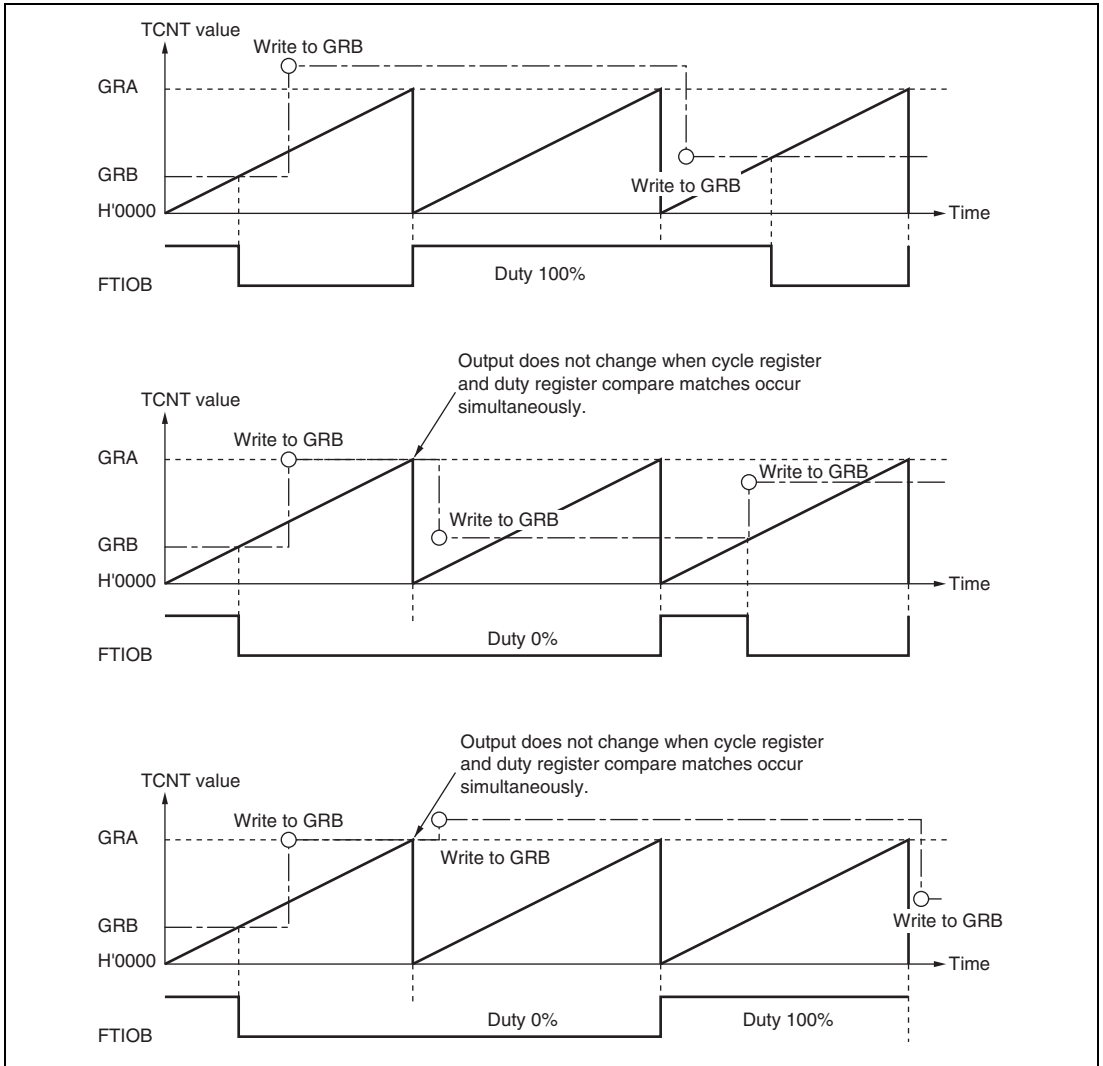

Figure 12.13 PWM Mode Example
(TOB, TOC, and TOD = 1: Initial Output Values are Set to 1)

12.5 Operation Timing

12.5.1 TCNT Count Timing

Figure 12.14 shows the TCNT count timing when the internal clock source is selected. Figure 12.15 shows the timing when the external clock source is selected. The pulse width of the external clock signal must be at least two system clock (ϕ) cycles; shorter pulses will not be counted correctly.

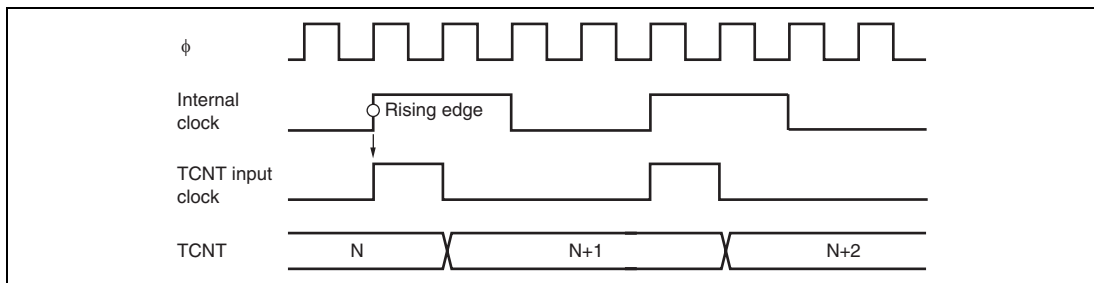

Figure 12.14 Count Timing for Internal Clock Source

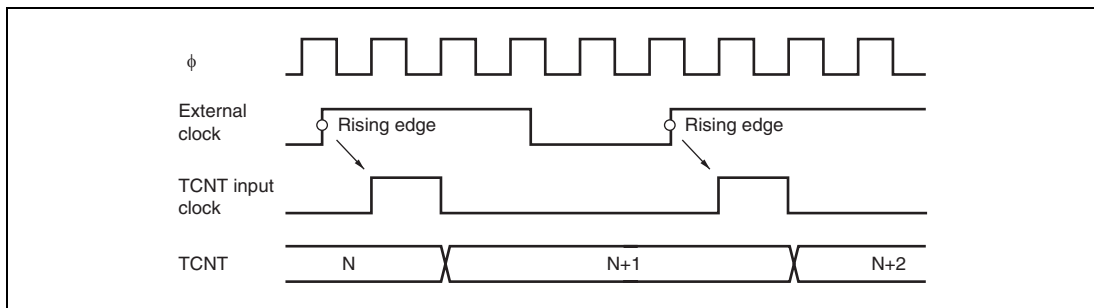

Figure 12.15 Count Timing for External Clock Source

12.5.2 Output Compare Output Timing

The compare match signal is generated in the last state in which TCNT and GR match (when TCNT changes from the matching value to the next value). When the compare match signal is generated, the output value selected in TIOR is output at the compare match output pin (FTIOA, FTIOB, FTIOC, or FTIOD).

When TCNT matches GR, the compare match signal is generated only after the next counter clock pulse is input.

Figure 12.16 shows the output compare timing.

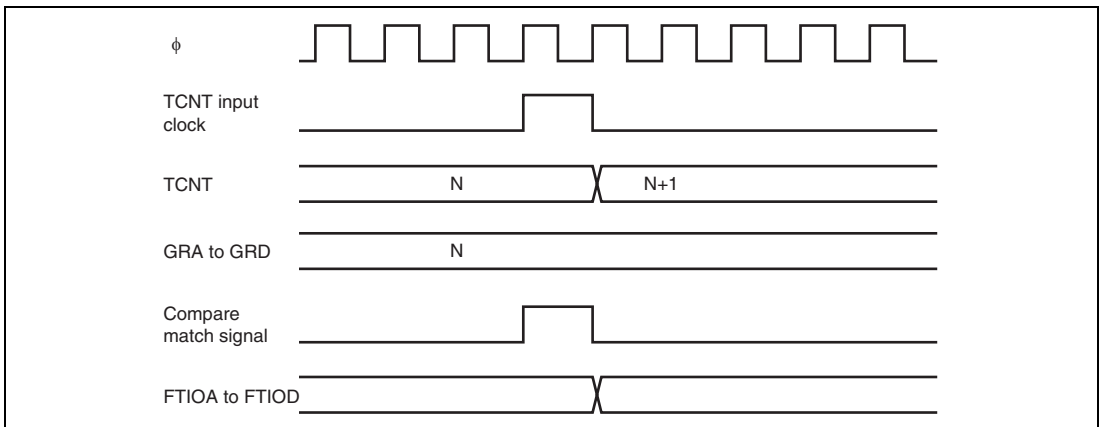

Figure 12.16 Output Compare Output Timing

12.5.3 Input Capture Timing

Input capture on the rising edge, falling edge, or both edges can be selected through settings in TIOR0 and TIOR1. Figure 12.17 shows the timing when the falling edge is selected. The pulse width of the input capture signal must be at least two system clock (ϕ) cycles; shorter pulses will not be detected correctly.

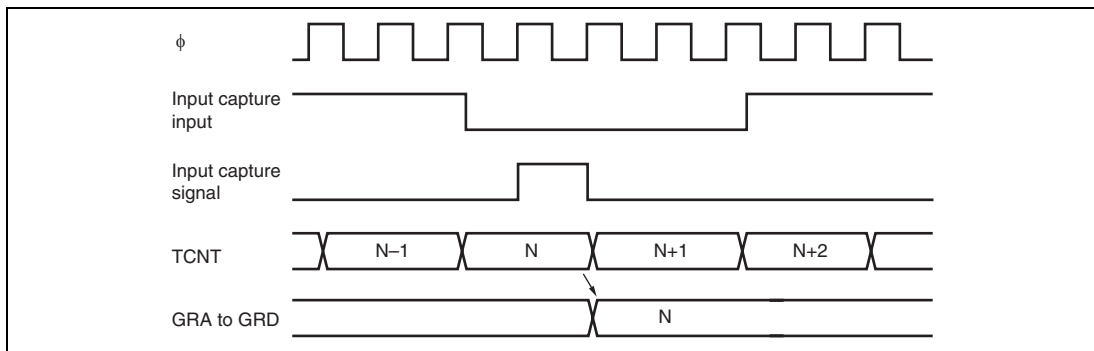

Figure 12.17 Input Capture Input Signal Timing

12.5.4 Timing of Counter Clearing by Compare Match

Figure 12.18 shows the timing when the counter is cleared by compare match A. When the GRA value is N, the counter counts from 0 to N, and its cycle is N + 1.

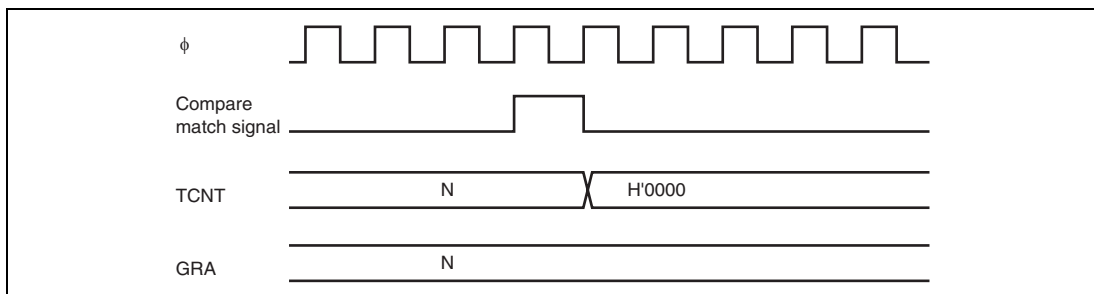

Figure 12.18 Timing of Counter Clearing by Compare Match

12.5.5 Buffer Operation Timing

Figures 12.19 and 12.20 show the buffer operation timing.

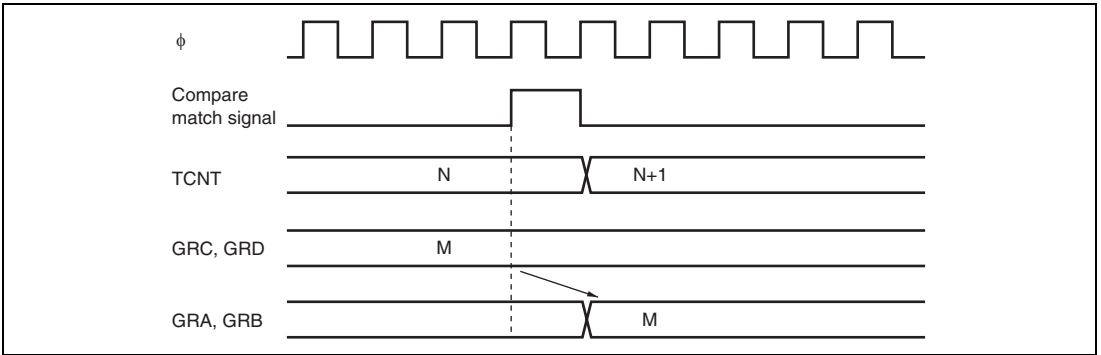

Figure 12.19 Buffer Operation Timing (Compare Match)

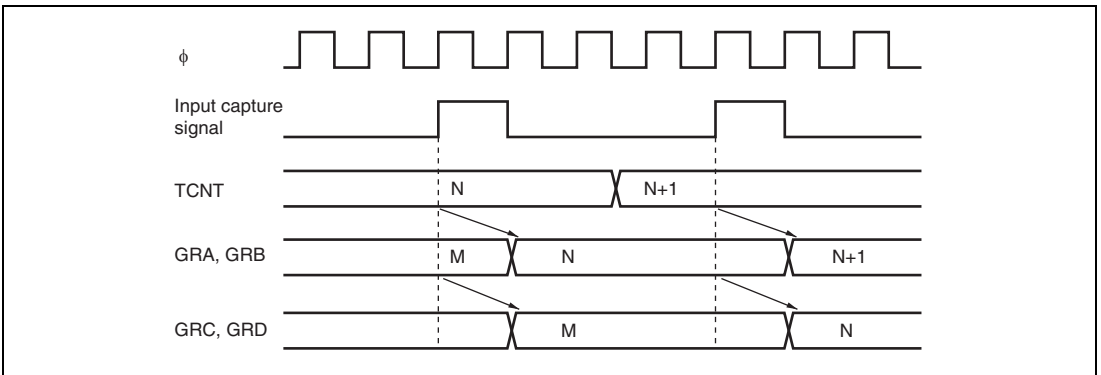

Figure 12.20 Buffer Operation Timing (Input Capture)

12.5.6 Timing of IMFA to IMFD Flag Setting at Compare Match

If a general register (GRA, GRB, GRC, or GRD) is used as an output compare register, the corresponding IMFA, IMFB, IMFC, or IMFD flag is set to 1 when TCNT matches the general register.

The compare match signal is generated in the last state in which the values match (when TCNT is updated from the matching count to the next count). Therefore, when TCNT matches a general register, the compare match signal is generated only after the next TCNT clock pulse is input.

Figure 12.21 shows the timing of the IMFA to IMFD flag setting at compare match.

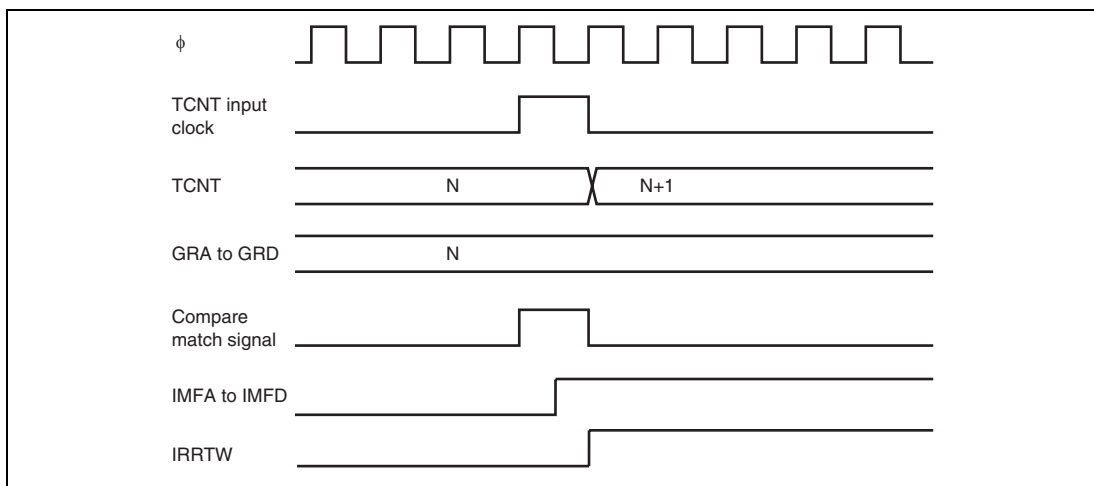

Figure 12.21 Timing of IMFA to IMFD Flag Setting at Compare Match

12.5.7 Timing of IMFA to IMFD Setting at Input Capture

If a general register (GRA, GRB, GRC, or GRD) is used as an input capture register, the corresponding IMFA, IMFB, IMFC, or IMFD flag is set to 1 when an input capture occurs. Figure 12.22 shows the timing of the IMFA to IMFD flag setting at input capture.

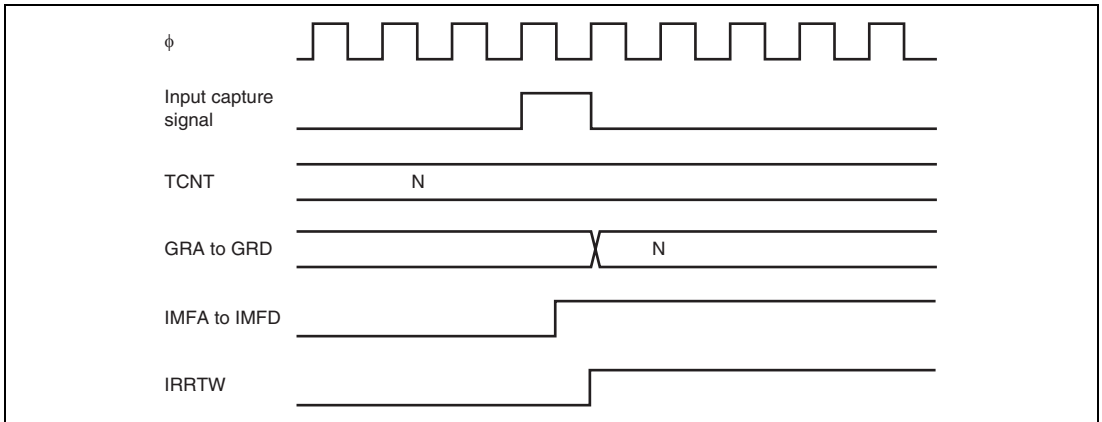

Figure 12.22 Timing of IMFA to IMFD Flag Setting at Input Capture

12.5.8 Timing of Status Flag Clearing

When the CPU reads a status flag while it is set to 1, then writes 0 in the status flag, the status flag is cleared. Figure 12.23 shows the status flag clearing timing.

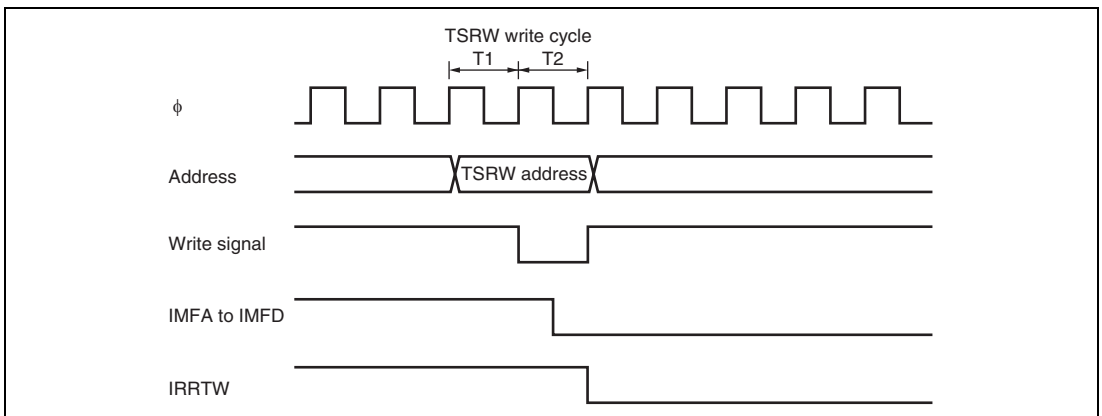

Figure 12.23 Timing of Status Flag Clearing by CPU

12.6 Usage Notes

The following types of contention or operation can occur in timer W operation.

1. The pulse width of the input clock signal and the input capture signal must be at least two system clock (ϕ) cycles; shorter pulses will not be detected correctly.
2. Writing to registers is performed in the T2 state of a TCNT write cycle.
If counter clear signal occurs in the T2 state of a TCNT write cycle, clearing of the counter takes priority and the write is not performed, as shown in figure 12.24. If counting-up is generated in the TCNT write cycle to contend with the TCNT counting-up, writing takes precedence.
3. Depending on the timing, TCNT may be incremented by a switch between different internal clock sources. When TCNT is internally clocked, an increment pulse is generated from the rising edge of an internal clock signal, that is divided system clock (ϕ). Therefore, as shown in figure 12.25 the switch is from a low clock signal to a high clock signal, the switchover is seen as a rising edge, causing TCNT to increment.
4. If timer W enters module standby mode while an interrupt request is generated, the interrupt request cannot be cleared. Before entering module standby mode, disable interrupt requests.
5. The TOA to TOD bits in TCRW decide the value of the FTIO pin, which is output until the first compare match occurs. Once a compare match occurs and this compare match changes the values of FTIOA to FTIOD output, the values of the FTIOA to FTIOD pin output and the values read from the TOA to TOD bits may differ. Moreover, when the writing to TCRW and the generation of the compare match A to D occur at the same timing, the writing to TCRW has the priority. Thus, output change due to the compare match is not reflected to the FTIOA to FTIOD pins. Therefore, when bit manipulation instruction is used to write to TCRW, the values of the FTIOA to FTIOD pin output may result in an unexpected result. When TCRW is to be written to while compare match is operating, stop the counter once before accessing to TCRW, read the port 8 state to reflect the values of FTIOA to FTIOD output, to TOA to TOD, and then restart the counter. Figure 12.26 shows an example when the compare match and the bit manipulation instruction to TCRW occur at the same timing.

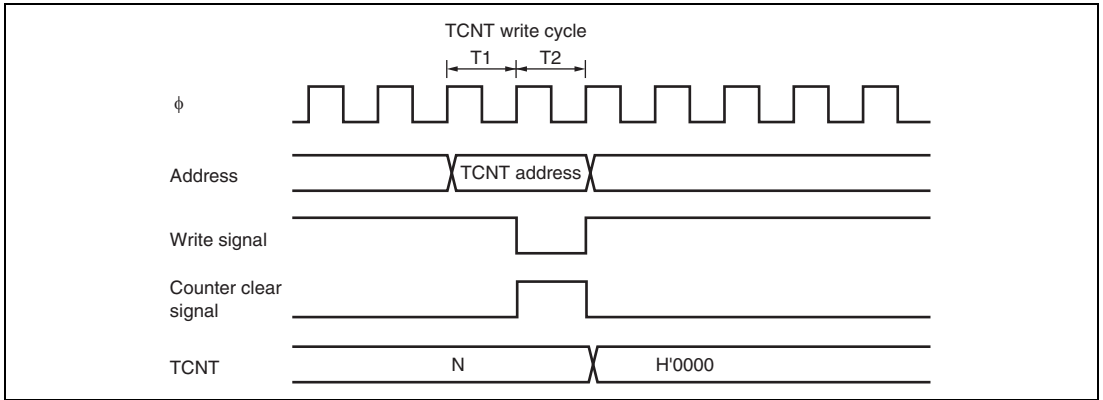

Figure 12.24 Contention between TCNT Write and Clear

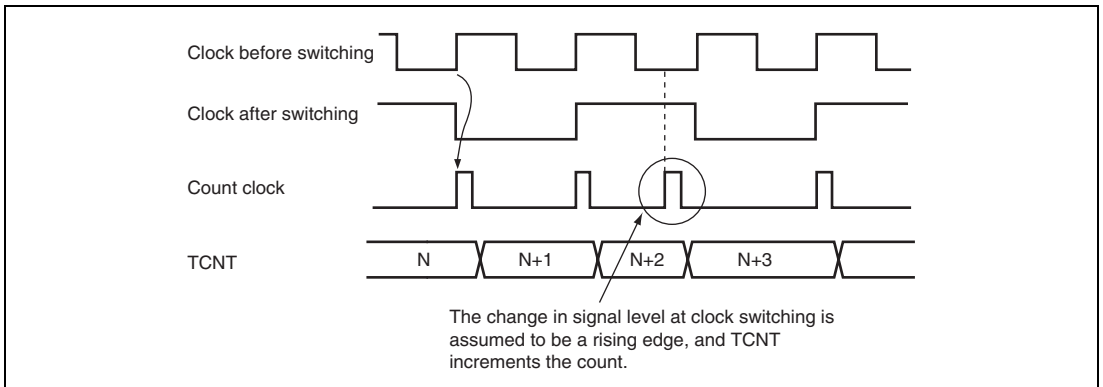

Figure 12.25 Internal Clock Switching and TCNT Operation

TCRW has been set to H'06. Compare match B and compare match C are used. The FTIOB pin is in the 1 output state, and is set to the toggle output or the 0 output by compare match B.

When BCLR#2, @TCRW is executed to clear the TOC bit (the FTIOC signal is low) and compare match B occurs at the same timing as shown below, the H'02 writing to TCRW has priority and compare match B does not drive the FTIOB signal low; the FTIOB signal remains high.

Bit	7	6	5	4	3	2	1	0
TCRW	CCLR	CKS2	CKS1	CKS0	TOD	TOC	TOB	TOA
Set value	0	0	0	0	0	1	1	0

BCLR#2, @TCRW

- (1) TCRW read operation: Read H'06
- (2) Modify operation: Modify H'06 to H'02
- (3) Write operation to TCRW: Write H'02

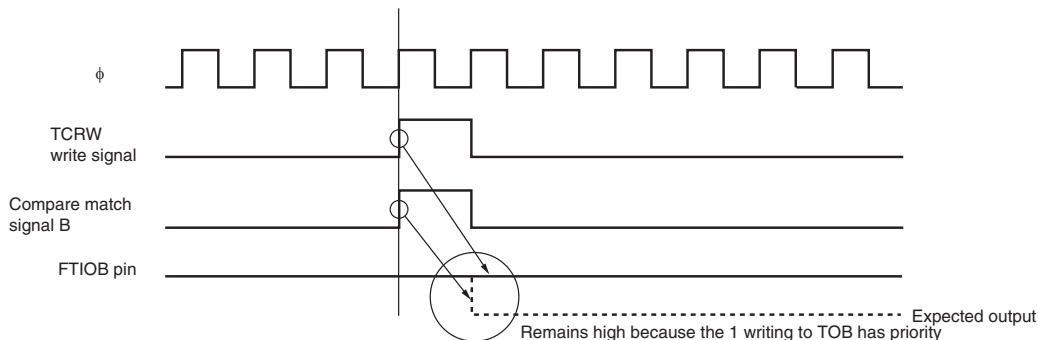

Figure 12.26 When Compare Match and Bit Manipulation Instruction to TCRW Occur at the Same Timing

Section 13 Watchdog Timer

The watchdog timer is an 8-bit timer that can generate an internal reset signal for this LSI if a system crash prevents the CPU from writing to the timer counter, thus allowing it to overflow.

The block diagram of the watchdog timer is shown in figure 13.1.

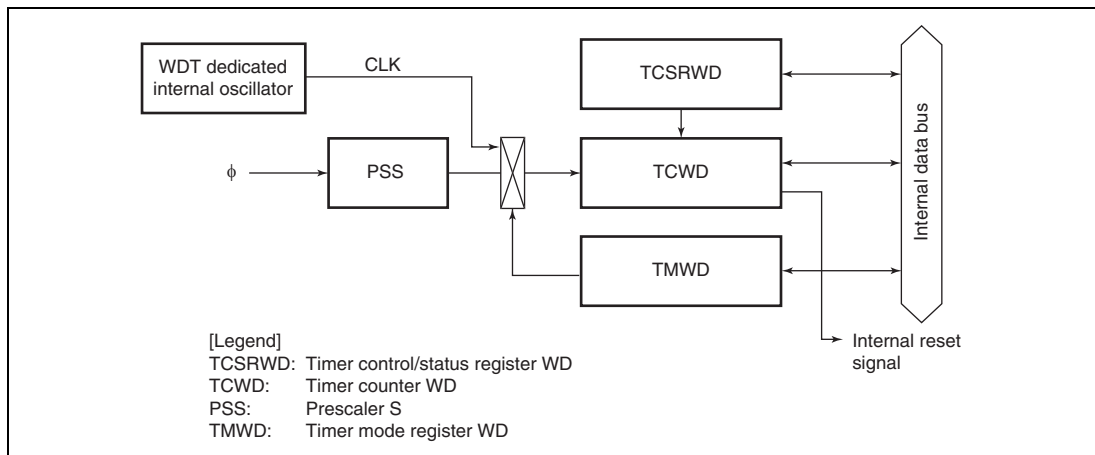

Figure 13.1 Block Diagram of Watchdog Timer

13.1 Features

- Selectable from nine counter input clocks.
 Eight clock sources ($\phi/64$, $\phi/128$, $\phi/256$, $\phi/512$, $\phi/1024$, $\phi/2048$, $\phi/4096$, and $\phi/8192$) or the WDT dedicated internal oscillator can be selected as the timer-counter clock. When the WDT dedicated internal oscillator is selected, it can operate as the watchdog timer in any operating mode.
- Reset signal generated on counter overflow
 An overflow period of 1 to 256 times the selected clock can be set.
- The watchdog timer is enabled in the initial state.
 It starts operating after the reset state is canceled.

13.2 Register Descriptions

The watchdog timer has the following registers.

- Timer control/status register WD (TCSRWD)
- Timer counter WD (TCWD)
- Timer mode register WD (TMWD)

13.2.1 Timer Control/Status Register WD (TCSRWD)

TCSRWD performs the TCSRWD and TCWD write control. TCSRWD also controls the watchdog timer operation and indicates the operating state. TCSRWD must be rewritten by using the MOV instruction. The bit manipulation instruction cannot be used to change the setting value.

Bit	Bit Name	Initial Value	R/W	Description
7	B6WI	1	R/W	Bit 6 Write Inhibit The TCWE bit can be written only when the write value of the B6WI bit is 0. This bit is always read as 1.
6	TCWE	0	R/W	Timer Counter WD Write Enable TCWD can be written when the TCWE bit is set to 1. When writing data to this bit, the value for bit 7 must be 0.
5	B4WI	1	R/W	Bit 4 Write Inhibit The TCSRWE bit can be written only when the write value of the B4WI bit is 0. This bit is always read as 1.
4	TCSRWE	0	R/W	Timer Control/Status Register WD Write Enable The WDON and WRST bits can be written when the TCSRWE bit is set to 1. When writing data to this bit, the value for bit 5 must be 0.
3	B2WI	1	R/W	Bit 2 Write Inhibit This bit can be written to the WDON bit only when the write value of the B2WI bit is 0. This bit is always read as 1.

Bit	Bit Name	Initial Value	R/W	Description
2	WDON	1	R/W	<p>Watchdog Timer On</p> <p>TCWD starts counting up when the WDON bit is set to 1 and halts when the WDON bit is cleared to 0. The watchdog timer is enabled in the initial state. When the watchdog timer is not used, clear the WDON bit to 0.</p> <p>[Setting conditions]</p> <ul style="list-style-type: none"> • Reset • When 1 is written to the WDON bit and 0 is written to the B2WI bit while the TCSRWE bit = 1 <p>[Clearing conditions]</p> <ul style="list-style-type: none"> • When 0 is written to the WDON bit and 0 is written to the B2WI bit while the TCSRWE bit = 1
1	BOWI	1	R/W	<p>Bit 0 Write Inhibit</p> <p>This bit can be written to the WRST bit only when the write value of the BOWI bit is 0. This bit is always read as 1.</p>
0	WRST*	0	R/W	<p>Watchdog Timer Reset</p> <p>[Setting condition]</p> <ul style="list-style-type: none"> • When TCWD overflows and an internal reset signal is generated <p>[Clearing conditions]</p> <ul style="list-style-type: none"> • Reset by the $\overline{\text{RES}}$ pin • When 0 is written to the WRST bit and 0 is written to the BOWI bit while the TCSRWE bit = 1

Note: * The WRST bit cannot be modified to 1.

13.2.2 Timer Counter WD (TCWD)

TCWD is an 8-bit readable/writable up-counter. When TCWD overflows from H'FF to H'00, the internal reset signal is generated and the WRST bit in TCSRWD is set to 1. TCWD is initialized to H'00.

13.2.3 Timer Mode Register WD (TMWD)

TMWD selects the input clock.

Bit	Bit Name	Initial Value	R/W	Description
7 to 4	—	All 1	—	Reserved These bits are always read as 1.
3	CKS3	1	R/W	Clock Select 3 to 0
2	CKS2	1	R/W	Select the clock to be input to TCWD.
1	CKS1	1	R/W	1000: Internal clock: counts on $\phi/64$
0	CKS0	1	R/W	1001: Internal clock: counts on $\phi/128$ 1010: Internal clock: counts on $\phi/256$ 1011: Internal clock: counts on $\phi/512$ 1100: Internal clock: counts on $\phi/1024$ 1101: Internal clock: counts on $\phi/2048$ 1110: Internal clock: counts on $\phi/4096$ 1111: Internal clock: counts on $\phi/8192$ 0XXX: WDT dedicated internal oscillator For the overflow periods of the WDT dedicated internal oscillator, see section 20, Electrical Characteristics.

[Legend]

X: Don't care

13.3 Operation

The watchdog timer is provided with an 8-bit counter. After the reset state is released, TCWD starts counting up. When the TCWD count value overflows H'FF, an internal reset signal is generated. The internal reset signal is output for a period of $256 \phi_{RC}$ clock cycles. As TCWD is a writable counter, it starts counting from the value set in TCWD. An overflow period in the range of 1 to 256 input clock cycles can therefore be set, according to the TCWD set value. When the watchdog timer is not used, stop TCWD counting by writing 0 to B2WI and WDON simultaneously while the TCSRWE bit in TCSRWD is set to 1. (To stop the watchdog timer, two write accesses to TCSRWD are required.)

Figure 13.2 shows an example of watchdog timer operation.

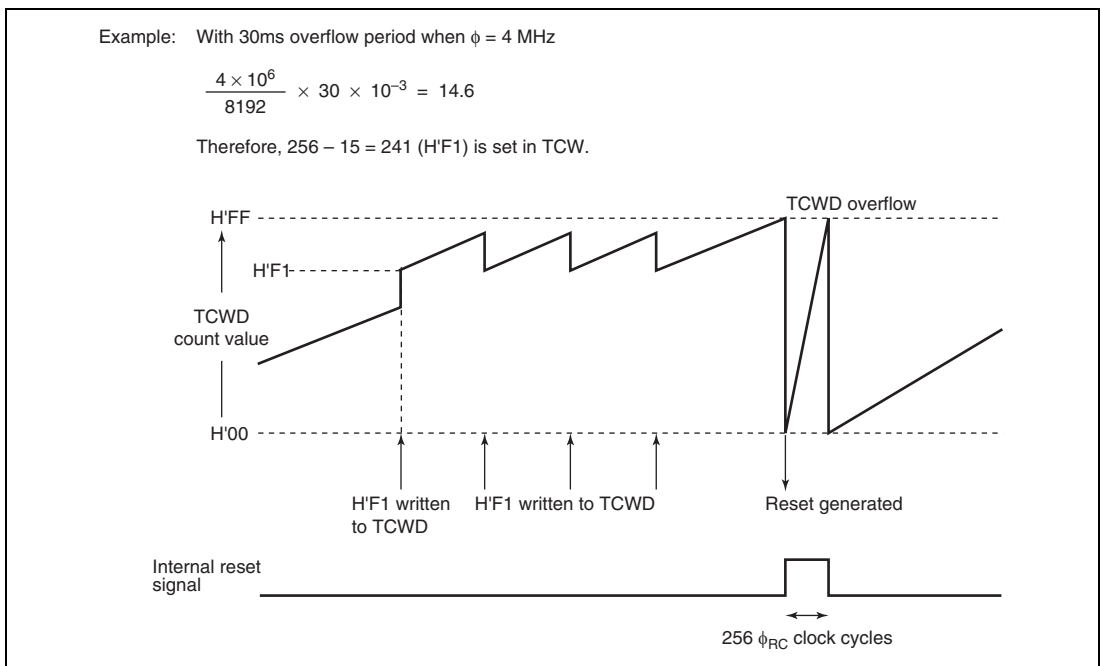

Figure 13.2 Watchdog Timer Operation Example

Section 14 Serial Communication Interface 3 (SCI3)

This LSI includes serial communication interface 3 (SCI3). SCI3 can handle both asynchronous and clocked synchronous serial communication. In asynchronous mode, serial data communication can be carried out using standard asynchronous communication chips such as a Universal Asynchronous Receiver/Transmitter (UART) or an Asynchronous Communication Interface Adapter (ACIA). A function is also provided for serial communication between processors (multiprocessor communication function).

Figure 14.1 is a block diagram of SCI3.

14.1 Features

- Choice of asynchronous or clocked synchronous serial communication mode
- Full-duplex communication capability
The transmitter and receiver are mutually independent, enabling transmission and reception to be executed simultaneously.
Double-buffering is used in both the transmitter and the receiver, enabling continuous transmission and continuous reception of serial data.
- On-chip baud rate generator allows any bit rate to be selected
- External clock or on-chip baud rate generator can be selected as a transfer clock source.
- Six interrupt sources
Transmit-end, transmit-data-empty, receive-data-full, overrun error, framing error, and parity error.
- Internal noise filter circuit (available for asynchronous serial communication only)

Asynchronous mode

- Data length: 7 or 8 bits
- Stop bit length: 1 or 2 bits
- Parity: Even, odd, or none
- Receive error detection: Parity, overrun, and framing errors
- Break detection: Break can be detected by reading the RXD pin level directly in the case of a framing error

Clocked synchronous mode

- Data length: 8 bits
- Receive error detection: Overrun errors

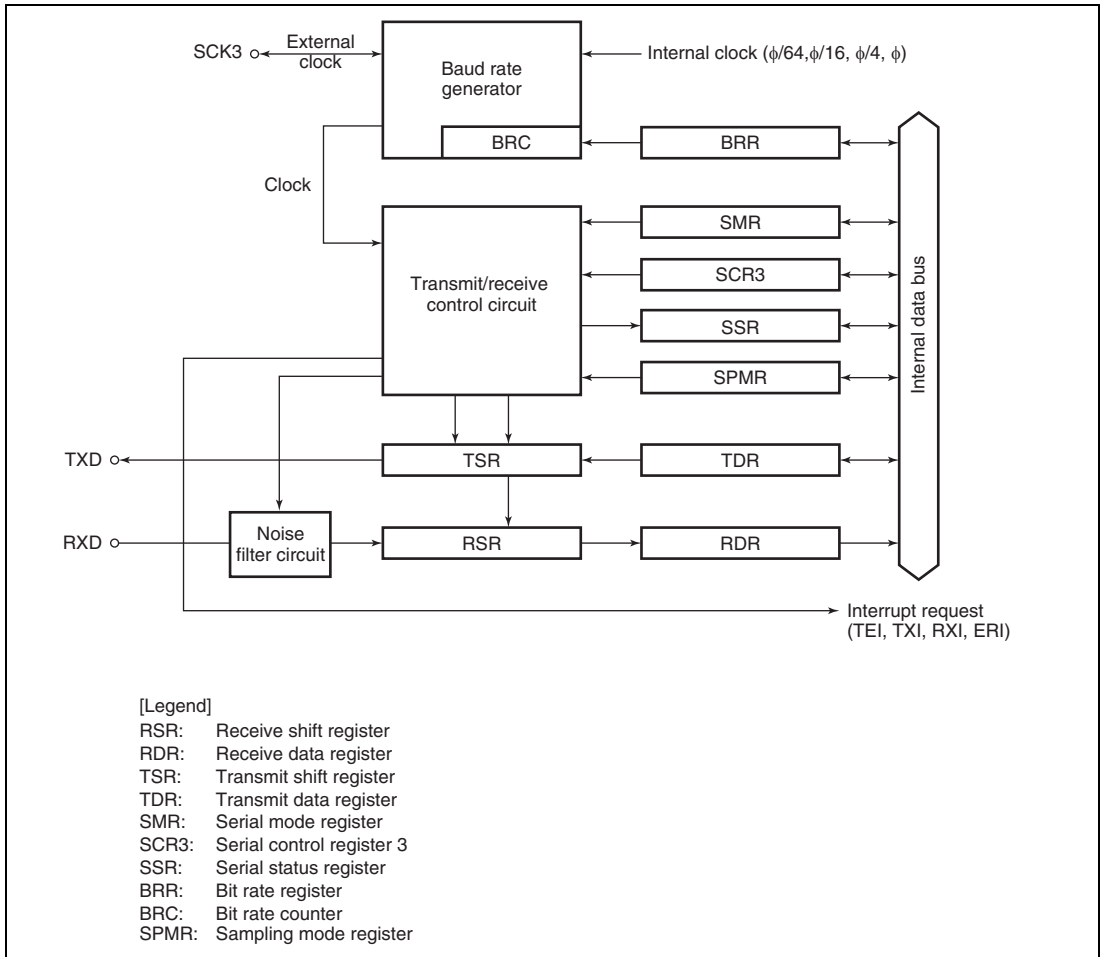

Figure 14.1 Block Diagram of SCI3

14.2 Input/Output Pins

Table 14.1 shows the SCI3 pin configuration.

Table 14.1 Pin Configuration

Pin Name	Abbreviation	I/O	Function
SCI3 clock	SCK3	Input/output	SCI3 clock input/output
SCI3 receive data input	RXD	Input	SCI3 receive data input
SCI3 transmit data output	TXD	Output	SCI3 transmit data output

14.3 Register Descriptions

SCI3 has the following registers for each channel.

- Receive shift register (RSR)
- Receive data register (RDR)
- Transmit shift register (TSR)
- Transmit data register (TDR)
- Serial mode register (SMR)
- Serial control register 3 (SCR3)
- Serial status register (SSR)
- Bit rate register (BRR)
- Sampling mode register (SPMR)

14.3.1 Receive Shift Register (RSR)

RSR is a shift register that is used to receive serial data input from the RXD pin and convert it into parallel data. When one frame of data has been received, it is transferred to RDR automatically. RSR cannot be directly accessed by the CPU.

14.3.2 Receive Data Register (RDR)

RDR is an 8-bit register that stores received data. When SCI3 has received one frame of serial data, it transfers the received serial data from RSR to RDR, where it is stored. After this, RSR is receive-enabled. As RSR and RDR function as a double buffer in this way, continuous receive operations are possible. After confirming that the RDRF bit in SSR is set to 1, read RDR only once. RDR cannot be written to by the CPU. RDR is initialized to H'00.

14.3.3 Transmit Shift Register (TSR)

TSR is a shift register that transmits serial data. To perform serial data transmission, SCI3 first transfers transmit data from TDR to TSR automatically, then sends the data that starts from the LSB to the TXD pin. TSR cannot be directly accessed by the CPU.

14.3.4 Transmit Data Register (TDR)

TDR is an 8-bit register that stores data for transmission. When SCI3 detects that TSR is empty, it transfers the transmit data written in TDR to TSR and starts transmission. The double-buffered structure of TDR and TSR enables continuous serial transmission. If the next transmit data has already been written to TDR during transmission of one-frame data, SCI3 transfers the written data to TSR to continue transmission. To achieve reliable serial transmission, write transmit data to TDR only once after confirming that the TDRE bit in SSR is set to 1. TDR is initialized to H'FF.

14.3.5 Serial Mode Register (SMR)

SMR is used to set the SCI3's serial transfer format and select the baud rate generator clock source.

Bit	Bit Name	Initial Value	R/W	Description
7	COM	0	R/W	Communication Mode 0: Asynchronous mode 1: Clocked synchronous mode
6	CHR	0	R/W	Character Length (enabled only in asynchronous mode) 0: Selects 8 bits as the data length. 1: Selects 7 bits as the data length.
5	PE	0	R/W	Parity Enable (enabled only in asynchronous mode) When this bit is set to 1, the parity bit is added to transmit data before transmission, and the parity bit is checked in reception.
4	PM	0	R/W	Parity Mode (enabled only when the PE bit is 1 in asynchronous mode) 0: Selects even parity. 1: Selects odd parity.
3	STOP	0	R/W	Stop Bit Length (enabled only in asynchronous mode) Selects the stop bit length in transmission. 0: 1 stop bit 1: 2 stop bits For reception, only the first stop bit is checked, regardless of the value in the bit. If the second stop bit is 0, it is treated as the start bit of the next transmit character.
2	MP	0	R/W	Multiprocessor Mode When this bit is set to 1, the multiprocessor communication function is enabled. The PE bit and PM bit settings are invalid in multiprocessor mode. In clocked synchronous mode, clear this bit to 0.

Bit	Bit Name	Initial Value	R/W	Description
1	CKS1	0	R/W	Clock Select 0 and 1
0	CKS0	0	R/W	These bits select the clock source for the baud rate generator. 00: ϕ clock (n = 0) 01: $\phi/4$ clock (n = 1) 10: $\phi/16$ clock (n = 2) 11: $\phi/64$ clock (n = 3) For the relationship between the bit rate register setting and the baud rate, see section 14.3.8, Bit Rate Register (BRR). n is the decimal representation of the value of n in BRR (see section 14.3.8, Bit Rate Register (BRR)).

14.3.6 Serial Control Register 3 (SCR3)

SCR3 is a register that enables or disables SCI3 transfer operations and interrupt requests, and is also used to select the transfer clock source. For details on interrupt requests, refer to section 14.7, Interrupts.

Bit	Bit Name	Initial Value	R/W	Description
7	TIE	0	R/W	Transmit Interrupt Enable When this bit is set to 1, the TXI interrupt request is enabled.
6	RIE	0	R/W	Receive Interrupt Enable When this bit is set to 1, RXI and ERI interrupt requests are enabled.
5	TE	0	R/W	Transmit Enable When this bit is set to 1, transmission is enabled.
4	RE	0	R/W	Receive Enable When this bit is set to 1, reception is enabled.

Bit	Bit Name	Initial Value	R/W	Description
3	MPIE	0	R/W	<p>Multiprocessor Interrupt Enable (enabled only when the MP bit in SMR is 1 in asynchronous mode)</p> <p>When this bit is set to 1, receive data in which the multiprocessor bit is 0 is skipped, and setting of the RDRF, FER, and OER status flags in SSR is disabled. On receiving data in which the multiprocessor bit is 1, this bit is automatically cleared and normal reception is resumed. For details, refer to section 14.6, Multiprocessor Communication Function.</p>
2	TEIE	0	R/W	<p>Transmit End Interrupt Enable</p> <p>When this bit is set to 1, TEI interrupt request is enabled.</p>
1	CKE1	0	R/W	Clock Enable 0 and 1
0	CKE0	0	R/W	<p>Selects the clock source.</p> <ul style="list-style-type: none"> • Asynchronous mode <ul style="list-style-type: none"> 00: On-chip baud rate generator 01: On-chip baud rate generator <ul style="list-style-type: none"> Outputs a clock of the same frequency as the bit rate from the SCK3 pin. 10: External clock <ul style="list-style-type: none"> Inputs a clock with a frequency 16 times the bit rate from the SCK3 pin. 11:Reserved • Clocked synchronous mode <ul style="list-style-type: none"> 00: On-chip clock (SCK3 pin functions as clock output) 01:Reserved 10: External clock (SCK3 pin functions as clock input) 11:Reserved

14.3.7 Serial Status Register (SSR)

SSR is a register containing status flags of SCI3 and multiprocessor bits for transfer. 1 cannot be written to flags TDRE, RDRF, OER, PER, and FER; they can only be cleared.

Bit	Bit Name	Initial Value	R/W	Description
7	TDRE	1	R/W	Transmit Data Register Empty Indicates whether TDR contains transmit data. [Setting conditions] <ul style="list-style-type: none"> • When the TE bit in SCR3 is 0 • When data is transferred from TDR to TSR [Clearing conditions] <ul style="list-style-type: none"> • When 0 is written to TDRE after reading TDRE = 1 • When the transmit data is written to TDR
6	RDRF	0	R/W	Receive Data Register Full Indicates that the received data is stored in RDR. [Setting condition] <ul style="list-style-type: none"> • When serial reception ends normally and receive data is transferred from RSR to RDR [Clearing conditions] <ul style="list-style-type: none"> • When 0 is written to RDRF after reading RDRF = 1 • When data is read from RDR
5	OER	0	R/W	Overrun Error [Setting condition] <ul style="list-style-type: none"> • When an overrun error occurs in reception [Clearing condition] <ul style="list-style-type: none"> • When 0 is written to OER after reading OER = 1
4	FER	0	R/W	Framing Error [Setting condition] <ul style="list-style-type: none"> • When a framing error occurs in reception [Clearing condition] <ul style="list-style-type: none"> • When 0 is written to FER after reading FER = 1

Bit	Bit Name	Initial Value	R/W	Description
3	PER	0	R/W	Parity Error [Setting condition] <ul style="list-style-type: none"> When a parity error is detected during reception [Clearing condition] <ul style="list-style-type: none"> When 0 is written to PER after reading PER = 1
2	TEND	1	R	Transmit End [Setting conditions] <ul style="list-style-type: none"> When the TE bit in SCR3 is 0 When TDRE = 1 at transmission of the last bit of a 1-frame serial transmit character [Clearing conditions] <ul style="list-style-type: none"> When 0 is written to TDRE after reading TDRE = 1 When the transmit data is written to TDR
1	MPBR	0	R	Multiprocessor Bit Receive MPBR stores the multiprocessor bit in the receive character data. When the RE bit in SCR3 is cleared to 0, its state is retained.
0	MPBT	0	R/W	Multiprocessor Bit Transfer MPBT stores the multiprocessor bit to be added to the transmit character data.

14.3.8 Bit Rate Register (BRR)

BRR is an 8-bit register that adjusts the bit rate. The initial value of BRR is H'FF. Table 14.2 shows the relationship between the N setting in BRR and the n setting in bits CKS1 and CKS0 of SMR in asynchronous mode. Table 14.3 shows the maximum bit rate for each frequency in asynchronous mode. The values shown in both tables 14.2 and 14.3 are values in active (high-speed) mode. Table 14.4 shows the relationship between the N setting in BRR and the n setting in bits CKS1 and CKS0 of SMR in clocked synchronous mode. The values shown in table 14.5 are values in active (high-speed) mode. The N setting in BRR and error for other operating frequencies and bit rates can be obtained by the following formulas:

[Asynchronous Mode]

$$N = \frac{\phi}{64 \times 2^{2n-1} \times B} \times 10^6 - 1$$

$$\text{Error (\%)} = \left\{ \frac{\phi \times 10^6}{(N + 1) \times B \times 64 \times 2^{2n-1}} - 1 \right\} \times 100$$

[Clocked Synchronous Mode]

$$N = \frac{\phi}{8 \times 2^{2n-1} \times B} \times 10^6 - 1$$

Legend B: Bit rate (bit/s)

N: BRR setting for baud rate generator ($0 \leq N \leq 255$)

ϕ : Operating frequency (MHz)

n: CSK1 and CSK0 settings in SMR ($0 \leq n \leq 3$)

Table 14.2 Examples of BRR Settings for Various Bit Rates (Asynchronous Mode)

Bit Rate (bits/s)	Operating Frequency ϕ (MHz)											
	2			2.097152			2.4576			3		
	n	N	Error (%)	n	N	Error (%)	n	N	Error (%)	n	N	Error (%)
110	1	141	0.03	1	148	-0.04	1	174	-0.26	1	212	0.03
150	1	103	0.16	1	108	0.21	1	127	0.00	1	155	0.16
300	0	207	0.16	0	217	0.21	0	255	0.00	1	77	0.16
600	0	103	0.16	0	108	0.21	0	127	0.00	0	155	0.16
1200	0	51	0.16	0	54	-0.70	0	63	0.00	0	77	0.16
2400	0	25	0.16	0	26	1.14	0	31	0.00	0	38	0.16
4800	0	12	0.16	0	13	-2.48	0	15	0.00	0	19	-2.34
9600	0	6	-6.99	0	6	-2.48	0	7	0.00	0	9	-2.34
19200	0	2	8.51	0	2	13.78	0	3	0.00	0	4	-2.34
31250	0	1	0.00	0	1	4.86	0	1	22.88	0	2	0.00
38400	0	1	-18.62	0	1	-14.67	0	1	0.00	—	—	—

Bit Rate (bits/s)	Operating Frequency ϕ (MHz)											
	3.6864			4			4.9152			5		
	n	N	Error (%)	n	N	Error (%)	n	N	Error (%)	n	N	Error (%)
110	2	64	0.70	2	70	0.03	2	86	0.31	2	88	-0.25
150	1	191	0.00	1	207	0.16	1	255	0.00	2	64	0.16
300	1	95	0.00	1	103	0.16	1	127	0.00	1	129	0.16
600	0	191	0.00	0	207	0.16	0	255	0.00	1	64	0.16
1200	0	95	0.00	0	103	0.16	0	127	0.00	0	129	0.16
2400	0	47	0.00	0	51	0.16	0	63	0.00	0	64	0.16
4800	0	23	0.00	0	25	0.16	0	31	0.00	0	32	-1.36
9600	0	11	0.00	0	12	0.16	0	15	0.00	0	15	1.73
19200	0	5	0.00	0	6	-6.99	0	7	0.00	0	7	1.73
31250	—	—	—	0	3	0.00	0	4	-1.70	0	4	0.00
38400	0	2	0.00	0	2	8.51	0	3	0.00	0	3	1.73

[Legend]

—: A setting is available but error occurs

Bit Rate (bit/s)	Operating Frequency ϕ (MHz)								
	6			6.144			7.3728		
	n	N	Error (%)	n	N	Error (%)	n	N	Error (%)
110	2	106	-0.44	2	108	0.08	2	130	-0.07
150	2	77	0.16	2	79	0.00	2	95	0.00
300	1	155	0.16	1	159	0.00	1	191	0.00
600	1	77	0.16	1	79	0.00	1	95	0.00
1200	0	155	0.16	0	159	0.00	0	191	0.00
2400	0	77	0.16	0	79	0.00	0	95	0.00
4800	0	38	0.16	0	39	0.00	0	47	0.00
9600	0	19	-2.34	0	19	0.00	0	23	0.00
19200	0	9	-2.34	0	9	0.00	0	11	0.00
31250	0	5	0.00	0	5	2.40	0	6	5.33
38400	0	4	-2.34	0	4	0.00	0	5	0.00

Bit Rate (bit/s)	Operating Frequency ϕ (MHz)								
	8			9.8304			10		
	n	N	Error (%)	n	N	Error (%)	n	N	Error (%)
110	2	141	0.03	2	174	-0.26	2	177	-0.25
150	2	103	0.16	2	127	0.00	2	129	0.16
300	1	207	0.16	1	255	0.00	2	64	0.16
600	1	103	0.16	1	127	0.00	1	129	0.16
1200	0	207	0.16	0	255	0.00	1	64	0.16
2400	0	103	0.16	0	127	0.00	0	129	0.16
4800	0	51	0.16	0	63	0.00	0	64	0.16
9600	0	25	0.16	0	31	0.00	0	32	-1.36
19200	0	12	0.16	0	15	0.00	0	15	1.73
31250	0	7	0.00	0	9	-1.70	0	9	0.00
38400	0	6	-6.99	0	7	0.00	0	7	1.73

Table 14.3 Maximum Bit Rate for Each Frequency (Asynchronous Mode)

ϕ (MHz)	Maximum Bit Rate (bit/s)	n	N	ϕ (MHz)	Maximum Bit Rate (bit/s)	n	N
2	62500	0	0	5	156250	0	0
2.097152	65536	0	0	6	187500	0	0
2.4576	76800	0	0	6.144	192000	0	0
3	93750	0	0	7.3728	230400	0	0
3.6864	115200	0	0	8	250000	0	0
4	125000	0	0	9.8304	307200	0	0
4.9152	153600	0	0	10	312500	0	0

Table 14.4 Examples of BRR Settings for Various Bit Rates (Clocked Synchronous Mode)

Bit Rate (bit/s)	Operating Frequency ϕ (MHz)							
	2		4		8		10	
	n	N	n	N	n	N	n	N
110	3	70	—	—	—	—	—	—
250	2	124	2	249	3	124	—	—
500	1	249	2	124	2	249	—	—
1k	1	124	1	249	2	124	—	—
2.5k	0	199	1	99	1	199	1	249
5k	0	99	0	199	1	99	1	124
10k	0	49	0	99	0	199	0	249
25k	0	19	0	39	0	79	0	99
50k	0	9	0	19	0	39	0	49
100k	0	4	0	9	0	19	0	24
250k	0	1	0	3	0	7	0	9
500k	0	0*	0	1	0	3	0	4
1M			0	0*	0	1	—	—
2M					0	0*	—	—
2.5M							0	0*
4M								

[Legend]

Blank: No setting is available.

—: A setting is available but error occurs.

*: Continuous transfer is not possible.

14.3.9 Sampling Mode Register (SPMR)

SPMR controls the serial communication function.

Bit	Bit Name	Initial Value	R/W	Description
7 to 3	—	All 1	—	Reserved These bits are always read as 1.
2	STDSPM	1	R/W	Noise Filter Function Select Selects the noise filter function for the RXD pin in asynchronous mode. 0: Noise filter circuit is enabled 1: Noise filter circuit is disabled
1, 0	—	All 1	—	Reserved These bits are always read as 1.

- Noise Filter Circuit

The RXD input signal is latched through the noise filter circuit. The noise filter circuit comprises a series of three latch circuits and a match detection circuit. The RXD input signal is sampled by the basic clock with the 16 times the transfer clock frequency. If three latch outputs match, its level is transferred to the next stage. If not, the circuit holds the previous value.

That is, when the incoming signal holds the same level for three clock cycles, it is regarded as the proper signal. If the levels of the signal is less than three clock cycles, the signal is regarded as a noise.

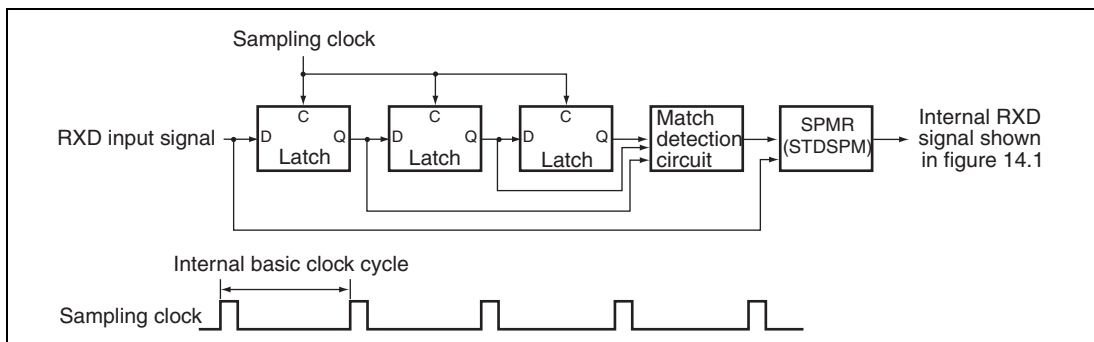

Figure 14.2 Block Diagram of Noise Filter Circuit

14.4 Operation in Asynchronous Mode

Figure 14.3 shows the general format for asynchronous serial communication. One character (or frame) consists of a start bit (low level), followed by data (in LSB-first order), a parity bit (high or low level), and finally stop bits (high level). Inside the SCI3, the transmitter and receiver are independent units, enabling full-duplex. Both the transmitter and the receiver also have a double-buffered structure, so data can be read or written during transmission or reception, enabling continuous data transfer.

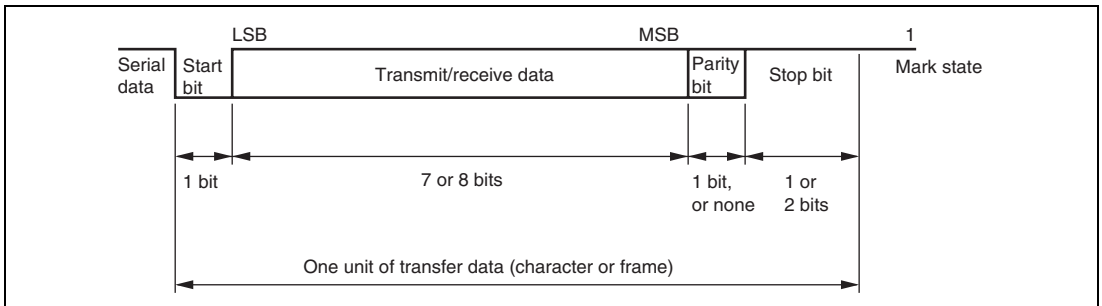

Figure 14.3 Data Format in Asynchronous Communication

14.4.1 Clock

Either an internal clock generated by the on-chip baud rate generator or an external clock input at the SCK3 pin can be selected as the SCI3's serial clock, according to the setting of the COM bit in SMR and the CKE0 and CKE1 bits in SCR3. When an external clock is input at the SCK3 pin, the clock frequency should be 16 times the bit rate used.

When SCI3 is operated on an internal clock, the clock can be output from the SCK3 pin. The frequency of the clock output in this case is equal to the bit rate, and the phase is such that the rising edge of the clock is in the middle of the transmit data, as shown in figure 14.4.

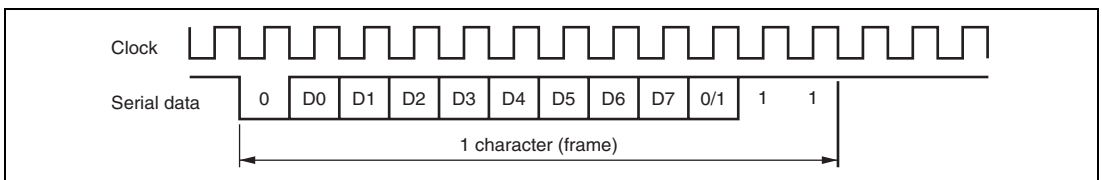

Figure 14.4 Relationship between Output Clock and Transfer Data Phase (Asynchronous Mode) (Example with 8-Bit Data, Parity, Two Stop Bits)

14.4.2 SCI3 Initialization

Before transmitting and receiving data, you should first clear the TE and RE bits in SCR3 to 0, then initialize SCI3 as described below. When the operating mode, or transfer format, is changed for example, the TE and RE bits must be cleared to 0 before making the change using the following procedure. When the TE bit is cleared to 0, the TDRE flag is set to 1. Note that clearing the RE bit to 0 does not initialize the contents of the RDRF, PER, FER, and OER flags, or the contents of RDR. When the external clock is used in asynchronous mode, the clock must be supplied even during initialization.

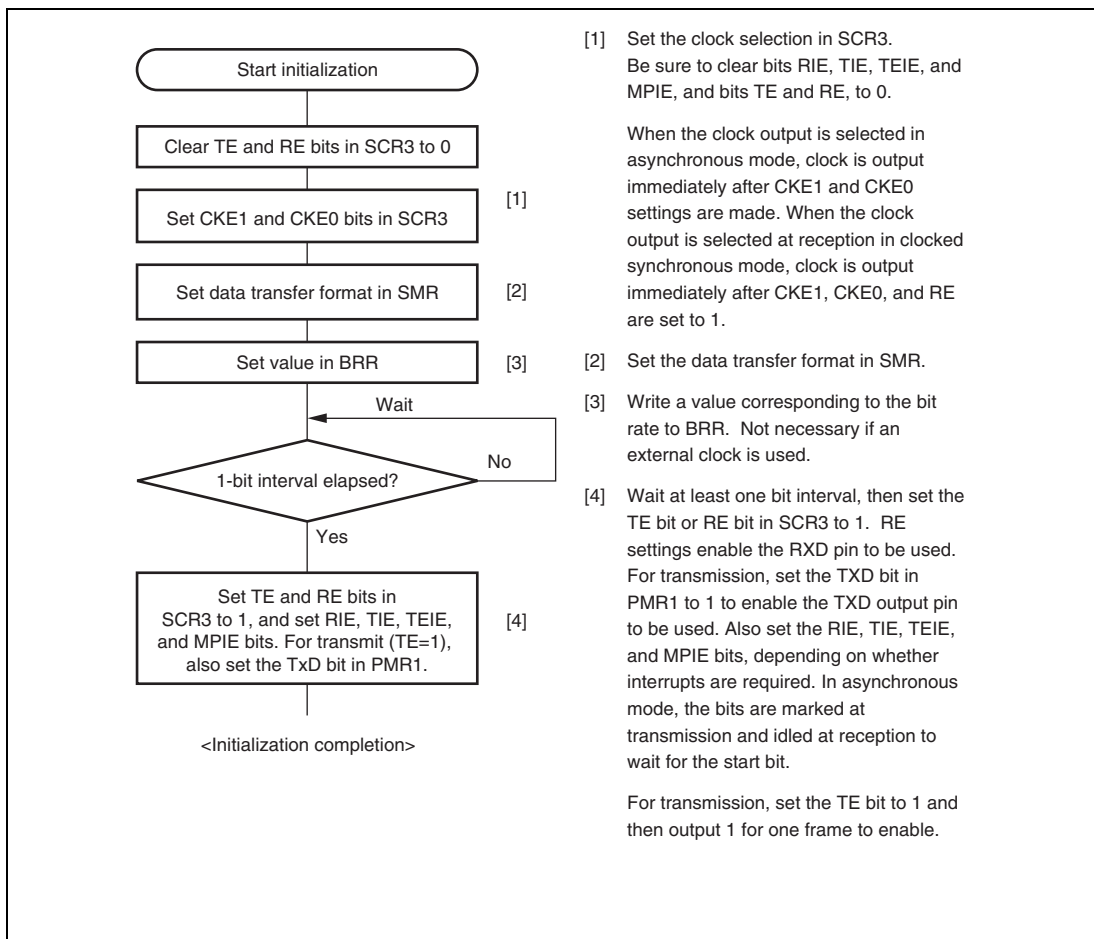

Figure 14.5 Sample SCI3 Initialization Flowchart

14.4.3 Data Transmission

Figure 14.6 shows an example of operation for transmission in asynchronous mode. In transmission, SCI3 operates as described below.

1. SCI3 monitors the TDRE flag in SSR. If the flag is cleared to 0, SCI3 recognizes that data has been written to TDR, and transfers the data from TDR to TSR.
2. After transferring data from TDR to TSR, SCI3 sets the TDRE flag to 1 and starts transmission. If the TIE bit is set to 1 at this time, a TXI interrupt request is generated. Continuous transmission is possible because the TXI interrupt routine writes next transmit data to TDR before transmission of the current transmit data has been completed.
3. SCI3 checks the TDRE flag at the timing for sending the stop bit.
4. If the TDRE flag is 0, the data is transferred from TDR to TSR, the stop bit is sent, and then serial transmission of the next frame is started.
5. If the TDRE flag is 1, the TEND flag in SSR is set to 1, the stop bit is sent, and then the “mark state” is entered, in which 1 is output. If the TEIE bit in SCR3 is set to 1 at this time, a TEI interrupt request is generated.
6. Figure 14.7 shows a sample flowchart for transmission in asynchronous mode.

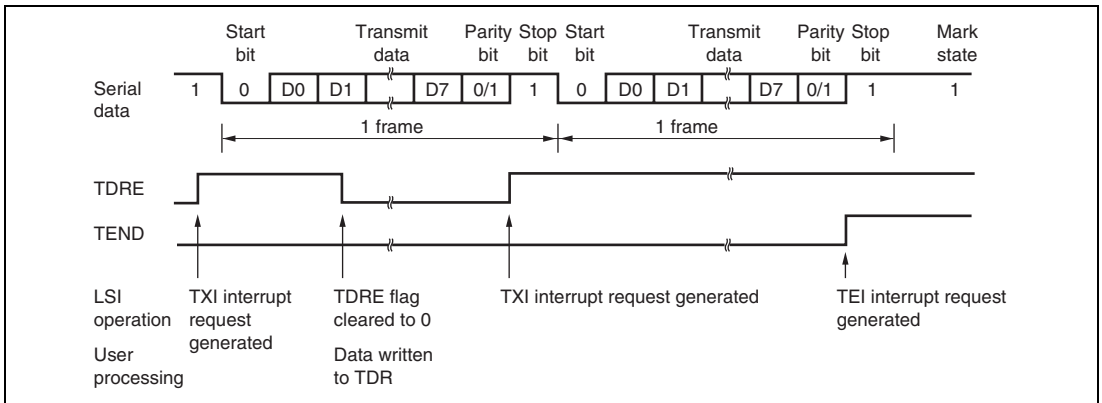

Figure 14.6 Example of SCI3 Transmission in Asynchronous Mode (8-Bit Data, Parity, One Stop Bit)

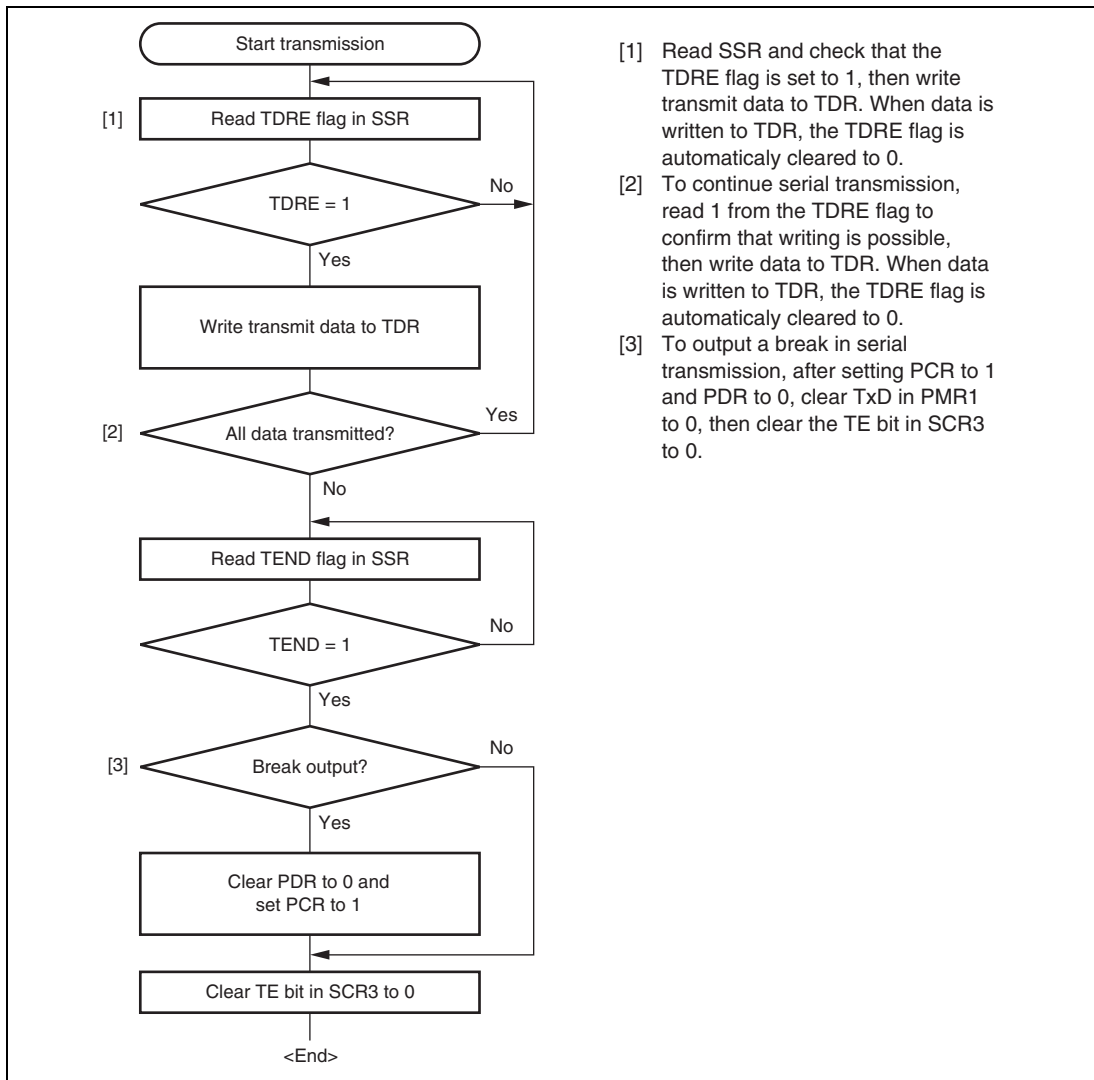

Figure 14.7 Sample Serial Transmission Data Flowchart (Asynchronous Mode)

14.4.4 Serial Data Reception

Figure 14.8 shows an example of operation for reception in asynchronous mode. In serial reception, SCI3 operates as described below.

1. SCI3 monitors the communication line. If a start bit is detected, SCI3 performs internal synchronization, receives receive data in RSR, and checks the parity bit and stop bit.
2. If an overrun error occurs (when reception of the next data is completed while the RDRF flag is still set to 1), the OER bit in SSR is set to 1. If the RIE bit in SCR3 is set to 1 at this time, an ERI interrupt request is generated. Receive data is not transferred to RDR.
3. If a parity error is detected, the PER bit in SSR is set to 1 and receive data is transferred to RDR. If the RIE bit in SCR3 is set to 1 at this time, an ERI interrupt request is generated.
4. If a framing error is detected (when the stop bit is 0), the FER bit in SSR is set to 1 and receive data is transferred to RDR. If the RIE bit in SCR3 is set to 1 at this time, an ERI interrupt request is generated.
5. If reception is completed successfully, the RDRF bit in SSR is set to 1, and receive data is transferred to RDR. If the RIE bit in SCR3 is set to 1 at this time, an RXI interrupt request is generated. Continuous reception is possible because the RXI interrupt routine reads the receive data transferred to RDR before reception of the next receive data has been completed.

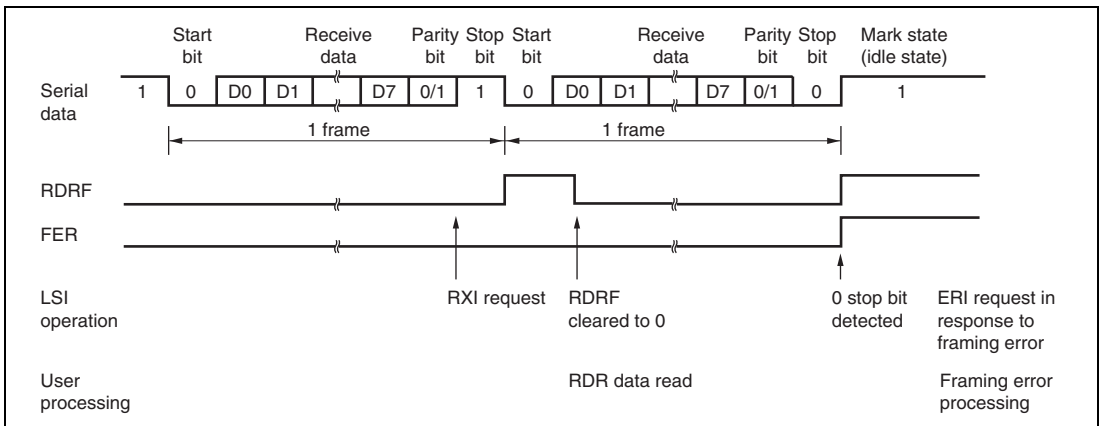

Figure 14.8 Example of SCI3 Reception in Asynchronous Mode (8-Bit Data, Parity, One Stop Bit)

Table 14.5 shows the states of the SSR status flags and receive data handling when a receive error is detected. If a receive error is detected, the RDRF flag retains its state before receiving data. Reception cannot be resumed while a receive error flag is set to 1. Accordingly, clear the OER, FER, PER, and RDRF bits to 0 before resuming reception. Figure 14.9 shows a sample flow chart for serial data reception.

Table 14.5 SSR Status Flags and Receive Data Handling

SSR Status Flag				Receive Data	Receive Error Type
RDRF*	OER	FER	PER		
1	1	0	0	Lost	Overflow error
0	0	1	0	Transferred to RDR	Framing error
0	0	0	1	Transferred to RDR	Parity error
1	1	1	0	Lost	Overflow error + framing error
1	1	0	1	Lost	Overflow error + parity error
0	0	1	1	Transferred to RDR	Framing error + parity error
1	1	1	1	Lost	Overflow error + framing error + parity error

Note: * The RDRF flag retains the state it had before data reception.

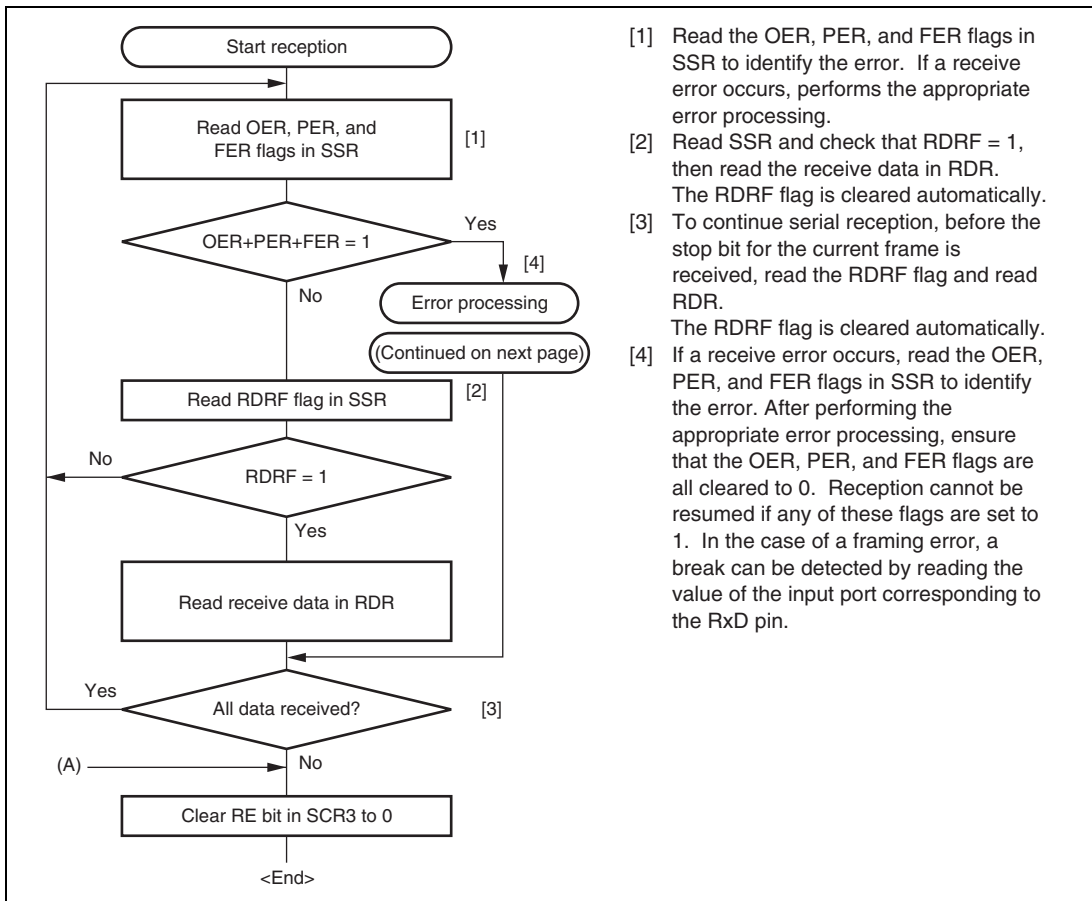

- [1] Read the OER, PER, and FER flags in SSR to identify the error. If a receive error occurs, performs the appropriate error processing.
- [2] Read SSR and check that RDRF = 1, then read the receive data in RDR. The RDRF flag is cleared automatically.
- [3] To continue serial reception, before the stop bit for the current frame is received, read the RDRF flag and read RDR. The RDRF flag is cleared automatically.
- [4] If a receive error occurs, read the OER, PER, and FER flags in SSR to identify the error. After performing the appropriate error processing, ensure that the OER, PER, and FER flags are all cleared to 0. Reception cannot be resumed if any of these flags are set to 1. In the case of a framing error, a break can be detected by reading the value of the input port corresponding to the RxD pin.

Figure 14.9 Sample Serial Reception Data Flowchart (Asynchronous Mode)

14.5 Operation in Clocked Synchronous Mode

Figure 14.10 shows the general format for clocked synchronous communication. In clocked synchronous mode, data is transmitted or received synchronous with clock pulses. A single character in the transmit data consists of the 8-bit data starting from the LSB. In clocked synchronous serial communication, data on the transmission line is output from one falling edge of the synchronization clock to the next. In clocked synchronous mode, SCI3 receives data in synchronous with the rising edge of the synchronization clock. After 8-bit data is output, the transmission line holds the MSB state. In clocked synchronous mode, no parity or multiprocessor bit is added. Inside the SCI3, the transmitter and receiver are independent units, enabling full-duplex communication through the use of a common clock. Both the transmitter and the receiver also have a double-buffered structure, so data can be read or written during transmission or reception, enabling continuous data transfer.

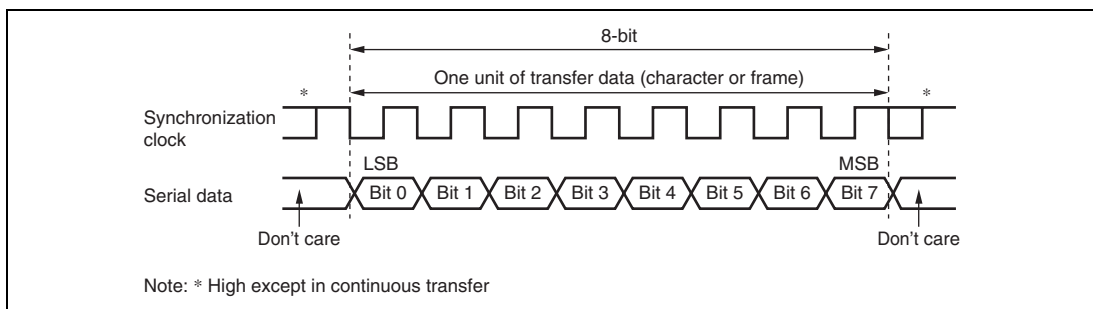

Figure 14.10 Data Format in Clocked Synchronous Communication

14.5.1 Clock

Either an internal clock generated by the on-chip baud rate generator or an external synchronization clock input at the SCK3 pin can be selected, according to the setting of the COM bit in SMR and CKE0 and CKE1 bits in SCR3. When SCI3 is operated on an internal clock, the synchronization clock is output from the SCK3 pin. Eight synchronization clock pulses are output in the transfer of one character, and when no transfer is performed the clock is fixed high.

14.5.2 SCI3 Initialization

Before transmitting and receiving data, SCI3 should be initialized as described in a sample flowchart in figure 14.5.

14.5.3 Serial Data Transmission

Figure 14.11 shows an example of SCI3 operation for transmission in clocked synchronous mode. In serial transmission, SCI3 operates as described below.

1. SCI3 monitors the TDRE flag in SSR, and if the flag is 0, SCI3 recognizes that data has been written to TDR, and transfers the data from TDR to TSR.
2. SCI3 sets the TDRE flag to 1 and starts transmission. If the TIE bit in SCR3 is set to 1 at this time, a transmit data empty interrupt (TXI) is generated.
3. 8-bit data is sent from the TXD pin synchronized with the output clock when output clock mode has been specified, and synchronized with the input clock when use of an external clock has been specified. Serial data is transmitted sequentially from the LSB (bit 0), from the TXD pin.
4. SCI3 checks the TDRE flag at the timing for sending the MSB (bit 7).
5. If the TDRE flag is cleared to 0, data is transferred from TDR to TSR, and serial transmission of the next frame is started.
6. If the TDRE flag is set to 1, the TEND flag in SSR is set to 1, and the TDRE flag maintains the output state of the last bit. If the TEIE bit in SCR3 is set to 1 at this time, a TEI interrupt request is generated.
7. The SCK3 pin is fixed high at the end of transmission.

Figure 14.12 shows a sample flow chart for serial data transmission. Even if the TDRE flag is cleared to 0, transmission will not start while a receive error flag (OER, FER, or PER) is set to 1. Make sure that the receive error flags are cleared to 0 before starting transmission.

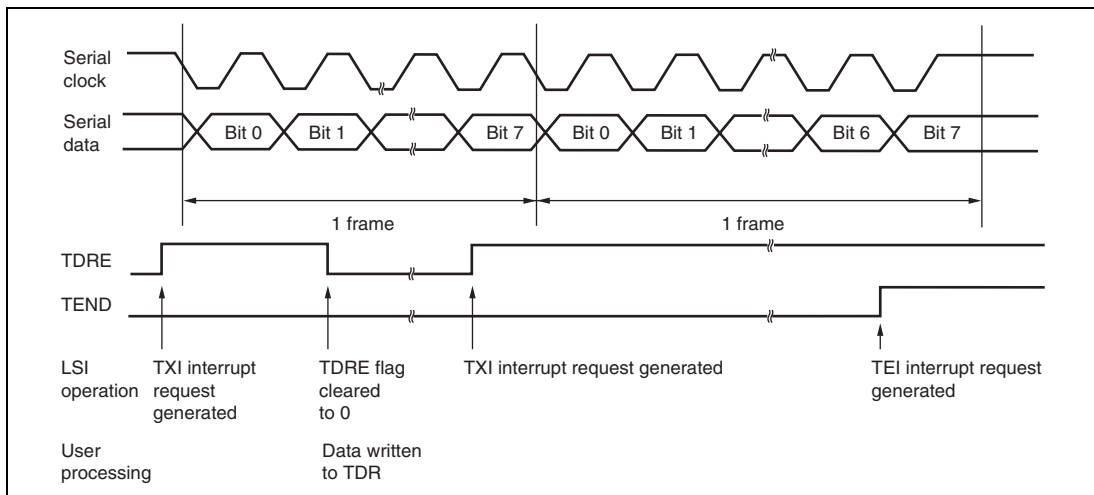

Figure 14.11 Example of SCI3 Transmission in Clocked Synchronous Mode

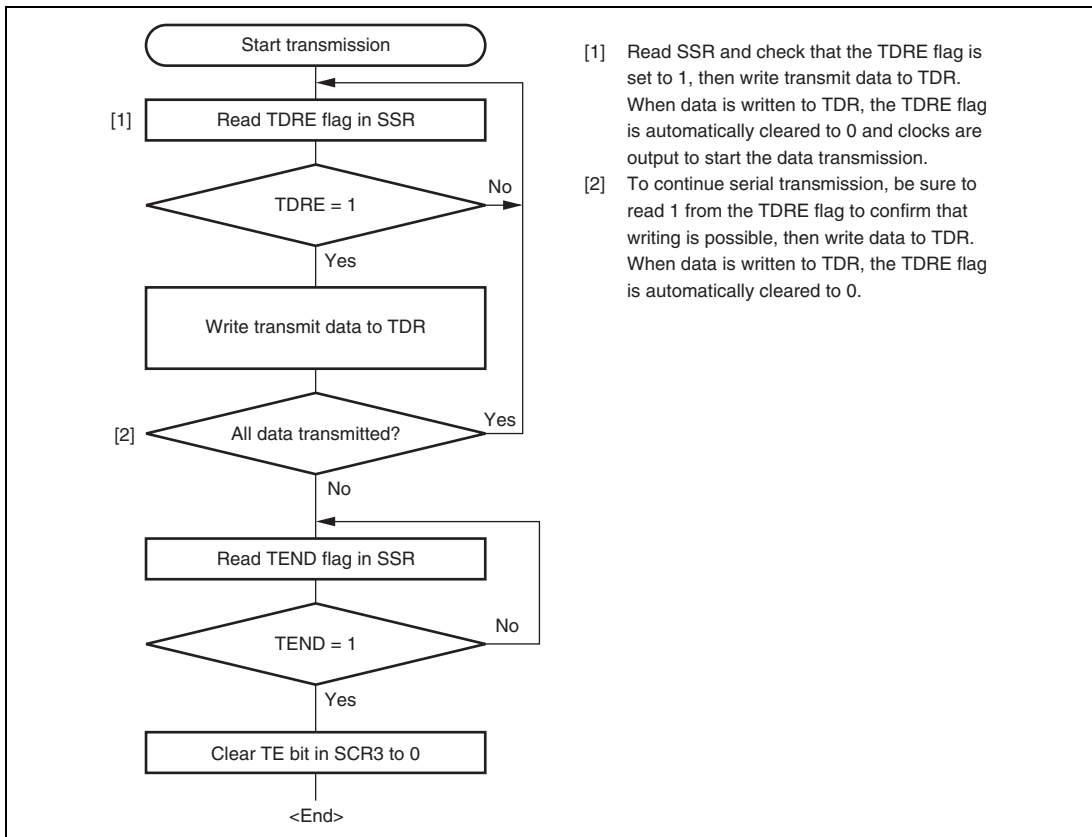

Figure 14.12 Sample Serial Transmission Flowchart (Clocked Synchronous Mode)

14.5.4 Serial Data Reception (Clocked Synchronous Mode)

Figure 14.13 shows an example of SCI3 operation for reception in clocked synchronous mode. In serial reception, SCI3 operates as described below.

1. SCI3 performs internal initialization synchronous with a synchronization clock input or output, starts receiving data.
2. SCI3 stores the receive data in RSR.
3. If an overrun error occurs (when reception of the next data is completed while the RDRF flag in SSR is still set to 1), the OER bit in SSR is set to 1. If the RIE bit in SCR3 is set to 1 at this time, an ERI interrupt request is generated, receive data is not transferred to RDR, and the RDRF flag remains to be set to 1.
4. If reception is completed successfully, the RDRF bit in SSR is set to 1, and receive data is transferred to RDR. If the RIE bit in SCR3 is set to 1 at this time, an RXI interrupt request is generated.

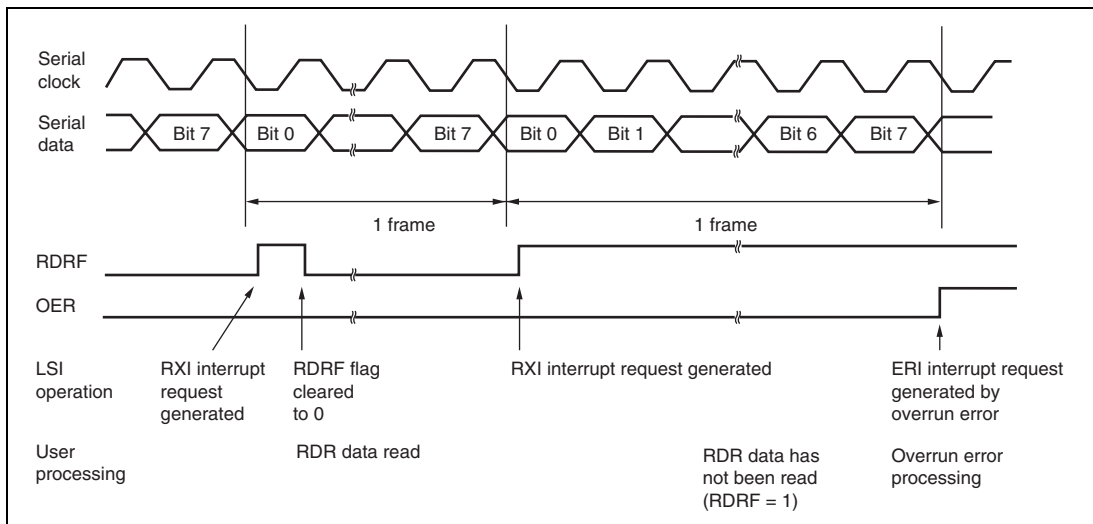

Figure 14.13 Example of SCI3 Reception in Clocked Synchronous Mode

Reception cannot be resumed while a receive error flag is set to 1. Accordingly, clear the OER, FER, PER, and RDRF bits to 0 before resuming reception. Figure 14.14 shows a sample flowchart for serial data reception.

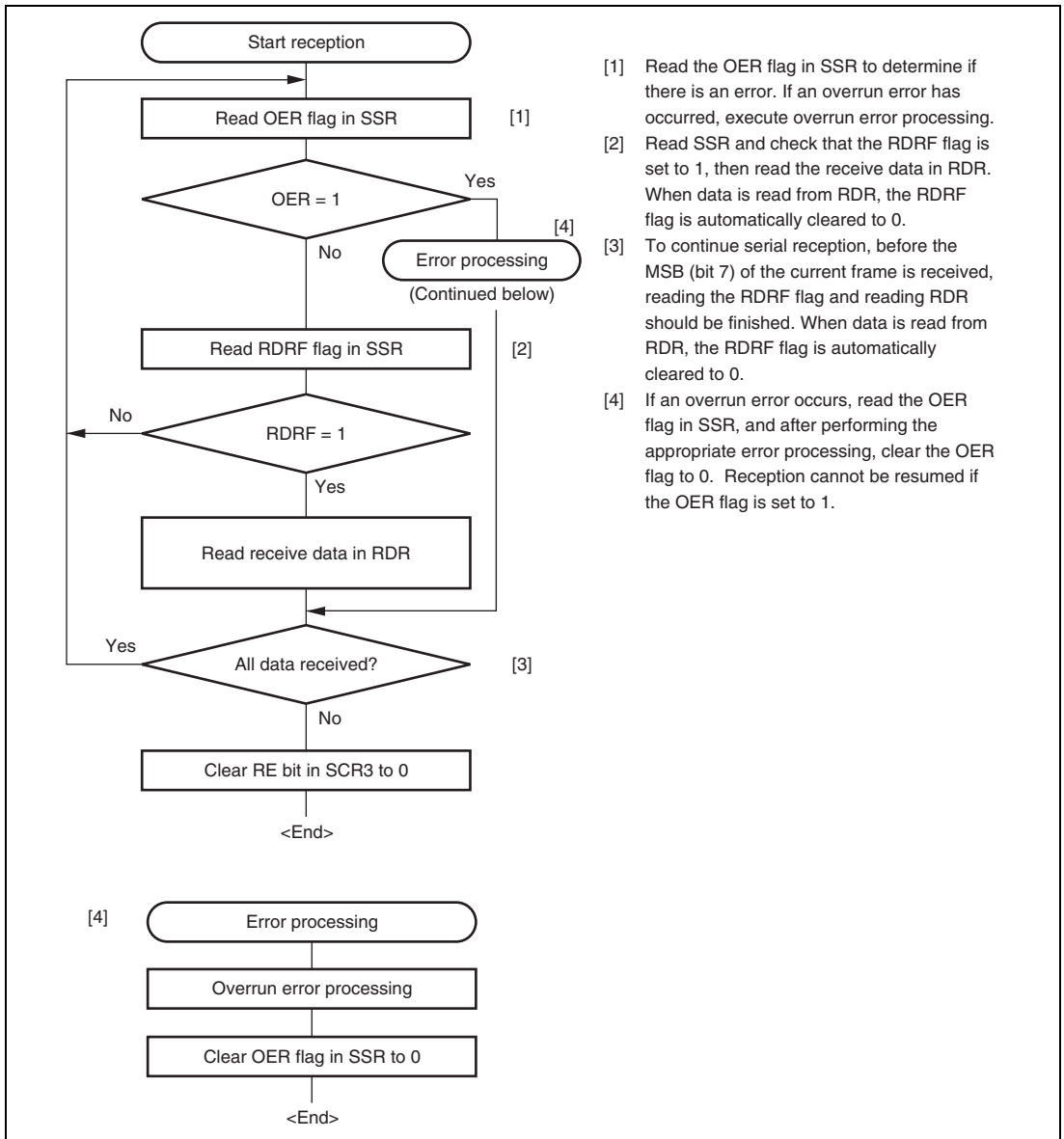

Figure 14.14 Sample Serial Reception Flowchart (Clocked Synchronous Mode)

14.5.5 Simultaneous Serial Data Transmission and Reception

Figure 14.15 shows a sample flowchart for simultaneous serial transmit and receive operations. The following procedure should be used for simultaneous serial data transmit and receive operations. To switch from transmit mode to simultaneous transmit and receive mode, after checking that SCI3 has finished transmission and the TDRE and TEND flags are set to 1, clear TE to 0. Then simultaneously set TE and RE to 1 with a single instruction. To switch from receive mode to simultaneous transmit and receive mode, after checking that SCI3 has finished reception, clear RE to 0. Then after checking that the RDRF and receive error flags (OER, FER, and PER) are cleared to 0, simultaneously set TE and RE to 1 with a single instruction.

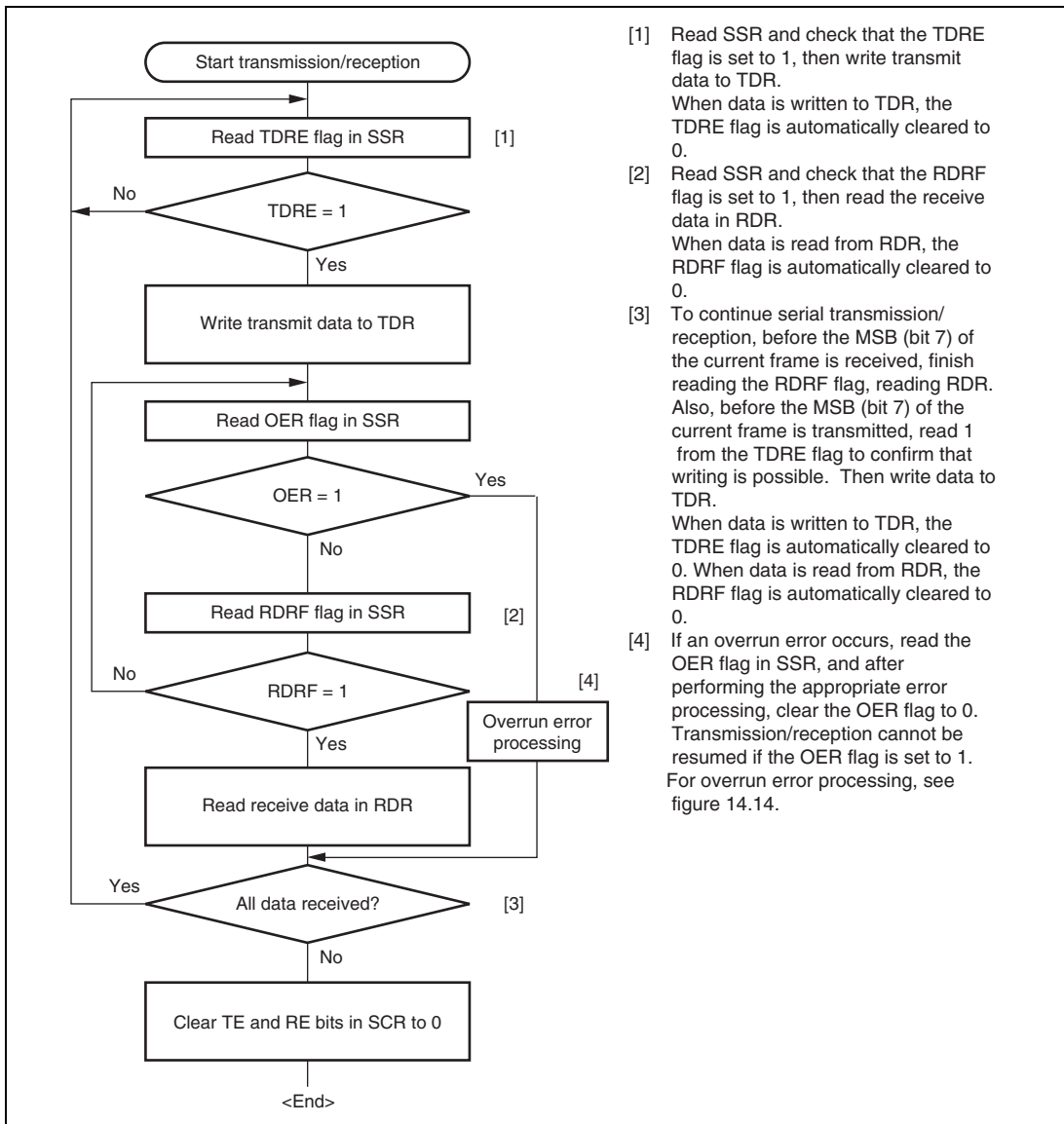

Figure 14.15 Sample Flowchart of Simultaneous Serial Transmit and Receive Operations (Clocked Synchronous Mode)

14.6 Multiprocessor Communication Function

Use of the multiprocessor communication function enables data transfer between a number of processors sharing communication lines by asynchronous serial communication using the multiprocessor format, in which a multiprocessor bit is added to the transfer data. When multiprocessor communication is performed, each receiving station is addressed by a unique ID code. The serial communication cycle consists of two component cycles; an ID transmission cycle that specifies the receiving station, and a data transmission cycle. The multiprocessor bit is used to differentiate between the ID transmission cycle and the data transmission cycle. If the multiprocessor bit is 1, the cycle is an ID transmission cycle; if the multiprocessor bit is 0, the cycle is a data transmission cycle. Figure 14.16 shows an example of inter-processor communication using the multiprocessor format. The transmitting station first sends the ID code of the receiving station with which it wants to perform serial communication as data with a 1 multiprocessor bit added. It then sends transmit data as data with a 0 multiprocessor bit added. When data with a 1 multiprocessor bit is received, the receiving station compares that data with its own ID. The station whose ID matches then receives the data sent next. Stations whose IDs do not match continue to skip data until data with a 1 multiprocessor bit is again received.

SCI3 uses the MPIE bit in SCR3 to implement this function. When the MPIE bit is set to 1, transfer of receive data from RSR to RDR, error flag detection, and setting the SSR status flags, RDRF, FER, and OER, to 1, are inhibited until data with a 1 multiprocessor bit is received. On reception of a receive character with a 1 multiprocessor bit, the MPBR bit in SSR is set to 1 and the MPIE bit is automatically cleared, thus normal reception is resumed. If the RIE bit in SCR3 is set to 1 at this time, an RXI interrupt is generated.

When the multiprocessor format is selected, the parity bit setting is rendered invalid. All other bit settings are the same as those in normal asynchronous mode. The clock used for multiprocessor communication is the same as that in normal asynchronous mode.

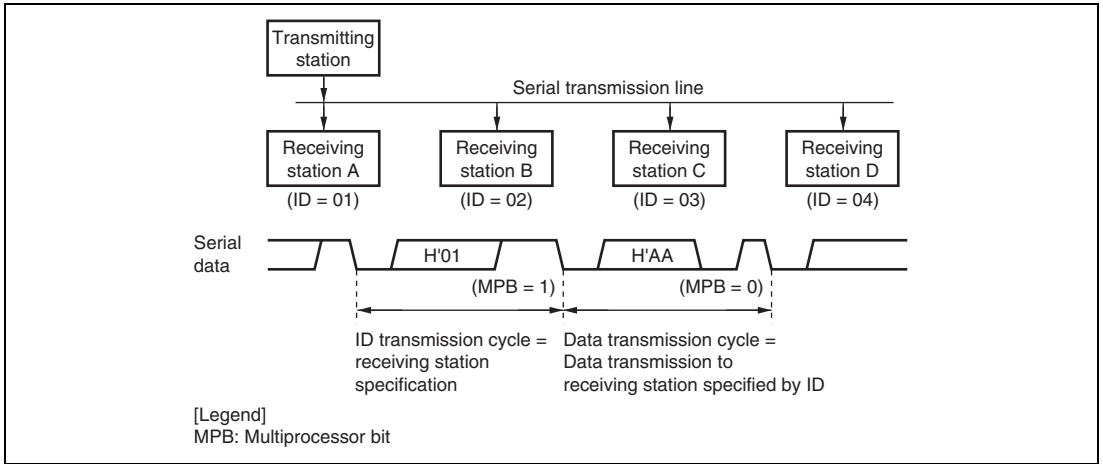

**Figure 14.16 Example of Inter-Processor Communication Using Multiprocessor Format
(Transmission of Data H'AA to Receiving Station A)**

14.6.1 Multiprocessor Serial Data Transmission

Figure 14.17 shows a sample flowchart for multiprocessor serial data transmission. For an ID transmission cycle, set the MPBT bit in SSR to 1 before transmission. For a data transmission cycle, clear the MPBT bit in SSR to 0 before transmission. All other SCI3 operations are the same as those in asynchronous mode.

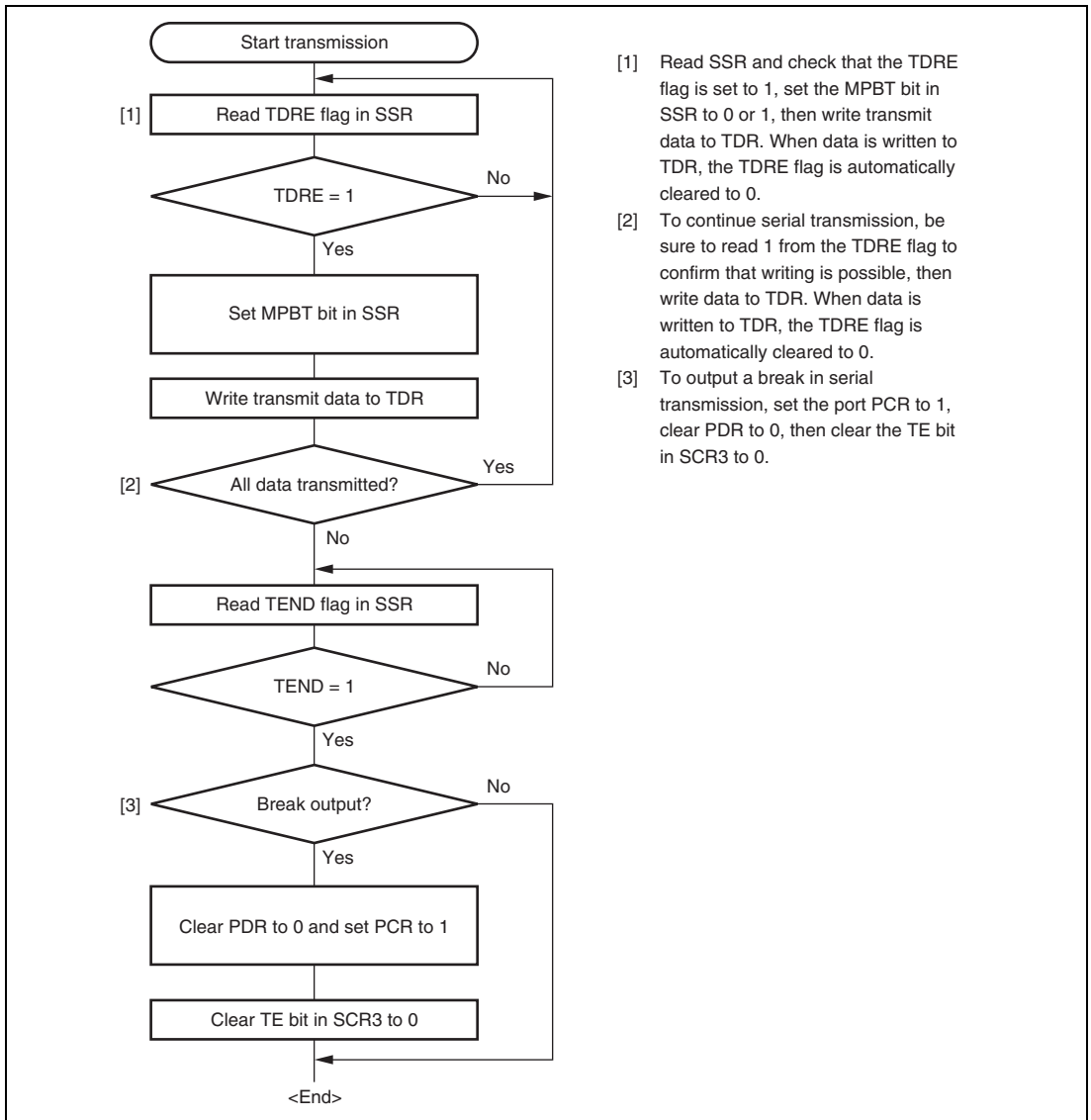
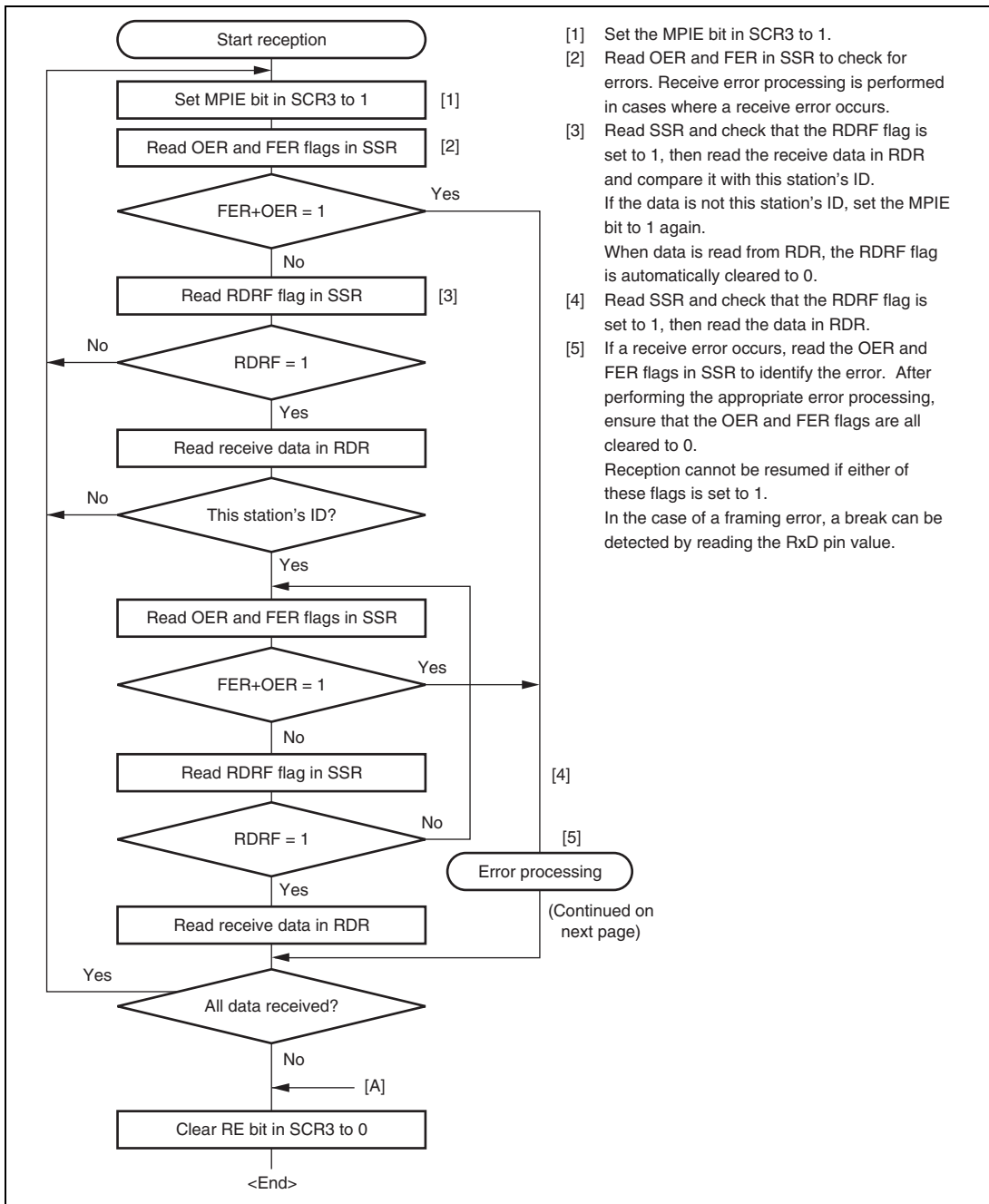

Figure 14.17 Sample Multiprocessor Serial Transmission Flowchart

14.6.2 Multiprocessor Serial Data Reception

Figure 14.18 shows a sample flowchart for multiprocessor serial data reception. If the MPIE bit in SCR3 is set to 1, data is skipped until data with a 1 multiprocessor bit is sent. On receiving data with a 1 multiprocessor bit, the receive data is transferred to RDR. An RXI interrupt request is generated at this time. All other SCI3 operations are the same as those in asynchronous mode. Figure 14.19 shows an example of SCI3 operation for multiprocessor format reception.



- [1] Set the MPIE bit in SCR3 to 1.
- [2] Read OER and FER in SSR to check for errors. Receive error processing is performed in cases where a receive error occurs.
- [3] Read SSR and check that the RDRF flag is set to 1, then read the receive data in RDR and compare it with this station's ID. If the data is not this station's ID, set the MPIE bit to 1 again. When data is read from RDR, the RDRF flag is automatically cleared to 0.
- [4] Read SSR and check that the RDRF flag is set to 1, then read the data in RDR.
- [5] If a receive error occurs, read the OER and FER flags in SSR to identify the error. After performing the appropriate error processing, ensure that the OER and FER flags are all cleared to 0. Reception cannot be resumed if either of these flags is set to 1. In the case of a framing error, a break can be detected by reading the RxD pin value.

Figure 14.18 Sample Multiprocessor Serial Reception Flowchart (1)

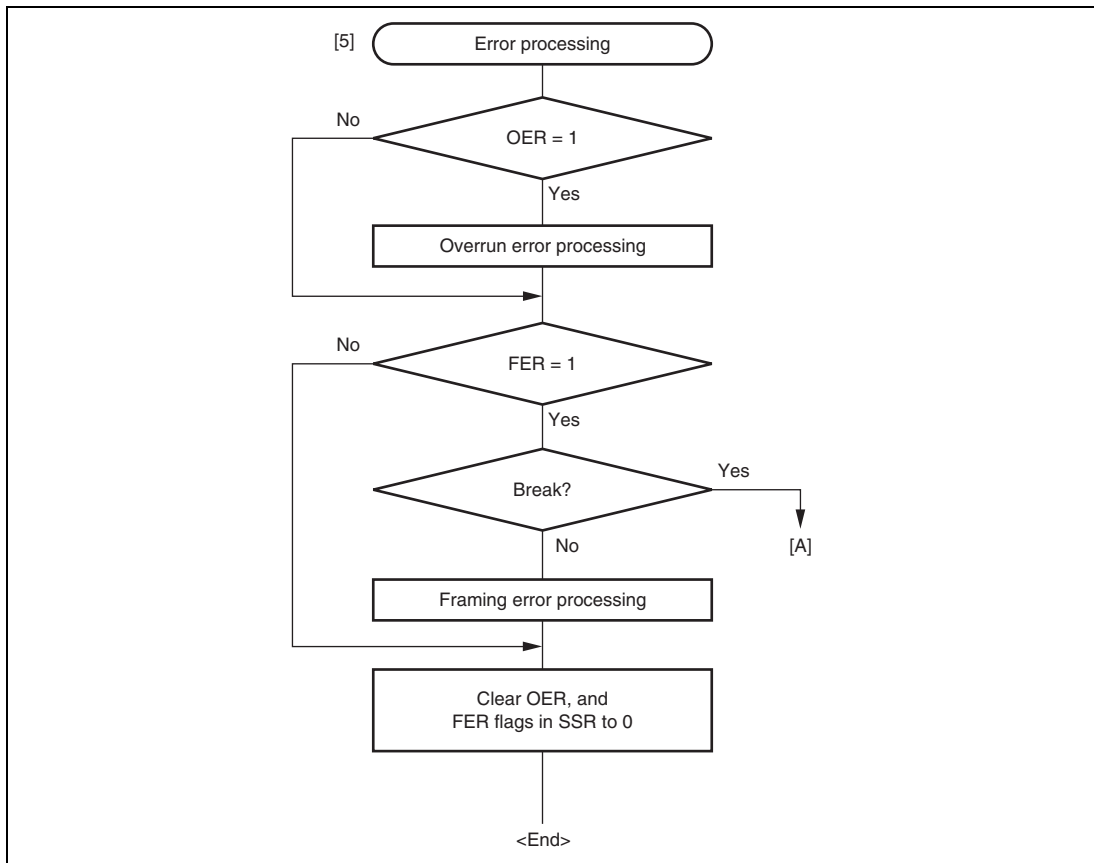

Figure 14.18 Sample Multiprocessor Serial Reception Flowchart (2)

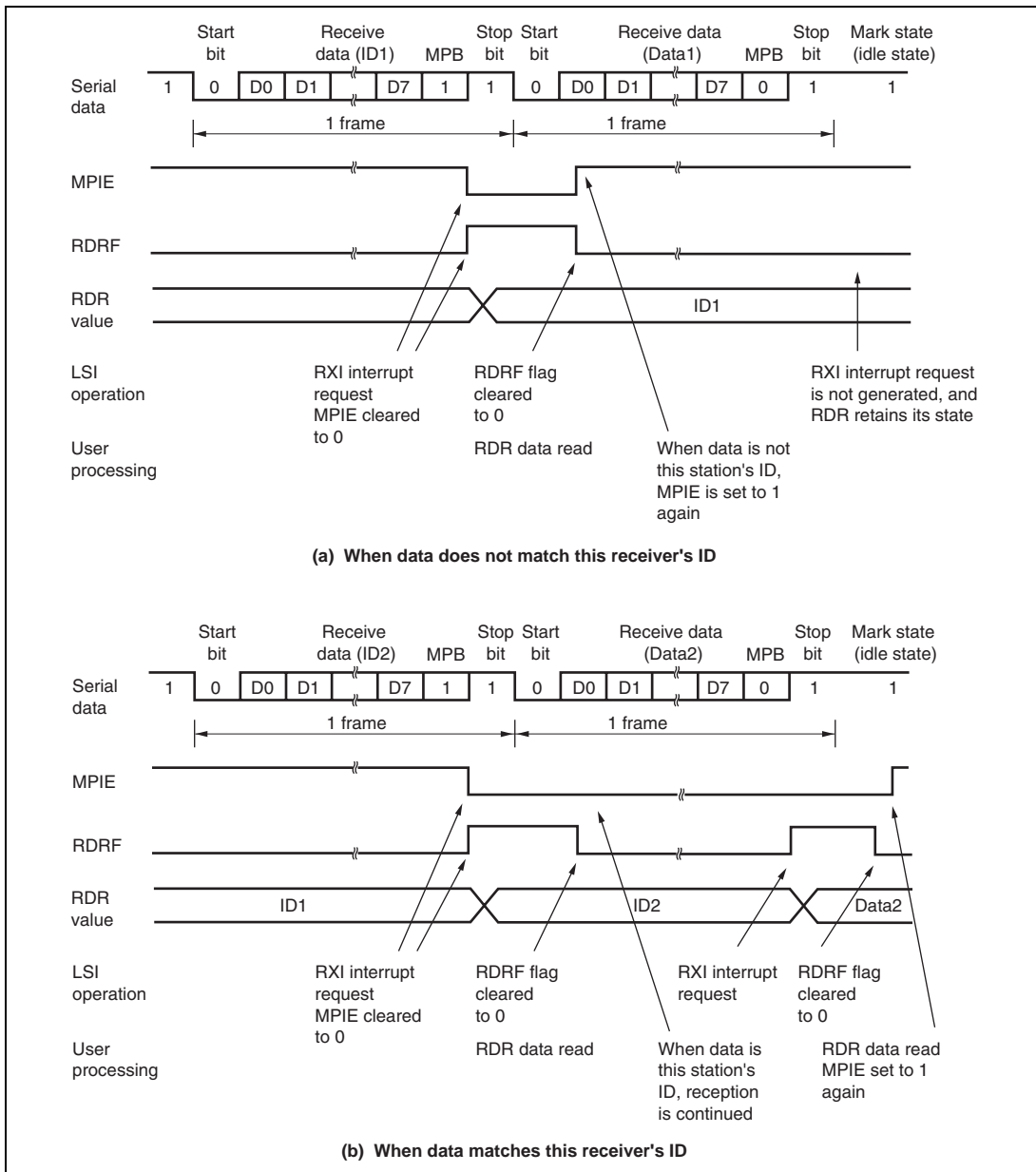

Figure 14.19 Example of SCI3 Reception Using Multiprocessor Format (Example with 8-Bit Data, Multiprocessor Bit, One Stop Bit)

14.7 Interrupts

SCI3 creates the following six interrupt requests: transmission end, transmit data empty, receive data full, and receive errors (overrun error, framing error, and parity error). Table 14.6 shows the interrupt sources.

Table 14.6 SCI3 Interrupt Requests

Interrupt Requests	Abbreviation	Interrupt Sources
Receive Data Full	RXI	Setting RDRF in SSR
Transmit Data Empty	TXI	Setting TDRE in SSR
Transmission End	TEI	Setting TEND in SSR
Receive Error	ERI	Setting OER, FER, and PER in SSR

The initial value of the TDRE flag in SSR is 1. Thus, when the TIE bit in SCR3 is set to 1 before transferring the transmit data to TDR, a TXI interrupt request is generated even if the transmit data is not ready. The initial value of the TEND flag in SSR is 1. Thus, when the TEIE bit in SCR3 is set to 1 before transferring the transmit data to TDR, a TEI interrupt request is generated even if the transmit data has not been sent. It is possible to make use of the most of these interrupt requests efficiently by transferring the transmit data to TDR in the interrupt routine. To prevent the generation of these interrupt requests (TXI and TEI), set the enable bits (TIE and TEIE) that correspond to these interrupt requests to 1, after transferring the transmit data to TDR.

14.8 Usage Notes

14.8.1 Break Detection and Processing

When framing error detection is performed, a break can be detected by reading the RXD pin value directly. In a break, the input from the RXD pin becomes all 0s, setting the FER flag, and possibly the PER flag. Note that as SCI3 continues the receive operation after receiving a break, even if the FER flag is cleared to 0, it will be set to 1 again.

14.8.2 Mark State and Break Sending

When the TXD bit in PMR1 is 1, the TxD pin is used as an I/O port whose direction (input or output) and level are determined by PCR and PDR. This can be used to set the TxD pin to mark state (high level) or send a break during serial data transmission. To maintain the communication line at mark state until TE is set to 1, set PCR and PDR to 1 respectively, and also set the TXD bit to 1. At this time, the TxD pin becomes an I/O port, and 1 is output from the TxD pin. To send a break during serial data transmission, first set PCR to 1 and clear PDR to 0, and then set the TXD bit to 1. Regardless of the current transmission state, the TxD pin becomes an I/O port, and 0 is output from the TxD pin.

14.8.3 Receive Error Flags and Transmit Operations (Clocked Synchronous Mode Only)

Transmission cannot be started when a receive error flag (OER, PER, or FER) is set to 1, even if the TDRE flag is cleared to 0. Be sure to clear the receive error flags to 0 before starting transmission. Note also that receive error flags cannot be cleared to 0 even if the RE bit is cleared to 0.

14.8.4 Receive Data Sampling Timing and Reception Margin in Asynchronous Mode

In asynchronous mode, SCI3 operates on a basic clock with a frequency of 16 times the transfer rate. In reception, SCI3 samples the falling edge of the start bit using the basic clock, and performs internal synchronization. Receive data is latched internally at the rising edge of the 8th pulse of the basic clock as shown in figure 14.20. Thus, the reception margin in asynchronous mode is given by formula (1) below.

$$M = \left\{ \left(0.5 - \frac{1}{2N} \right) - \frac{D - 0.5}{N} - (L - 0.5) F \right\} \times 100(\%)$$

... Formula (1)

Legend N : Ratio of bit rate to clock (N = 16)

D : Clock duty (D = 0.5 to 1.0)

L : Frame length (L = 9 to 12)

F : Absolute value of clock rate deviation

Assuming values of F (absolute value of clock rate deviation) = 0 and D (clock duty) = 0.5 in formula (1), the reception margin can be given by the formula.

$$M = \{0.5 - 1/(2 \times 16)\} \times 100 [\%] = 46.875\%$$

However, this is only the computed value, and a margin of 20% to 30% should be allowed for in system design.

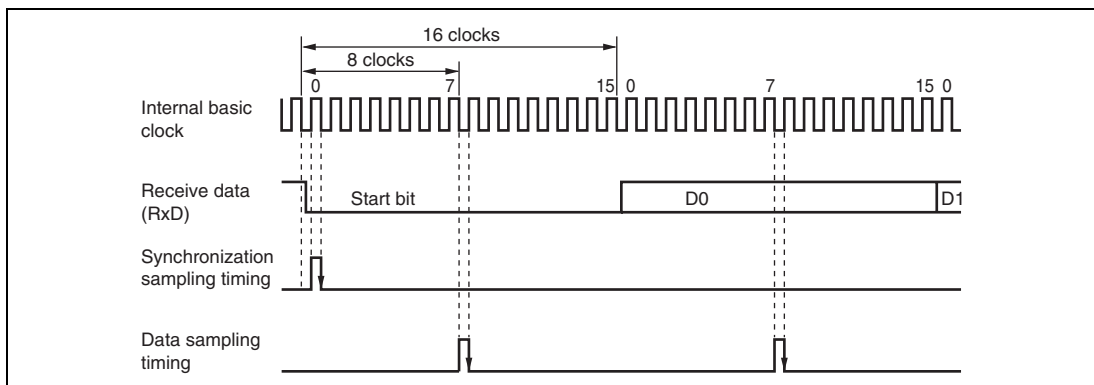

Figure 14.20 Receive Data Sampling Timing in Asynchronous Mode

Section 15 I²C Bus Interface 2 (IIC2)

The I²C bus interface 2 conforms to and provides a subset of the Philips I²C bus (inter-IC bus) interface functions. The register configuration that controls the I²C bus differs partly from the Philips configuration, however.

Figure 15.1 shows a block diagram of the I²C bus interface 2.

Figure 15.2 shows an example of I/O pin connections to external circuits.

15.1 Features

- Selection of I²C format or clocked synchronous serial format
- Continuous transmission/reception

Since the shift register, transmit data register, and receive data register are independent from each other, the continuous transmission/reception can be performed.

I²C bus format:

- Start and stop conditions generated automatically in master mode
- Selection of acknowledge output levels when receiving
- Automatic loading of acknowledge bit when transmitting
- Bit synchronization/wait function

In master mode, the state of SCL is monitored per bit, and the timing is synchronized automatically.

If transmission/reception is not yet possible, set the SCL to low until preparations are completed.

- Six interrupt sources
Transmit data empty (including slave-address match), transmit end, receive data full (including slave-address match), arbitration lost, NACK detection, and stop condition detection
- Direct bus drive
Two pins, SCL and SDA pins, function as NMOS open-drain outputs when the bus drive function is selected.

Clocked synchronous format:

- Four interrupt sources
Transmit-data-empty, transmit-end, receive-data-full, and overrun error

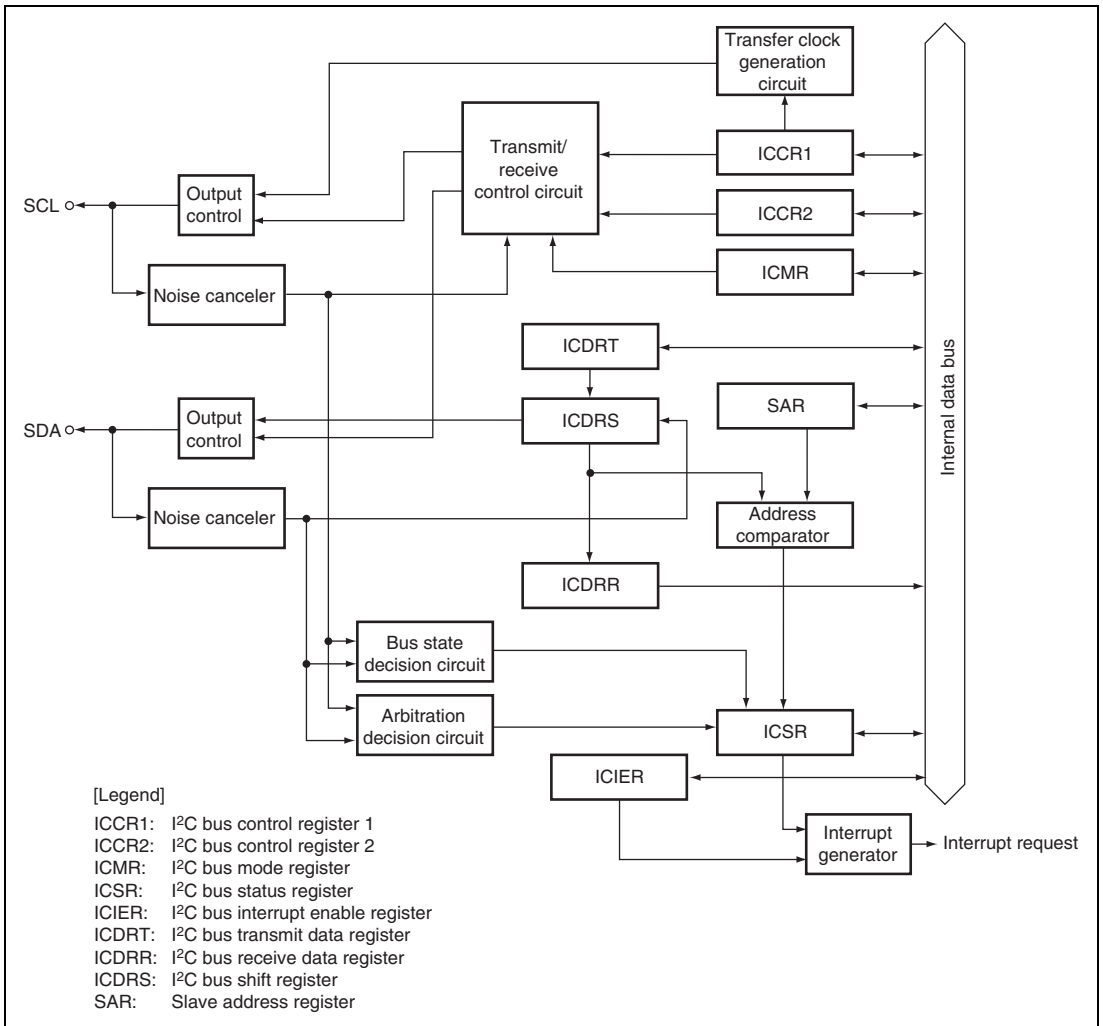

Figure 15.1 Block Diagram of I²C Bus Interface 2

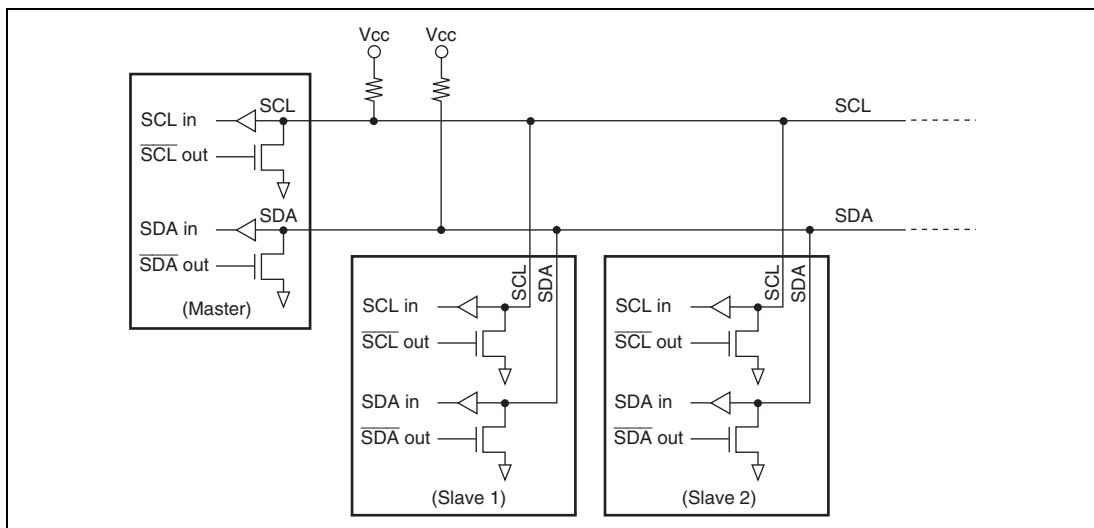

Figure 15.2 External Circuit Connections of I/O Pins

15.2 Input/Output Pins

Table 15.1 summarizes the input/output pins used by the I²C bus interface 2.

Table 15.1 Pin Configuration

Name	Abbreviation	I/O	Function
Serial clock	SCL	I/O	I ² C serial clock input/output
Serial data	SDA	I/O	I ² C serial data input/output

15.3 Register Descriptions

The I²C bus interface 2 has the following registers.

- I²C bus control register 1 (ICCR1)
- I²C bus control register 2 (ICCR2)
- I²C bus mode register (ICMR)
- I²C bus interrupt enable register (ICIER)
- I²C bus status register (ICSR)
- I²C bus slave address register (SAR)
- I²C bus transmit data register (ICDRT)
- I²C bus receive data register (ICDRR)
- I²C bus shift register (ICDRS)

15.3.1 I²C Bus Control Register 1 (ICCR1)

ICCR1 enables or disables the I²C bus interface 2, controls transmission or reception, and selects master or slave mode, transmission or reception, and transfer clock frequency in master mode.

Bit	Bit Name	Initial Value	R/W	Description
7	ICE	0	R/W	<p>I²C Bus Interface Enable</p> <p>0: This module is halted. (SCL and SDA pins are set to port function.)</p> <p>1: This bit is enabled for transfer operations. (SCL and SDA pins are bus drive state.)</p>
6	RCVD	0	R/W	<p>Reception Disable</p> <p>This bit enables or disables the next operation when TRS is 0 and ICDRR is read.</p> <p>0: Enables next reception</p> <p>1: Disables next reception</p>

Bit	Bit Name	Initial Value	R/W	Description
5	MST	0	R/W	Master/Slave Select
4	TRS	0	R/W	Transmit/Receive Select In master mode with the I ² C bus format, when arbitration is lost, MST and TRS are both reset by hardware, causing a transition to slave receive mode. Modification of the TRS bit should be made between transfer frames. After data receive has been started in slave receive mode, when the first seven bits of the receive data agree with the slave address that is set to SAR and the eighth bit is 1, TRS is automatically set to 1. If an overrun error occurs in master mode with the clock synchronous serial format, MST is cleared to 0 and slave receive mode is entered. Operating modes are described below according to MST and TRS combination. When clocked synchronous serial format is selected and MST is 1, clock is output. 00: Slave receive mode 01: Slave transmit mode 10: Master receive mode 11: Master transmit mode
3 to 0	CKS3 to CKS0	All 0	R/W	Transfer Clock Select 3 to 0 These bits should be set according to the necessary transfer rate (see table 15.2) in master mode. In slave mode, these bits are used reservation of the set up time in transmit mode. The time is $10t_{cyc}$ when CKS3 = 0, and $20t_{cyc}$ when CKS3 = 1.

Table 15.2 Transfer Rate

Bit 3 CKS3	Bit 2 CKS2	Bit 1 CKS1	Bit 0 CKS0	Clock	Transfer Rate			
					$\phi = 5 \text{ MHz}$	$\phi = 8 \text{ MHz}$	$\phi = 10 \text{ MHz}$	
0	0	0	0	$\phi/28$	179 kHz	286 kHz	357 kHz	
			1	$\phi/40$	125 kHz	200 kHz	250 kHz	
		1	0	$\phi/48$	104 kHz	167 kHz	208 kHz	
			1	$\phi/64$	78.1 kHz	125 kHz	156 kHz	
		1	0	0	$\phi/80$	62.5 kHz	100 kHz	125 kHz
				1	$\phi/100$	50.0 kHz	80.0 kHz	100 kHz
	1		0	$\phi/112$	44.6 kHz	71.4 kHz	89.3 kHz	
			1	$\phi/128$	39.1 kHz	62.5 kHz	78.1 kHz	
	1	0	0	0	$\phi/56$	89.3 kHz	143 kHz	179 kHz
				1	$\phi/80$	62.5 kHz	100 kHz	125 kHz
			1	0	$\phi/96$	52.1 kHz	83.3 kHz	104 kHz
				1	$\phi/128$	39.1 kHz	62.5 kHz	78.1 kHz
1			0	0	$\phi/160$	31.3 kHz	50.0 kHz	62.5 kHz
				1	$\phi/200$	25.0 kHz	40.0 kHz	50.0 kHz
		1	0	$\phi/224$	22.3 kHz	35.7 kHz	44.6 kHz	
			1	$\phi/256$	19.5 kHz	31.3 kHz	39.1 kHz	

15.3.2 I²C Bus Control Register 2 (ICCR2)

ICCR2 issues start/stop conditions, manipulates the SDA pin, monitors the SCL pin, and controls reset in the control part of the I²C bus interface 2.

Bit	Bit Name	Initial Value	R/W	Description
7	BBSY	0	R/W	<p>Bus Busy</p> <p>This bit enables to confirm whether the I²C bus is occupied or released and to issue start/stop conditions in master mode. With the clocked synchronous serial format, this bit has no meaning. With the I²C bus format, this bit is set to 1 when the SDA level changes from high to low under the condition of SCL = high, assuming that the start condition has been issued. This bit is cleared to 0 when the SDA level changes from low to high under the condition of SCL = high, assuming that the stop condition has been issued. Write 1 to BBSY and 0 to SCP to issue a start condition. Follow this procedure when also re-transmitting a start condition. Write 0 in BBSY and 0 in SCP to issue a stop condition. To issue start/stop conditions, use the MOV instruction.</p>
6	SCP	1	R/W	<p>Start/Stop Issue Condition Disable</p> <p>The SCP bit controls the issue of start/stop conditions in master mode.</p> <p>To issue a start condition, write 1 in BBSY and 0 in SCP. A retransmit start condition is issued in the same way. To issue a stop condition, write 0 in BBSY and 0 in SCP. This bit is always read as 1. If 1 is written, the data is not stored.</p>
5	SDAO	1	R/W	<p>SDA Output Value Control</p> <p>This bit is used with SDAOP when modifying output level of SDA. This bit should not be manipulated during transfer.</p> <p>0: When reading, SDA pin outputs low. When writing, SDA pin is changed to output low.</p> <p>1: When reading, SDA pin outputs high. When writing, SDA pin is changed to output Hi-Z (outputs high by external pull-up resistance).</p>
4	SDAOP	1	R/W	<p>SDAO Write Protect</p> <p>This bit controls change of output level of the SDA pin by modifying the SDAO bit. To change the output level, clear SDAO and SDAOP to 0 or set SDAO to 1 and clear SDAOP to 0 by the MOV instruction. This bit is always read as 1.</p>

Bit	Bit Name	Initial Value	R/W	Description
3	SCLO	1	R	This bit monitors SCL output level. When SCLO is 1, SCL pin outputs high. When SCLO is 0, SCL pin outputs low.
2	—	1	—	Reserved This bit is always read as 1.
1	IICRST	0	R/W	IIC Control Part Reset This bit resets the control part except for I ² C registers. If this bit is set to 1 when hang-up occurs because of communication failure during I ² C operation, I ² C control part can be reset without setting ports and initializing registers.
0	—	1	—	Reserved This bit is always read as 1.

15.3.3 I²C Bus Mode Register (ICMR)

ICMR selects whether the MSB or LSB is transferred first, performs master mode wait control, and selects the transfer bit count.

Bit	Bit Name	Initial Value	R/W	Description
7	MLS	0	R/W	MSB-First/LSB-First Select 0: MSB-first 1: LSB-first Set this bit to 0 when the I ² C bus format is used.
6	WAIT	0	R/W	Wait Insertion Bit In master mode with the I ² C bus format, this bit selects whether to insert a wait after data transfer except the acknowledge bit. When WAIT is set to 1, after the fall of the clock for the final data bit, low period is extended for two transfer clocks. If WAIT is cleared to 0, data and acknowledge bits are transferred consecutively with no wait inserted. The setting of this bit is invalid in slave mode with the I ² C bus format or with the clocked synchronous serial format.
5, 4	—	All 1	—	Reserved These bits are always read as 1.

Bit	Bit Name	Initial Value	R/W	Description																		
3	BCWP	1	R/W	<p>BC Write Protect</p> <p>This bit controls the BC2 to BC0 modifications. When modifying BC2 to BC0, this bit should be cleared to 0 and use the MOV instruction. In clock synchronous serial mode, BC should not be modified.</p> <p>0: When writing, values of BC2 to BC0 are set. 1: When reading, 1 is always read.</p> <p>When writing, settings of BC2 to BC0 are invalid.</p>																		
2	BC2	0	R/W	Bit Counter 2 to 0																		
1	BC1	0	R/W	These bits specify the number of bits to be transferred next.																		
0	BC0	0	R/W	<p>When read, the remaining number of transfer bits is indicated. With the I²C bus format, the data is transferred with one addition acknowledge bit. Bit BC2 to BC0 settings should be made during an interval between transfer frames. If bits BC2 to BC0 are set to a value other than 000, the setting should be made while the SCL pin is low. The value returns to 000 at the end of a data transfer, including the acknowledge bit. With the clock synchronous serial format, these bits should not be modified.</p> <table border="0"> <thead> <tr> <th>I²C Bus Format</th> <th>Clock Synchronous Serial Format</th> </tr> </thead> <tbody> <tr> <td>000: 9 bits</td> <td>000: 8 bits</td> </tr> <tr> <td>001: 2 bits</td> <td>001: 1 bits</td> </tr> <tr> <td>010: 3 bits</td> <td>010: 2 bits</td> </tr> <tr> <td>011: 4 bits</td> <td>011: 3 bits</td> </tr> <tr> <td>100: 5 bits</td> <td>100: 4 bits</td> </tr> <tr> <td>101: 6 bits</td> <td>101: 5 bits</td> </tr> <tr> <td>110: 7 bits</td> <td>110: 6 bits</td> </tr> <tr> <td>111: 8 bits</td> <td>111: 7 bits</td> </tr> </tbody> </table>	I ² C Bus Format	Clock Synchronous Serial Format	000: 9 bits	000: 8 bits	001: 2 bits	001: 1 bits	010: 3 bits	010: 2 bits	011: 4 bits	011: 3 bits	100: 5 bits	100: 4 bits	101: 6 bits	101: 5 bits	110: 7 bits	110: 6 bits	111: 8 bits	111: 7 bits
I ² C Bus Format	Clock Synchronous Serial Format																					
000: 9 bits	000: 8 bits																					
001: 2 bits	001: 1 bits																					
010: 3 bits	010: 2 bits																					
011: 4 bits	011: 3 bits																					
100: 5 bits	100: 4 bits																					
101: 6 bits	101: 5 bits																					
110: 7 bits	110: 6 bits																					
111: 8 bits	111: 7 bits																					

15.3.4 I²C Bus Interrupt Enable Register (ICIER)

ICIER enables or disables interrupt sources and acknowledge bits, sets acknowledge bits to be transferred, and confirms acknowledge bits to be received.

Bit	Bit Name	Initial Value	R/W	Description
7	TIE	0	R/W	<p>Transmit Interrupt Enable</p> <p>When the TDRE bit in ICSR is set to 1, this bit enables or disables the transmit data empty interrupt (TXI).</p> <p>0: Transmit data empty interrupt request (TXI) is disabled. 1: Transmit data empty interrupt request (TXI) is enabled.</p>
6	TEIE	0	R/W	<p>Transmit End Interrupt Enable</p> <p>This bit enables or disables the transmit end interrupt (TEI) at the rising of the ninth clock while the TDRE bit in ICSR is 1. TEI can be canceled by clearing the TEND bit or the TEIE bit to 0.</p> <p>0: Transmit end interrupt request (TEI) is disabled. 1: Transmit end interrupt request (TEI) is enabled.</p>
5	RIE	0	R/W	<p>Receive Interrupt Enable</p> <p>This bit enables or disables the receive data full interrupt request (RXI) and the overrun error interrupt request (ERI) with the clocked synchronous format, when a receive data is transferred from ICDRS to ICRRR and the RDRF bit in ICSR is set to 1. RXI can be canceled by clearing the RDRF or RIE bit to 0.</p> <p>0: Receive data full interrupt request (RXI) and overrun error interrupt request (ERI) with the clocked synchronous format are disabled. 1: Receive data full interrupt request (RXI) and overrun error interrupt request (ERI) with the clocked synchronous format are enabled.</p>

Bit	Bit Name	Initial Value	R/W	Description
4	NAKIE	0	R/W	<p>NACK Receive Interrupt Enable</p> <p>This bit enables or disables the NACK receive interrupt request (NAKI) and the overrun error (setting of the OVE bit in ICSR) interrupt request (ERI) with the clocked synchronous format, when the NACKF and AL bits in ICSR are set to 1. NAKI can be canceled by clearing the NACKF, OVE, or NAKIE bit to 0.</p> <p>0: NACK receive interrupt request (NAKI) is disabled. 1: NACK receive interrupt request (NAKI) is enabled.</p>
3	STIE	0	R/W	<p>Stop Condition Detection Interrupt Enable</p> <p>0: Stop condition detection interrupt request (STPI) is disabled. 1: Stop condition detection interrupt request (STPI) is enabled.</p>
2	ACKE	0	R/W	<p>Acknowledge Bit Judgement Select</p> <p>0: The value of the receive acknowledge bit is ignored, and continuous transfer is performed. 1: If the receive acknowledge bit is 1, continuous transfer is halted.</p>
1	ACKBR	0	R	<p>Receive Acknowledge</p> <p>In transmit mode, this bit stores the acknowledge data that are returned by the receive device. This bit cannot be modified.</p> <p>0: Receive acknowledge = 0 1: Receive acknowledge = 1</p>
0	ACKBT	0	R/W	<p>Transmit Acknowledge</p> <p>In receive mode, this bit specifies the bit to be sent at the acknowledge timing.</p> <p>0: 0 is sent at the acknowledge timing. 1: 1 is sent at the acknowledge timing.</p>

15.3.5 I²C Bus Status Register (ICSR)

ICSR performs confirmation of interrupt request flags and status.

Bit	Bit Name	Initial Value	R/W	Description
7	TDRE	0	R/W	Transmit Data Register Empty [Setting conditions] <ul style="list-style-type: none"> • When data is transferred from ICDRT to ICDRS and ICDRT becomes empty • When TRS is set • When a start condition (including re-transfer) has been issued • When transmit mode is entered from receive mode in slave mode [Clearing conditions] <ul style="list-style-type: none"> • When 0 is written in TDRE after reading TDRE = 1 • When data is written to ICDRT with an instruction
6	TEND	0	R/W	Transmit End [Setting conditions] <ul style="list-style-type: none"> • When the ninth clock of SCL rises with the I²C bus format while the TDRE flag is 1 • When the final bit of transmit frame is sent with the clock synchronous serial format [Clearing conditions] <ul style="list-style-type: none"> • When 0 is written in TEND after reading TEND = 1 • When data is written to ICDRT with an instruction
5	RDRF	0	R/W	Receive Data Register Full [Setting condition] <ul style="list-style-type: none"> • When a receive data is transferred from ICDRS to ICDRR [Clearing conditions] <ul style="list-style-type: none"> • When 0 is written in RDRF after reading RDRF = 1 • When ICDRR is read with an instruction

Bit	Bit Name	Initial Value	R/W	Description
4	NACKF	0	R/W	<p>No Acknowledge Detection Flag</p> <p>[Setting condition]</p> <ul style="list-style-type: none"> When no acknowledge is detected from the receive device in transmission while the ACKE bit in ICIER is 1 <p>[Clearing condition]</p> <ul style="list-style-type: none"> When 0 is written in NACKF after reading NACKF = 1
3	STOP	0	R/W	<p>Stop Condition Detection Flag</p> <p>[Setting conditions]</p> <ul style="list-style-type: none"> In master mode, when a stop condition is detected after frame transfer In slave mode, when a stop condition is detected after the general call address or the first byte slave address, next to detection of start condition, accords with the address set in SAR <p>[Clearing condition]</p> <ul style="list-style-type: none"> When 0 is written in STOP after reading STOP = 1
2	AL/OVE	0	R/W	<p>Arbitration Lost Flag/Overrun Error Flag</p> <p>This flag indicates that arbitration was lost in master mode with the I²C bus format and that the final bit has been received while RDRF = 1 with the clocked synchronous format.</p> <p>When two or more master devices attempt to seize the bus at nearly the same time, if the I²C bus interface detects data differing from the data it sent, it sets AL to 1 to indicate that the bus has been taken by another master.</p> <p>[Setting conditions]</p> <ul style="list-style-type: none"> If the internal SDA and SDA pin disagree at the rise of SCL in master transmit mode When the SDA pin outputs high in master mode while a start condition is detected When the final bit is received with the clocked synchronous format while RDRF = 1 <p>[Clearing condition]</p> <ul style="list-style-type: none"> When 0 is written in AL/OVE after reading AL/OVE=1

Bit	Bit Name	Initial Value	R/W	Description
1	AAS	0	R/W	<p>Slave Address Recognition Flag</p> <p>In slave receive mode, this flag is set to 1 if the first frame following a start condition matches bits SVA6 to SVA0 in SAR.</p> <p>[Setting conditions]</p> <ul style="list-style-type: none"> When the slave address is detected in slave receive mode When the general call address is detected in slave receive mode. <p>[Clearing condition]</p> <ul style="list-style-type: none"> When 0 is written in AAS after reading AAS=1
0	ADZ	0	R/W	<p>General Call Address Recognition Flag</p> <p>This bit is valid in I²C bus format slave receive mode.</p> <p>[Setting condition]</p> <ul style="list-style-type: none"> When the general call address is detected in slave receive mode <p>[Clearing condition]</p> <ul style="list-style-type: none"> When 0 is written in ADZ after reading ADZ=1

15.3.6 Slave Address Register (SAR)

SAR selects the communication format and sets the slave address. When the chip is in slave mode with the I²C bus format, if the upper 7 bits of SAR match the upper 7 bits of the first frame received after a start condition, the chip operates as the slave device.

Bit	Bit Name	Initial Value	R/W	Description
7 to 1	SVA6 to SVA0	All 0	R/W	<p>Slave Address 6 to 0</p> <p>These bits set a unique address in bits SVA6 to SVA0, differing from the addresses of other slave devices connected to the I²C bus.</p>
0	FS	0	R/W	<p>Format Select</p> <p>0: I²C bus format is selected.</p> <p>1: Clocked synchronous serial format is selected.</p>

15.3.7 I²C Bus Transmit Data Register (ICDRT)

ICDRT is an 8-bit readable/writable register that stores the transmit data. When ICDRT detects the space in the shift register (ICDRS), it transfers the transmit data which is written in ICDRT to ICDRS and starts transferring data. If the next transfer data is written to ICDRT during transferring data of ICDRS, continuous transfer is possible. If the MLS bit of ICMR is set to 1 and when the data is written to ICDRT, the MSB/LSB inverted data is read. The initial value of ICDRT is H'FF.

15.3.8 I²C Bus Receive Data Register (ICDRR)

ICDRR is an 8-bit register that stores the receive data. When data of one byte is received, ICDRR transfers the receive data from ICDRS to ICDRR and the next data can be received. ICDRR is a receive-only register, therefore the CPU cannot write to this register. The initial value of ICDRR is H'FF.

15.3.9 I²C Bus Shift Register (ICDRS)

ICDRS is a register that is used to transfer/receive data. In transmission, data is transferred from ICDRT to ICDRS and the data is sent from the SDA pin. In reception, data is transferred from ICDRS to ICDRR after data of one byte is received. This register cannot be read directly from the CPU.

15.4 Operation

The I²C bus interface can communicate either in I²C bus mode or clocked synchronous serial mode by setting FS in SAR.

15.4.1 I²C Bus Format

Figure 15.3 shows the I²C bus formats. Figure 15.4 shows the I²C bus timing. The first frame following a start condition always consists of 8 bits.

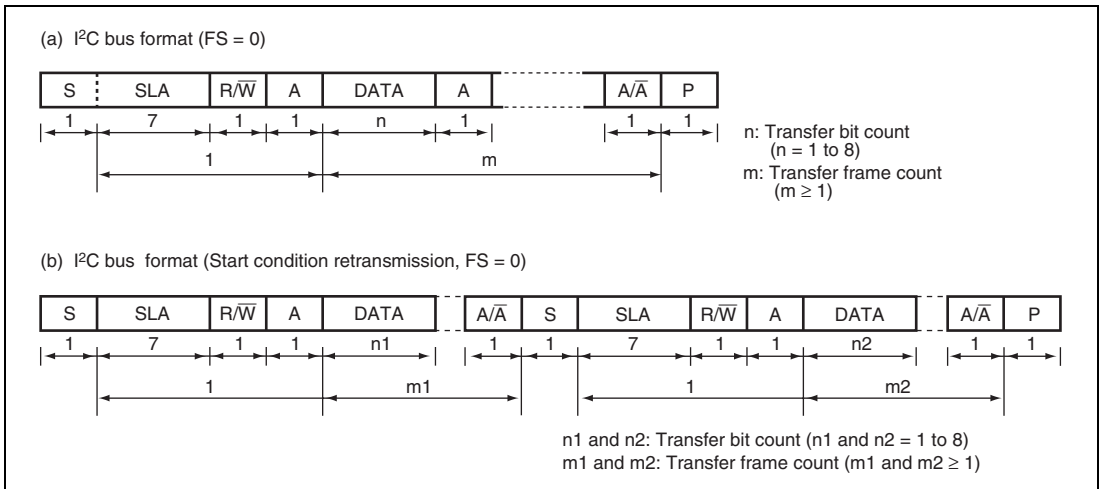

Figure 15.3 I²C Bus Formats

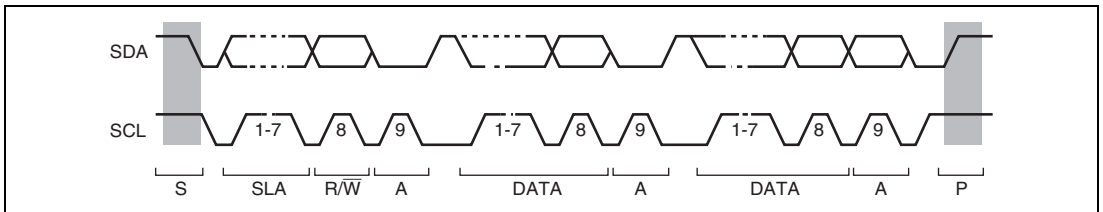

Figure 15.4 I²C Bus Timing

[Legend]

- S: Start condition. The master device drives SDA from high to low while SCL is high.
- SLA: Slave address
- R/W: Indicates the direction of data transfer: from the slave device to the master device when R/W is 1, or from the master device to the slave device when R/W is 0.
- A: Acknowledge. The receive device drives SDA to low.
- DATA: Transfer data
- P: Stop condition. The master device drives SDA from low to high while SCL is high.

15.4.2 Master Transmit Operation

In master transmit mode, the master device outputs the transmit clock and transmit data, and the slave device returns an acknowledge signal. For master transmit mode operation timing, refer to figures 15.5 and 15.6. The transmission procedure and operations in master transmit mode are described below.

1. Set the ICE bit in ICCR1 to 1. Set the MLS and WAIT bits in ICMR and the CKS3 to CKS0 bits in ICCR1 to 1. (Initial setting)
2. Read the BBSY flag in ICCR2 to confirm that the bus is free. Set the MST and TRS bits in ICCR1 to select master transmit mode. Then, write 1 to BBSY and 0 to SCP using MOV instruction. (Start condition issued) This generates the start condition.
3. After confirming that TDRE in ICSR has been set, write the transmit data (the first byte data show the slave address and R/\overline{W}) to ICDRT. At this time, TDRE is automatically cleared to 0, and data is transferred from ICDRT to ICDRS. TDRE is set again.
4. When transmission of one byte data is completed while TDRE is 1, TEND in ICSR is set to 1 at the rise of the 9th transmit clock pulse. Read the ACKBR bit in ICIER, and confirm that the slave device has been selected. Then, write second byte data to ICDRT. When ACKBR is 1, the slave device has not been acknowledged, so issue the stop condition. To issue the stop condition, write 0 to BBSY and SCP using MOV instruction. SCL is fixed low until the transmit data is prepared or the stop condition is issued.
5. The transmit data after the second byte is written to ICDRT every time TDRE is set.
6. Write the number of bytes to be transmitted to ICDRT. Wait until TEND is set (the end of last byte data transmission) while TDRE is 1, or wait for NACK (NACKF in ICSR = 1) from the receive device while ACKE in ICIER is 1. Then, issue the stop condition to clear TEND or NACKF.
7. When the STOP bit in ICSR is set to 1, the operation returns to the slave receive mode.

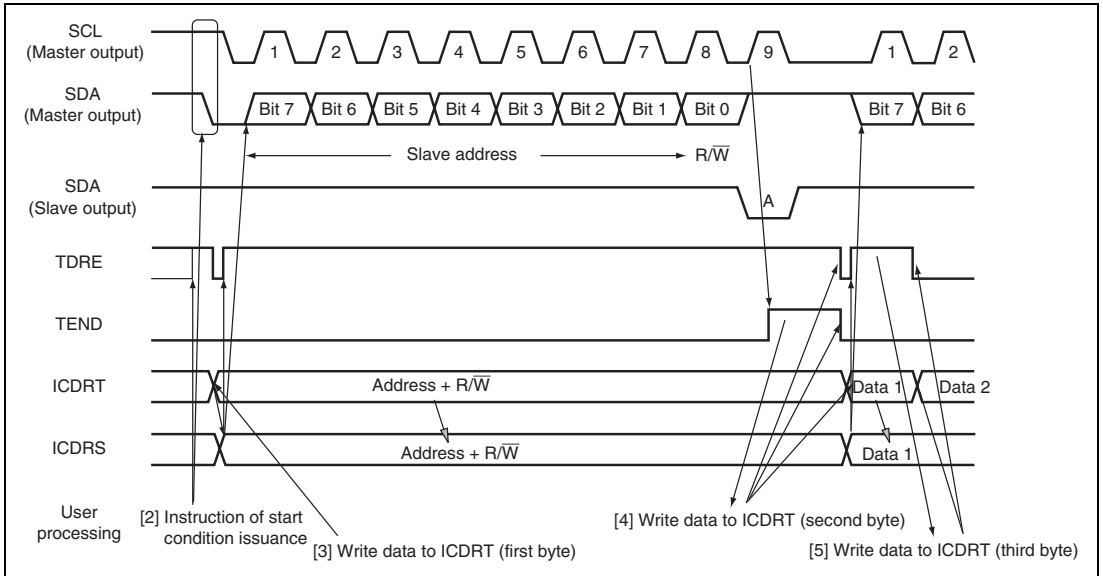

Figure 15.5 Master Transmit Mode Operation Timing (1)

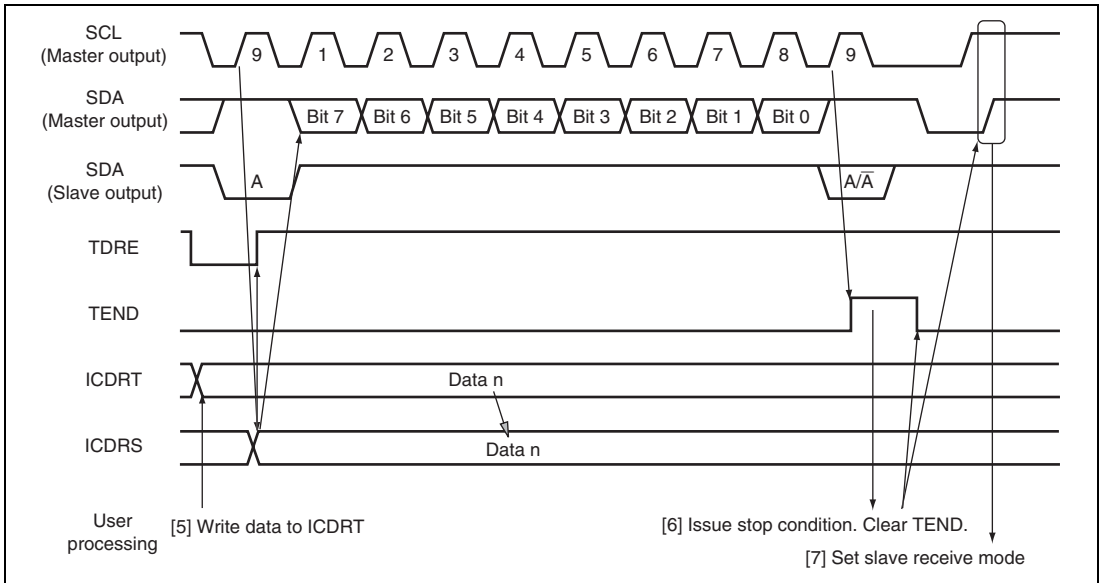

Figure 15.6 Master Transmit Mode Operation Timing (2)

15.4.3 Master Receive Operation

In master receive mode, the master device outputs the receive clock, receives data from the slave device, and returns an acknowledge signal. For master receive mode operation timing, refer to figures 15.7 and 15.8. The reception procedure and operations in master receive mode are shown below.

1. Clear the TEND bit in ICSR to 0, then clear the TRS bit in ICCR1 to 0 to switch from master transmit mode to master receive mode. Then, clear the TDRE bit to 0.
2. When ICDRR is read (dummy data read), reception is started, and the receive clock is output, and data received, in synchronization with the internal clock. The master device outputs the level specified by ACKBT in ICIER to SDA, at the 9th receive clock pulse.
3. After the reception of first frame data is completed, the RDRF bit in ICST is set to 1 at the rise of 9th receive clock pulse. At this time, the receive data is read by reading ICDRR, and RDRF is cleared to 0.
4. The continuous reception is performed by reading ICDRR every time RDRF is set. If 8th receive clock pulse falls after reading ICDRR by the other processing while RDRF is 1, SCL is fixed low until ICDRR is read.
5. If next frame is the last receive data, set the RCVD bit in ICCR1 to 1 before reading ICDRR. This enables the issuance of the stop condition after the next reception.
6. When the RDRF bit is set to 1 at rise of the 9th receive clock pulse, issue the stage condition.
7. When the STOP bit in ICSR is set to 1, read ICDRR. Then clear the RCVD bit to 0.
8. The operation returns to the slave receive mode.

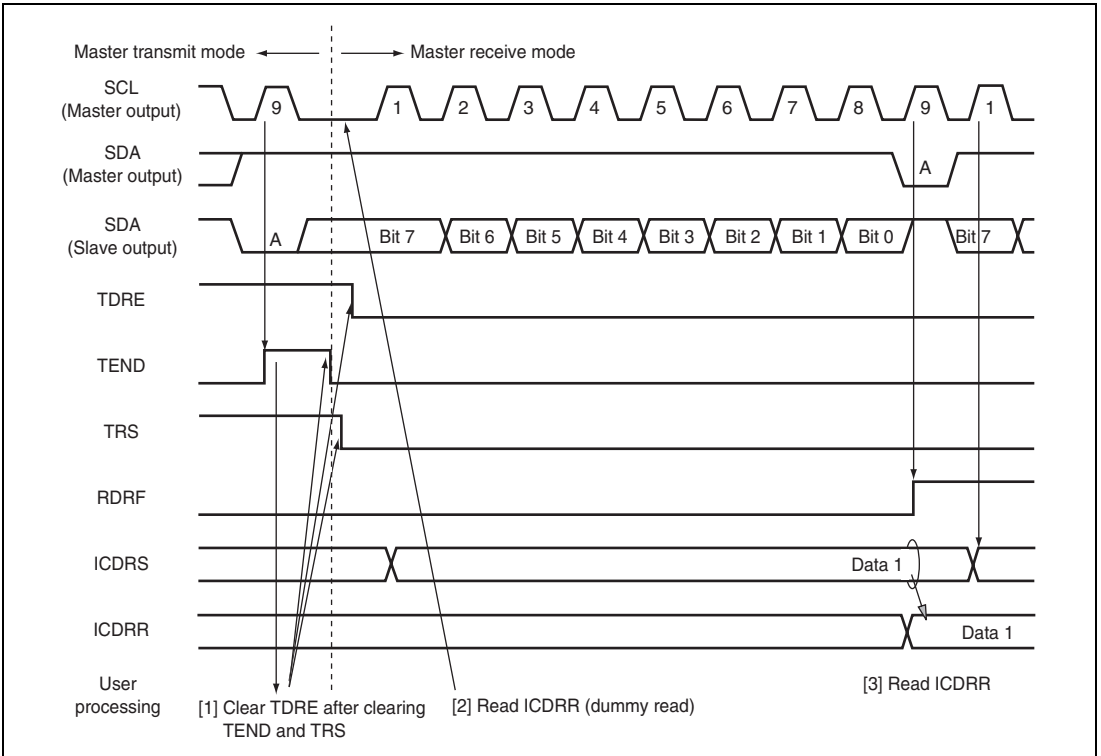

Figure 15.7 Master Receive Mode Operation Timing (1)

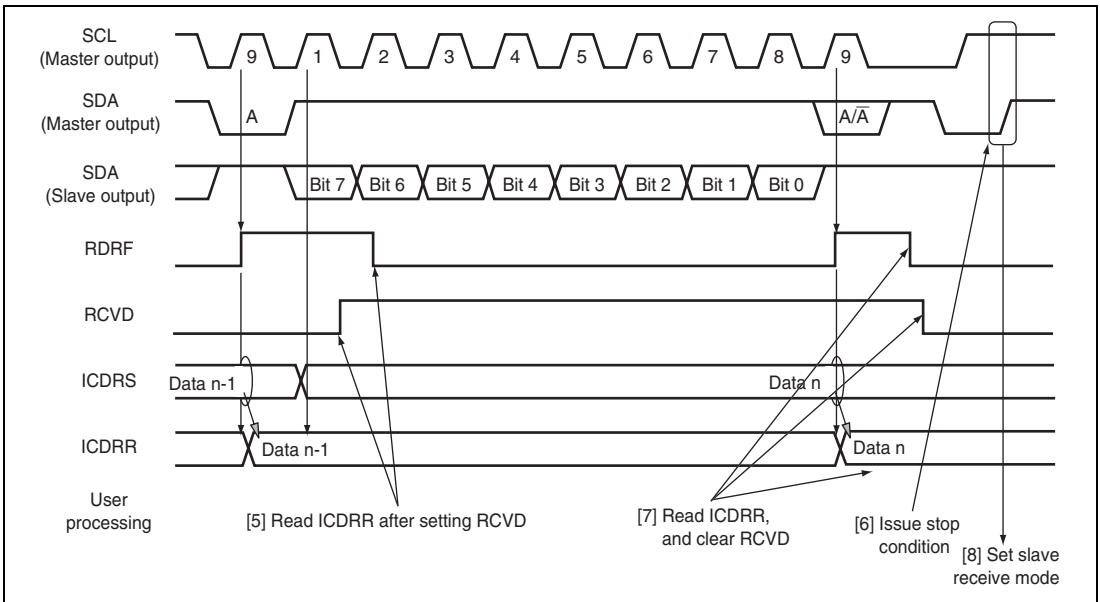

Figure 15.8 Master Receive Mode Operation Timing (2)

15.4.4 Slave Transmit Operation

In slave transmit mode, the slave device outputs the transmit data, while the master device outputs the receive clock and returns an acknowledge signal. For slave transmit mode operation timing, refer to figures 15.9 and 15.10.

The transmission procedure and operations in slave transmit mode are described below.

1. Set the ICE bit in ICCR1 to 1. Set the MLS and WAIT bits in ICMR and the CKS3 to CKS0 bits in ICCR1 to 1. (Initial setting) Set the MST and TRS bits in ICCR1 to select slave receive mode, and wait until the slave address matches.
2. When the slave address matches in the first frame following detection of the start condition, the slave device outputs the level specified by ACKBT in ICIER to SDA, at the rise of the 9th clock pulse. At this time, if the 8th bit data (R/W) is 1, the TRS and ICSR bits in ICCR1 are set to 1, and the mode changes to slave transmit mode automatically. The continuous transmission is performed by writing transmit data to ICDRT every time TDRE is set.
3. If TDRE is set after writing last transmit data to ICDRT, wait until TEND in ICSR is set to 1, with TDRE = 1. When TEND is set, clear TEND.
4. Clear TRS for the end processing, and read ICDRR (dummy read). SCL is free.
5. Clear TDRE.

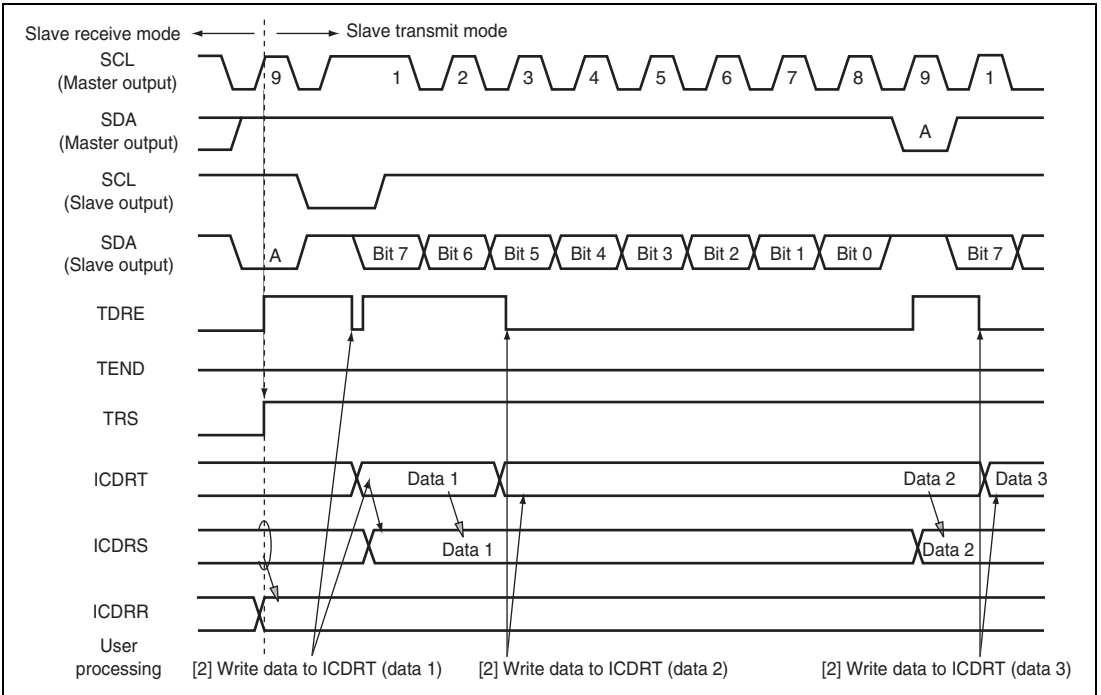

Figure 15.9 Slave Transmit Mode Operation Timing (1)

4. The last byte data is read by reading ICDRR.

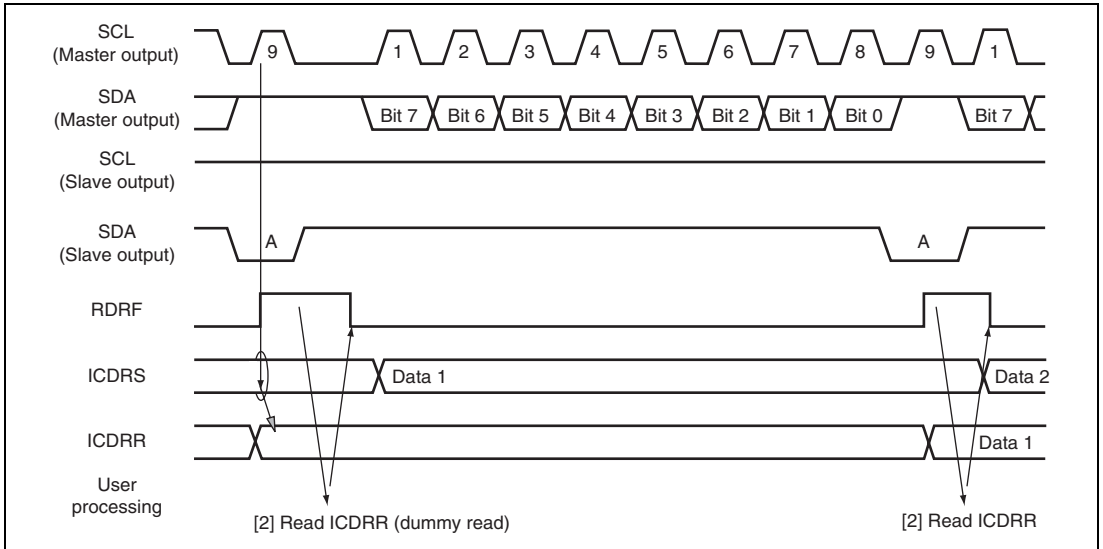

Figure 15.11 Slave Receive Mode Operation Timing (1)

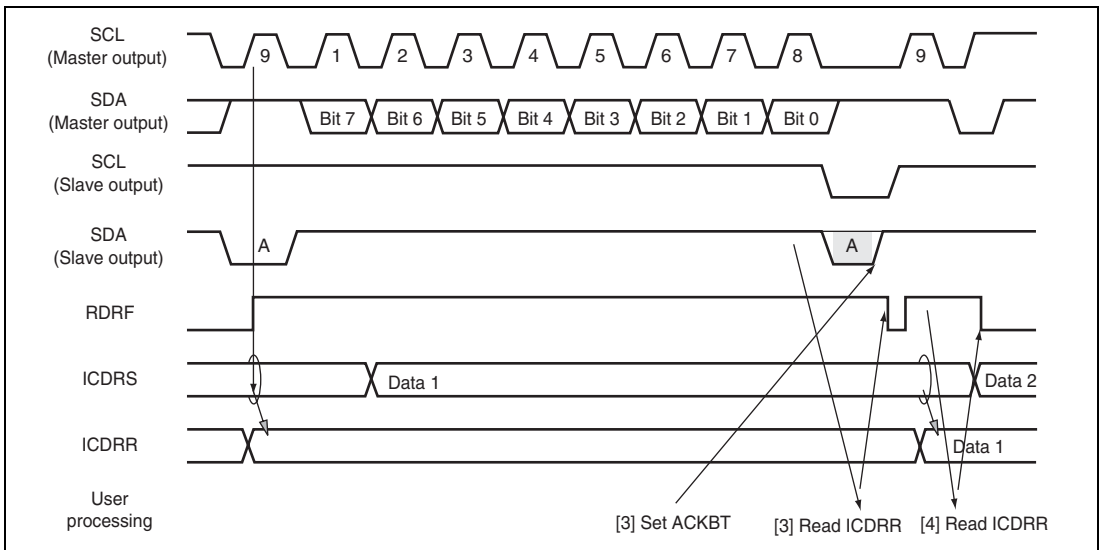

Figure 15.12 Slave Receive Mode Operation Timing (2)

15.4.6 Clocked Synchronous Serial Format

This module can be operated with the clocked synchronous serial format, by setting the FS bit in SAR to 1. When the MST bit in ICCR1 is 1, the transfer clock output from SCL is selected. When MST is 0, the external clock input is selected.

(1) Data Transfer Format:

Figure 15.13 shows the clocked synchronous serial transfer format.

The transfer data is output from the rise to the fall of the SCL clock, and the data at the rising edge of the SCL clock is guaranteed. The MLS bit in ICMR sets the order of data transfer, in either the MSB first or LSB first. The output level of SDA can be changed during the transfer wait, by the SDAO bit in ICCR2.

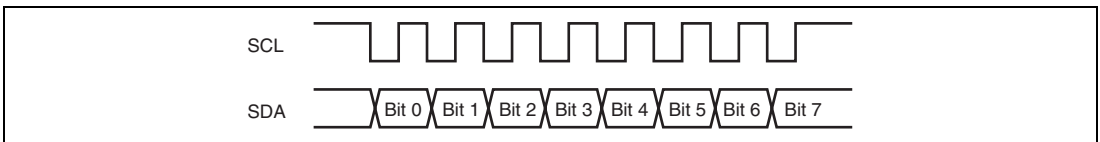

Figure 15.13 Clocked Synchronous Serial Transfer Format

(2) Transmit Operation:

In transmit mode, transmit data is output from SDA, in synchronization with the fall of the transfer clock. The transfer clock is output when MST in ICCR1 is 1, and is input when MST is 0. For transmit mode operation timing, refer to figure 15.14. The transmission procedure and operations in transmit mode are described below.

1. Set the ICE bit in ICCR1 to 1. Set the MST and CKS3 to CKS0 bits in ICCR1 to 1. (Initial setting)
2. Set the TRS bit in ICCR1 to select the transmit mode. Then, TDRE in ICSR is set.
3. Confirm that TDRE has been set. Then, write the transmit data to ICDRT. The data is transferred from ICDRT to ICDRS, and TDRE is set automatically. The continuous transmission is performed by writing data to ICDRT every time TDRE is set. When changing from transmit mode to receive mode, clear TRS while TDRE is 1.

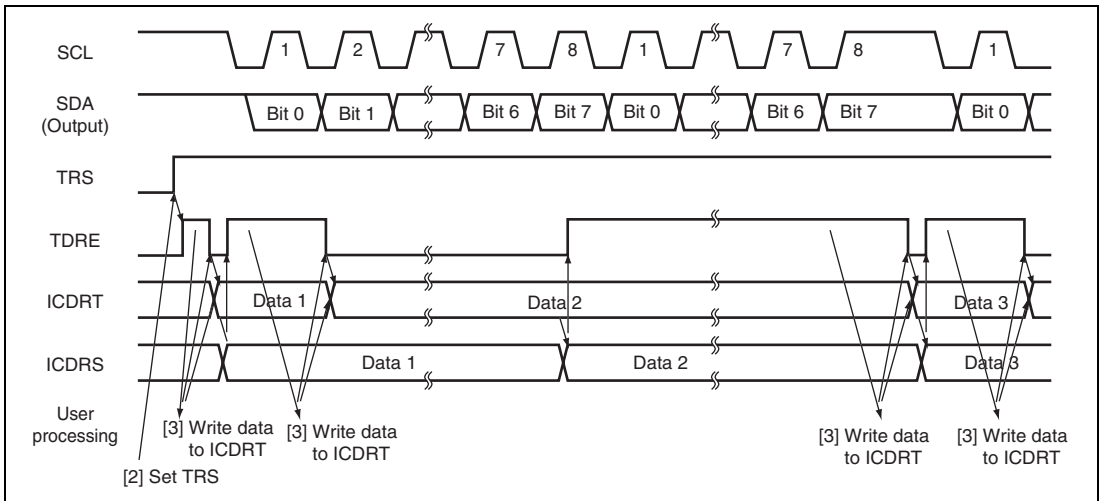

Figure 15.14 Transmit Mode Operation Timing

(3) Receive Operation:

In receive mode, data is latched at the rise of the transfer clock. The transfer clock is output when MST in ICCR1 is 1, and is input when MST is 0. For receive mode operation timing, refer to figure 15.15. The reception procedure and operations in receive mode are described below.

1. Set the ICE bit in ICCR1 to 1. Set the MST and CKS3 to CKS0 bits in ICCR1 to 1. (Initial setting)
2. When the transfer clock is output, set MST to 1 to start outputting the receive clock.
3. When the receive operation is completed, data is transferred from ICDRS to ICDRR and RDRF in ICSR is set. When MST = 1, the next byte can be received, so the clock is continually output. The continuous reception is performed by reading ICDRR every time RDRF is set. When the 8th clock is risen while RDRF is 1, the overrun is detected and AL/OVE in ICSR is set. At this time, the previous reception data is retained in ICDRR.
4. To stop receiving when MST = 1, set RCVD in ICCR1 to 1, then read ICDRR. Then, SCL is fixed high after receiving the next byte data.

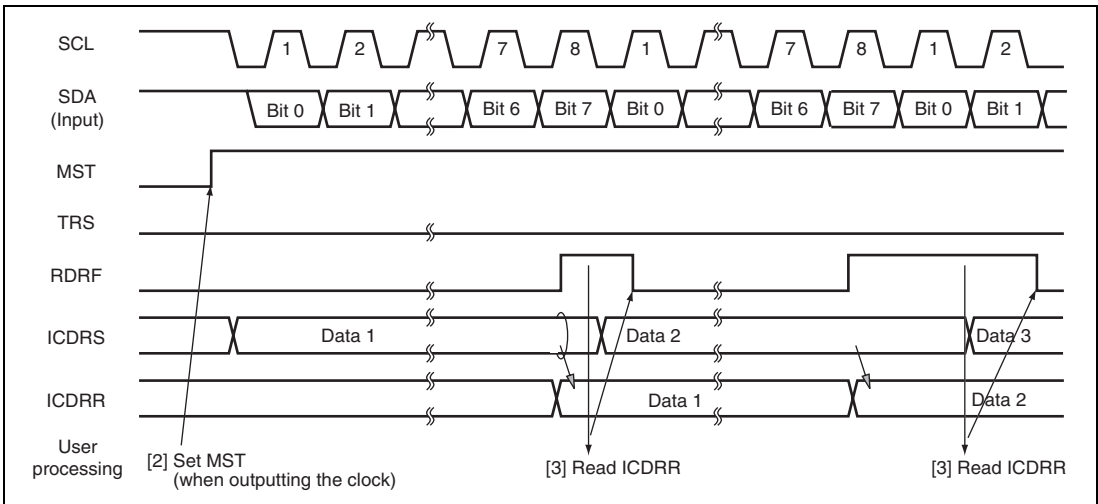

Figure 15.15 Receive Mode Operation Timing

15.4.7 Noise Canceler

The logic levels at the SCL and SDA pins are routed through the noise canceler before being latched internally. Figure 15.16 shows a block diagram of the noise canceler.

The noise canceler consists of two cascaded latches and a match detector. The SCL (or SDA) input signal is sampled on the system clock, but is not passed forward to the next circuit unless the outputs of both latches agree. If they do not agree, the previous value is held.

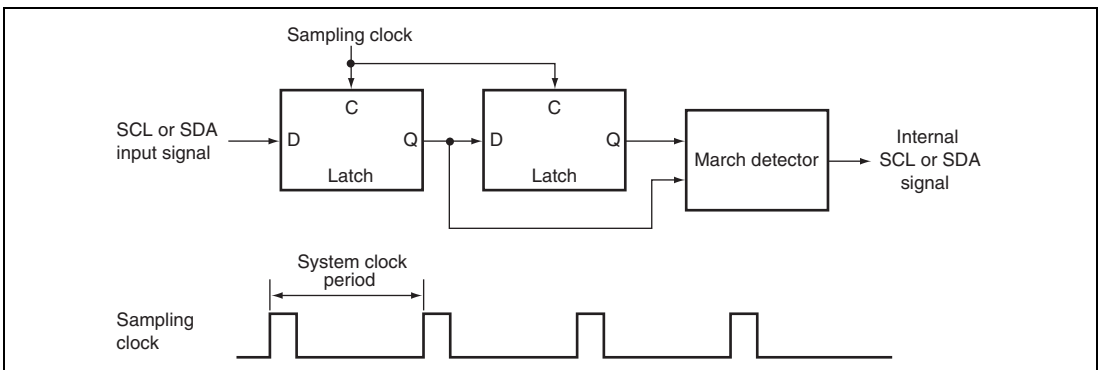

Figure 15.16 Block Diagram of Noise Canceler

15.4.8 Example of Use

Flowcharts in respective modes that use the I²C bus interface are shown in figures 15.17 to 15.20.

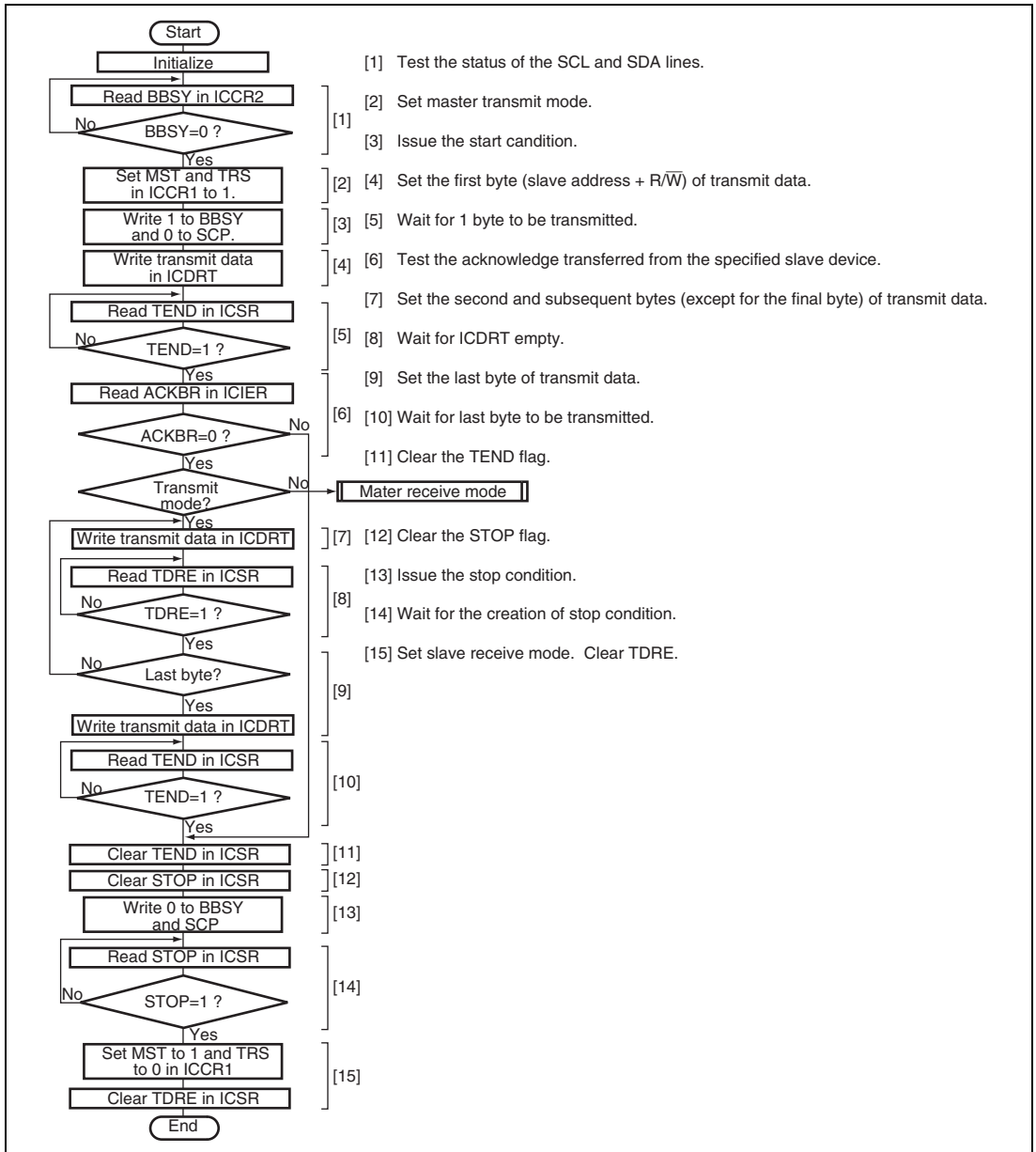

Figure 15.17 Sample Flowchart for Master Transmit Mode

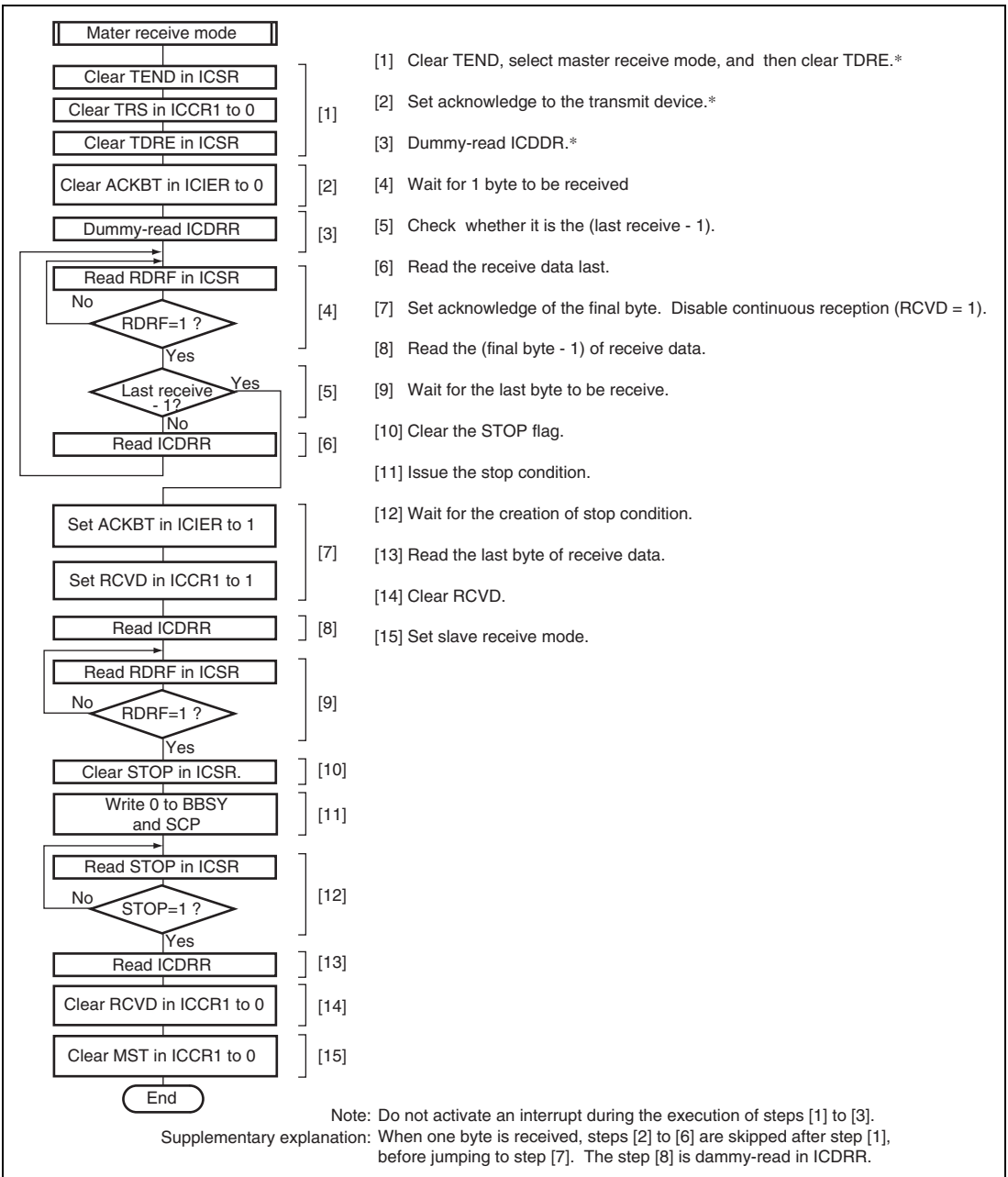

Figure 15.18 Sample Flowchart for Master Receive Mode

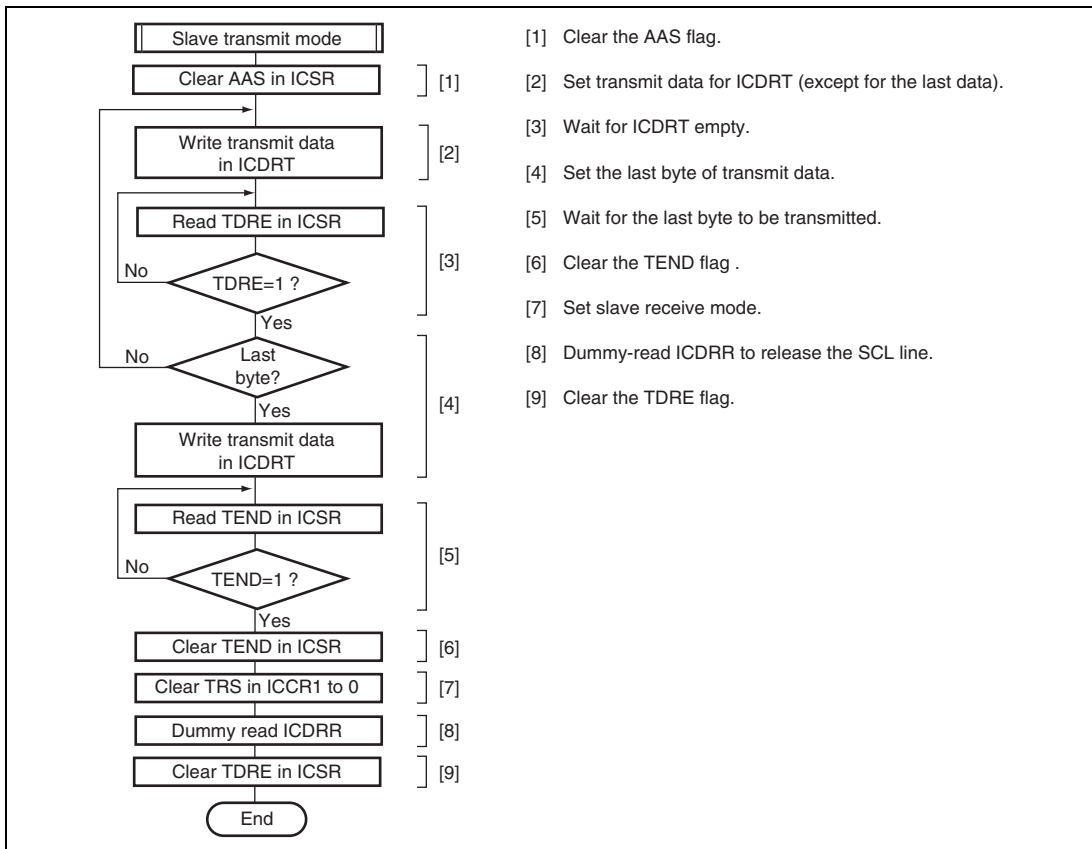
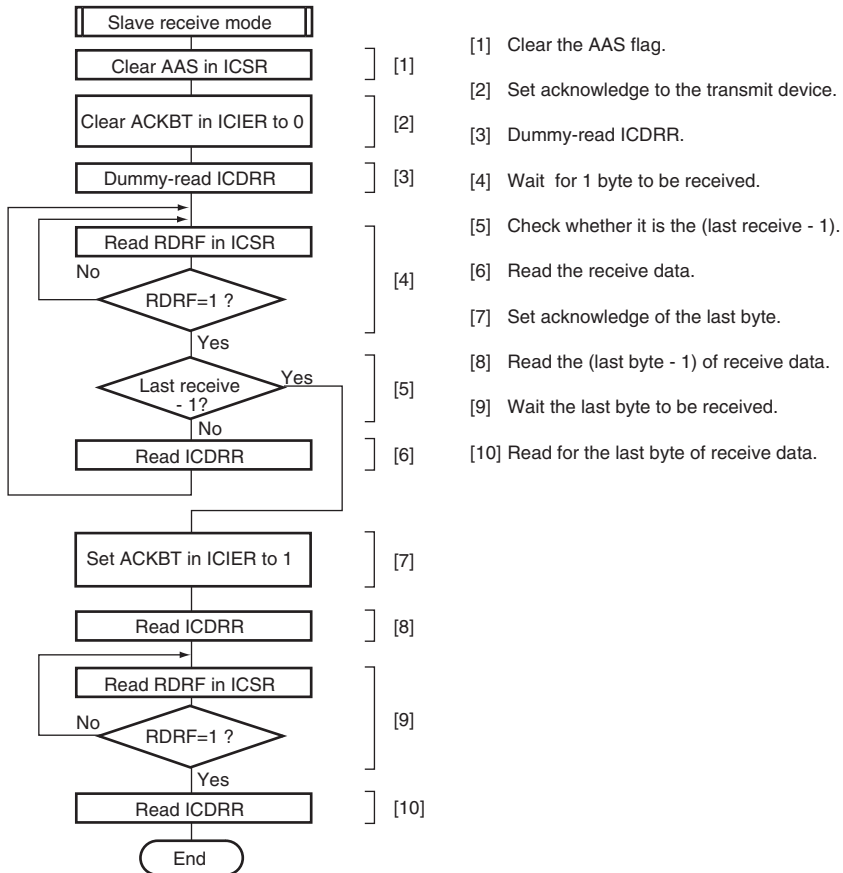

Figure 15.19 Sample Flowchart for Slave Transmit Mode



Supplementary explanation: When one byte is received, steps [2] to [6] are skipped after step [1], before jumping to step [7]. The step [8] is dummy-read in ICRRR.

Figure 15.20 Sample Flowchart for Slave Receive Mode

15.5 Interrupts

There are six interrupt requests in this module; transmit data empty, transmit end, receive data full, NACK receive, STOP recognition, and arbitration lost/overrun error. Table 15.3 shows the contents of each interrupt request.

Table 15.3 Interrupt Requests

Interrupt Request	Abbreviation	Interrupt Condition	I ² C Mode	Clocked Synchronous Mode
Transmit Data Empty	TXI	(TDRE=1) · (TIE=1)	○	○
Transmit End	TEI	(TEND=1) · (TEIE=1)	○	○
Receive Data Full	RXI	(RDRF=1) · (RIE=1)	○	○
STOP Recognition	STPI	(STOP=1) · (STIE=1)	○	×
NACK Receive	NAKI	{(NACKF=1)+(AL=1)} · (NAKIE=1)	○	×
Arbitration Lost/Overrun Error			○	○

When interrupt conditions described in table 15.3 are 1 and the I bit in CCR is 0, the CPU executes an interrupt exception processing. Interrupt sources should be cleared in the exception processing. TDRE and TEND are automatically cleared to 0 by writing the transmit data to ICDRT. RDRF are automatically cleared to 0 by reading ICDRR. TDRE is set to 1 again at the same time when transmit data is written to ICDRT. When TDRE is cleared to 0, then an excessive data of one byte may be transmitted.

15.6 Bit Synchronous Circuit

In master mode, this module has a possibility that high level period may be short in the two states described below.

- When SCL is driven to low by the slave device
- When the rising speed of SCL is lowered by the load of the SCL line (load capacitance or pull-up resistance)

Therefore, it monitors SCL and communicates by bit with synchronization.

Figure 15.21 shows the timing of the bit synchronous circuit and table 15.4 shows the time when SCL output changes from low to Hi-Z then SCL is monitored.

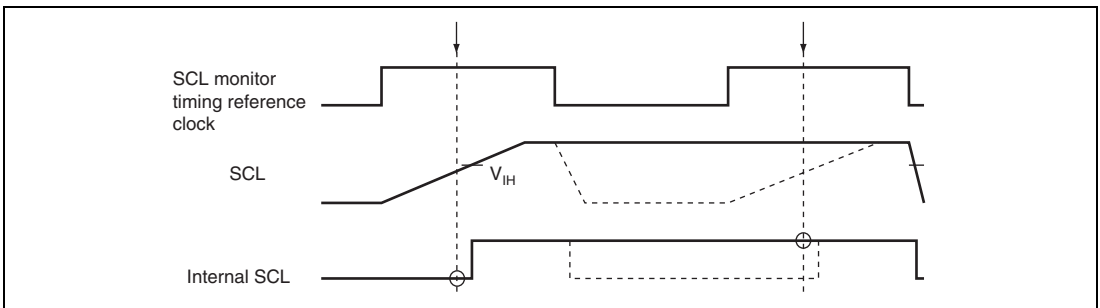

Figure 15.21 Timing of Bit Synchronous Circuit

Table 15.4 Time for Monitoring SCL

CKS3	CKS2	Time for Monitoring SCL
0	0	7.5 tcyc
	1	19.5 tcyc
1	0	17.5 tcyc
	1	41.5 tcyc

15.7 Usage Notes

15.7.1 Issue (Retransmission) of Start/Stop Conditions

In master mode, when the start/stop conditions are issued (retransmitted) at the specific timing under the following condition 1 or 2, such conditions may not be output successfully. To avoid this, issue (retransmit) the start/stop conditions after the fall of the ninth clock is confirmed. Check the SCLO bit in the I²C control register 2 (IICR2) to confirm the fall of the ninth clock.

1. When the rising of SCL falls behind the time specified in section 15.6, Bit Synchronous Circuit, by the load of the SCL bus (load capacitance or pull-up resistance)
2. When the bit synchronous circuit is activated by extending the low period of eighth and ninth clocks, that is driven by the slave device

15.7.2 WAIT Setting in I²C Bus Mode Register (ICMR)

If the WAIT bit is set to 1, and the SCL signal is driven low for two or more transfer clocks by the slave device at the eighth and ninth clocks, the high period of ninth clock may be shortened. To avoid this, set the WAIT bit in ICMR to 0.

Section 16 A/D Converter

This LSI includes a successive approximation type 10-bit A/D converter that allows up to four analog input channels to be selected. The block diagram of the A/D converter is shown in figure 16.1.

16.1 Features

- 10-bit resolution
- Four input channels
- Conversion time: At least 7 μ s per channel (at 10 MHz operation)
- Two operating modes
 - Single mode: Single-channel A/D conversion
 - Scan mode: Continuous A/D conversion on 1 to 4 channels
- Four data registers
 - Conversion results are held in a 16-bit data register for each channel
- Sample and hold function
- Two conversion start methods
 - Software
 - External trigger signal
- Interrupt request
 - An A/D conversion end interrupt request (ADI) can be generated

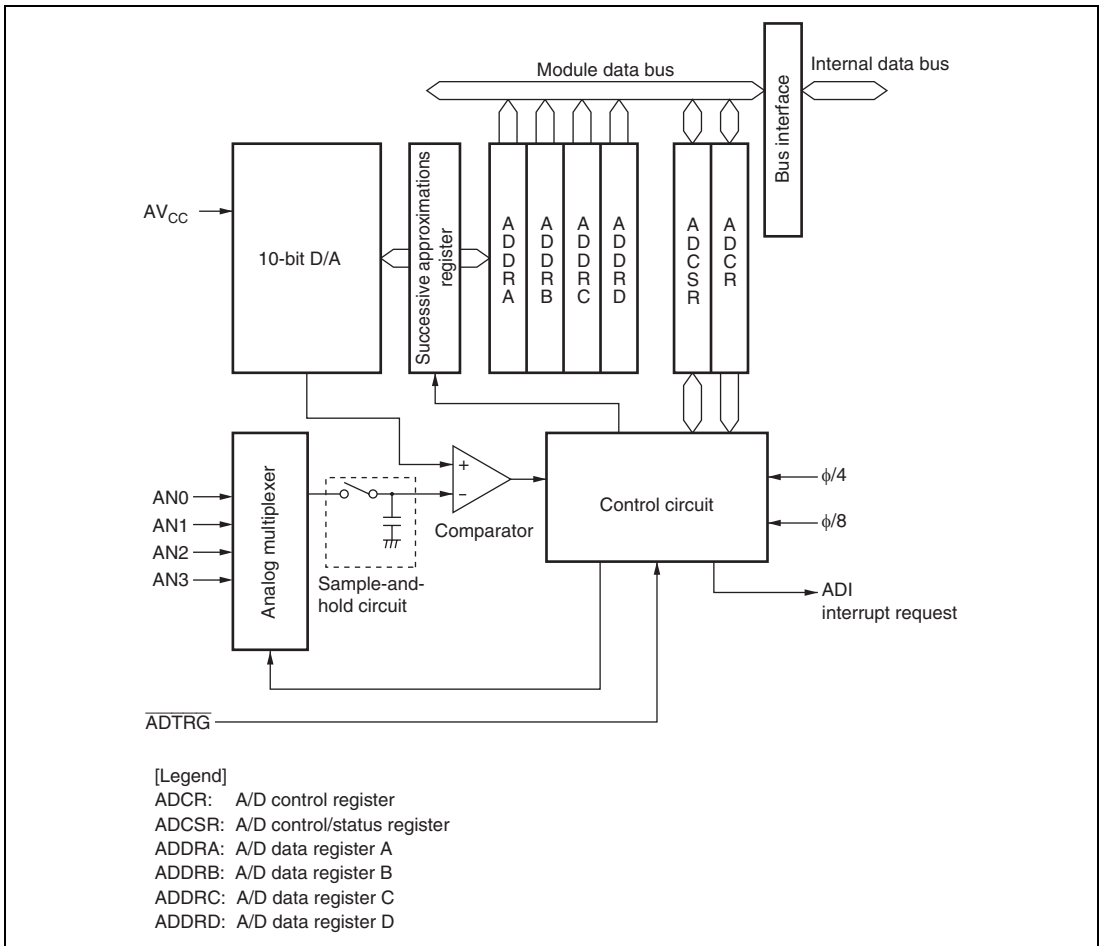

Figure 16.1 Block Diagram of A/D Converter

16.2 Input/Output Pins

Table 16.1 summarizes the input pins used by the A/D converter.

Table 16.1 Pin Configuration

Pin Name	Symbol	I/O	Function
Analog power supply pin	AV_{CC}	Input	Analog block power supply pin
Analog input pin 0	AN0	Input	Analog input pins
Analog input pin 1	AN1	Input	
Analog input pin 2	AN2	Input	
Analog input pin 3	AN3	Input	
A/D external trigger input pin	\overline{ADTRG}	Input	External trigger input pin for starting A/D conversion

16.3 Register Description

The A/D converter has the following registers.

- A/D data register A (ADDRA)
- A/D data register B (ADDRB)
- A/D data register C (ADDRC)
- A/D data register D (ADDRD)
- A/D control/status register (ADCSR)
- A/D control register (ADCR)

16.3.1 A/D Data Registers A to D (ADDRA to ADDRD)

There are four 16-bit read-only ADDR registers; ADDRA to ADDRD, used to store the results of A/D conversion. The ADDR registers, which store a conversion result for each channel, are shown in table 16.2.

The converted 10-bit data is stored in bits 6 to 15. The lower 6 bits are always read as 0.

The data bus between the CPU and the A/D converter is 8 bits wide. The upper byte can be read directly from the CPU, however the lower byte should be read via a temporary register. The temporary register contents are transferred from the ADDR when the upper byte data is read.

Therefore, byte access to ADDR should be done by reading the upper byte first then the lower one. ADDR is initialized to H'0000.

Table 16.2 Analog Input Channels and Corresponding ADDR Registers

Analog Input Channel	A/D Data Register to Be Stored Results of A/D Conversion
AN0	ADDRA
AN1	ADDRB
AN2	ADDRC
AN3	ADDRD

16.3.2 A/D Control/Status Register (ADCSR)

ADCSR consists of the control bits and conversion end status bits of the A/D converter.

Bit	Bit Name	Initial Value	R/W	Description
7	ADF	0	R/W	<p>A/D End Flag</p> <p>[Setting conditions]</p> <ul style="list-style-type: none"> When A/D conversion ends in single mode When A/D conversion ends on all the channels selected in scan mode <p>[Clearing condition]</p> <ul style="list-style-type: none"> When 0 is written after reading ADF = 1
6	ADIE	0	R/W	<p>A/D Interrupt Enable</p> <p>A/D conversion end interrupt (ADI) request enabled by ADF when 1 is set</p>
5	ADST	0	R/W	<p>A/D Start</p> <p>Setting this bit to 1 starts A/D conversion. In single mode, this bit is cleared to 0 automatically when conversion on the specified channel is complete. In scan mode, conversion continues sequentially on the specified channels until this bit is cleared to 0 by software, a reset, or a transition to standby mode.</p>

Bit	Bit Name	Initial Value	R/W	Description
4	SCAN	0	R/W	<p>Scan Mode</p> <p>Selects single mode or scan mode as the A/D conversion operating mode.</p> <p>0: Single mode</p> <p>1: Scan mode</p>
3	CKS	0	R/W	<p>Clock Select</p> <p>Selects the A/D conversions time</p> <p>0: Conversion time = 134 states (max.)</p> <p>1: Conversion time = 70 states (max.)</p> <p>Clear the ADST bit to 0 before switching the conversion time.</p>
2	CH2	0	R/W	Channel Select 0 to 2
1	CH1	0	R/W	Select analog input channels.
0	CH0	0	R/W	<p>When SCAN = 0 When SCAN = 1</p> <p>000: AN0 000: AN0</p> <p>001: AN1 001: AN0 to AN1</p> <p>010: AN2 010: AN0 to AN2</p> <p>011: AN3 011: AN0 to AN3</p> <p>Note: When executing the A/D conversion through AN3 or AN2, do not set the VDDII bit in LVDCR to 0. If 0 is set, the A/D conversion accuracy is not guaranteed.</p>

16.3.3 A/D Control Register (ADCR)

ADCR enables A/D conversion started by an external trigger signal.

Bit	Bit Name	Initial Value	R/W	Description
7	TRGE	0	R/W	<p>Trigger Enable</p> <p>A/D conversion is started at the falling edge and the rising edge of the external trigger signal (ADTRG) when this bit is set to 1.</p> <p>The selection between the falling edge and rising edge of the external trigger pin (ADTRG) conforms to the WPEG5 bit in the interrupt edge select register 2 (IEGR2)</p>
6 to 4	—	All 1	—	<p>Reserved</p> <p>These bits are always read as 1.</p>
3, 2	—	All 0	R/W	<p>Reserved</p> <p>Although these bits are readable/writable, they should not be set to 1.</p>
1	—	1	R/W	<p>Reserved</p> <p>This bit is always read as 1.</p>
0	—	0	R/W	<p>Reserved</p> <p>Although this bit is readable/writable, it should not be set to 1.</p>

16.4 Operation

The A/D converter operates by successive approximation with 10-bit resolution. It has two operating modes; single mode and scan mode. When changing the operating mode or analog input channel, in order to prevent incorrect operation, first clear the bit ADST to 0 in ADCSR. The ADST bit can be set at the same time as the operating mode or analog input channel is changed.

16.4.1 Single Mode

In single mode, A/D conversion is performed once for the analog input on the specified single channel as follows:

1. A/D conversion is started from the first channel when the ADST bit in ADCSR is set to 1, according to software or external trigger input.
2. When A/D conversion is completed, the result is transferred to the corresponding A/D data register to the channel.
3. On completion of conversion, the ADF bit in ADCSR is set to 1. If the ADIE bit is set to 1 at this time, an ADI interrupt request is generated.
4. The ADST bit remains set to 1 during A/D conversion. When A/D conversion ends, the ADST bit is automatically cleared to 0 and the A/D converter enters the wait state.

16.4.2 Scan Mode

In scan mode, A/D conversion is performed sequentially for the analog input on the specified channels (four channels maximum) as follows:

1. When the ADST bit is set to 1 by software, or external trigger input, A/D conversion starts on the first channel in the group.
2. When A/D conversion for each channel is completed, the result is sequentially transferred to the A/D data register corresponding to each channel.
3. When conversion of all the selected channels is completed, the ADF flag in ADCSR is set to 1. If the ADIE bit is set to 1 at this time, an ADI interrupt is requested. Conversion of the first channel in the group starts again.
4. The ADST bit is not automatically cleared to 0. Steps [2] to [3] are repeated as long as the ADST bit remains set to 1. When the ADST bit is cleared to 0, A/D conversion stops.

16.4.3 Input Sampling and A/D Conversion Time

The A/D converter has a built-in sample-and-hold circuit. The A/D converter samples the analog input when the A/D conversion start delay time (t_D) has passed after the ADST bit is set to 1, then starts conversion. Figure 16.2 shows the A/D conversion timing. Table 16.3 shows the A/D conversion time.

As indicated in figure 16.2, the A/D conversion time includes t_D and the input sampling time. The length of t_D varies depending on the timing of the write access to ADCSR. The total conversion time therefore varies within the ranges indicated in table 16.3.

In scan mode, the values given in table 16.3 apply to the first conversion time. In the second and subsequent conversions, the conversion time is 128 states (fixed) when $CKS = 0$ and 66 states (fixed) when $CKS = 1$.

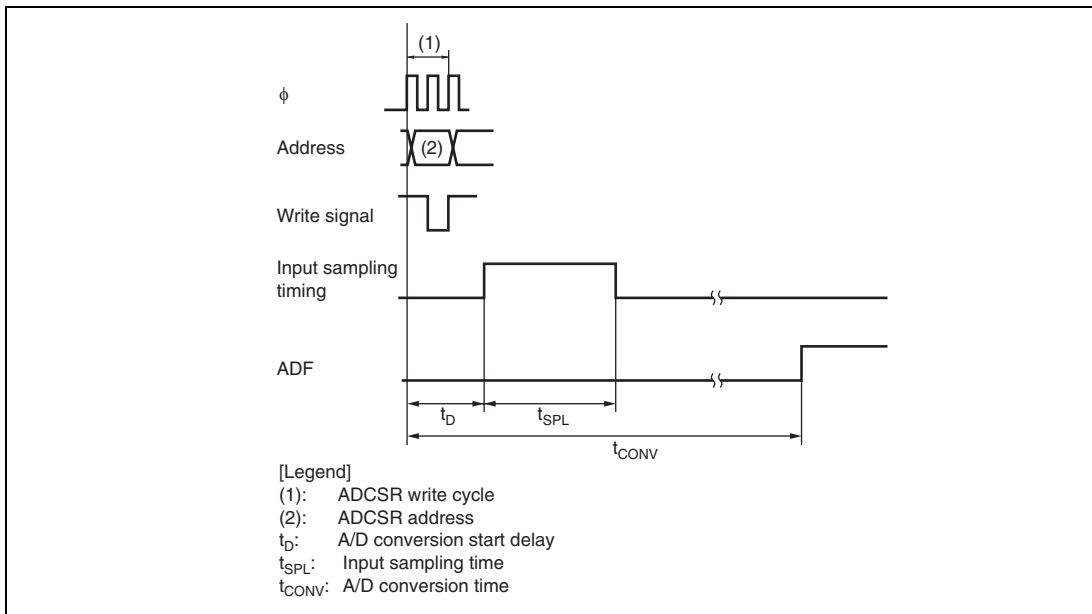

Figure 16.2 A/D Conversion Timing

Table 16.3 A/D Conversion Time (Single Mode)

Item	Symbol	CKS = 0			CKS = 1		
		Min.	Typ.	Max.	Min.	Typ.	Max.
A/D conversion start delay	t_d	6	—	9	4	—	5
Input sampling time	t_{SPL}	—	31	—	—	15	—
A/D conversion time	t_{CONV}	131	—	134	69	—	70

Note: All values represent the number of states.

16.4.4 External Trigger Input Timing

A/D conversion can also be started by an external trigger input. When the TRGE bit is set to 1 in ADCR, external trigger input is enabled at the \overline{ADTRG} pin. A falling edge at the \overline{ADTRG} input pin sets the ADST bit to 1 in ADCSR, starting A/D conversion. Other operations, in both single and scan modes, are the same as when the bit ADST has been set to 1 by software. Figure 16.3 shows the timing.

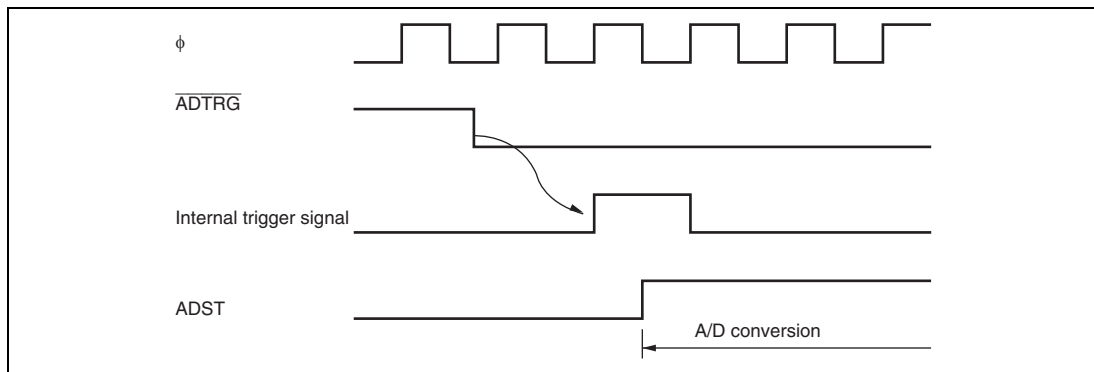
**Figure 16.3 External Trigger Input Timing**

16.5 A/D Conversion Accuracy Definitions

This LSI's A/D conversion accuracy definitions are given below.

- Resolution
The number of A/D converter digital output codes
- Quantization error
The deviation inherent in the A/D converter, given by 1/2 LSB (see figure 16.4).
- Offset error
The deviation of the analog input voltage value from the ideal A/D conversion characteristic when the digital output changes from the minimum voltage value 000000000 to 0000000001 (see figure 16.5).
- Full-scale error
The deviation of the analog input voltage value from the ideal A/D conversion characteristic when the digital output changes from 111111110 to 111111111 (see figure 16.5).
- Nonlinearity error
The error with respect to the ideal A/D conversion characteristics between zero voltage and full-scale voltage. Does not include offset error, full-scale error, or quantization error.
- Absolute accuracy
The deviation between the digital value and the analog input value. Includes offset error, full-scale error, quantization error, and nonlinearity error.

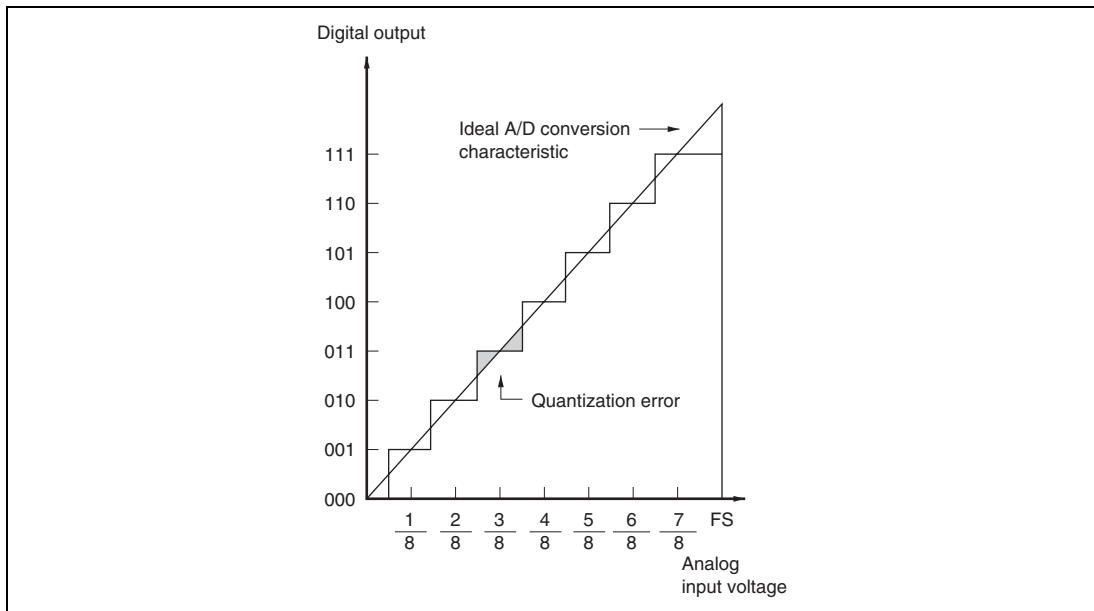

Figure 16.4 A/D Conversion Accuracy Definitions (1)

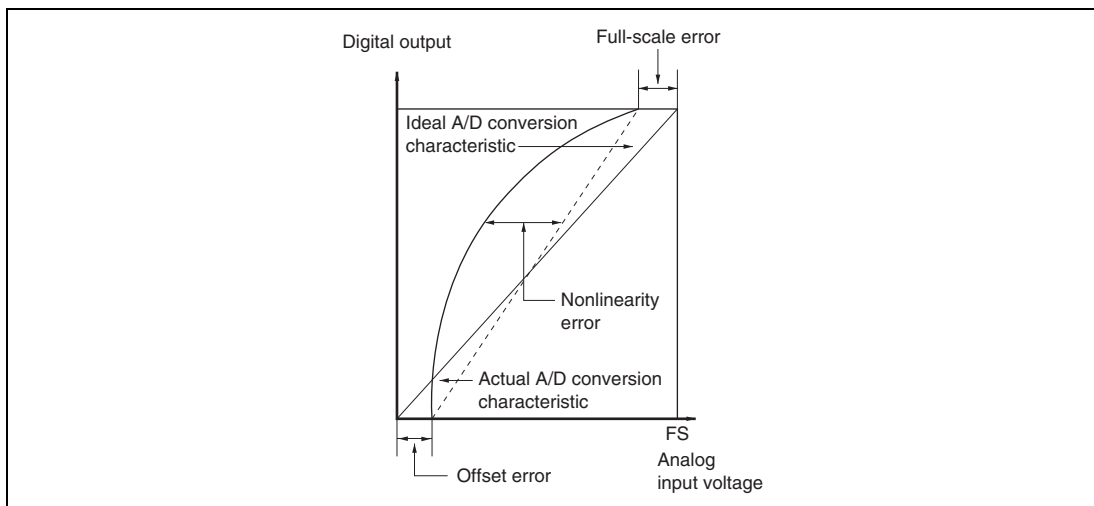

Figure 16.5 A/D Conversion Accuracy Definitions (2)

16.6 Usage Notes

16.6.1 Permissible Signal Source Impedance

This LSI's analog input is designed such that conversion accuracy is guaranteed for an input signal for which the signal source impedance is $5\text{ k}\Omega$ or less. This specification is provided to enable the A/D converter's sample-and-hold circuit input capacitance to be charged within the sampling time; if the sensor output impedance exceeds $5\text{ k}\Omega$, charging may be insufficient and it may not be possible to guarantee A/D conversion accuracy. However, for A/D conversion in single mode with a large capacitance provided externally, the input load will essentially comprise only the internal input resistance of $10\text{ k}\Omega$, and the signal source impedance is ignored. However, as a low-pass filter effect is obtained in this case, it may not be possible to follow an analog signal with a large differential coefficient (e.g., $5\text{ mV}/\mu\text{s}$ or greater) (see figure 16.6). When converting a high-speed analog signal or converting in scan mode, a low-impedance buffer should be inserted.

16.6.2 Influences on Absolute Accuracy

Adding capacitance results in coupling with GND, and therefore noise in GND may adversely affect absolute accuracy. Be sure to make the connection to an electrically stable GND.

Care is also required to ensure that filter circuits do not interfere with digital signals or act as antennas on the mounting board.

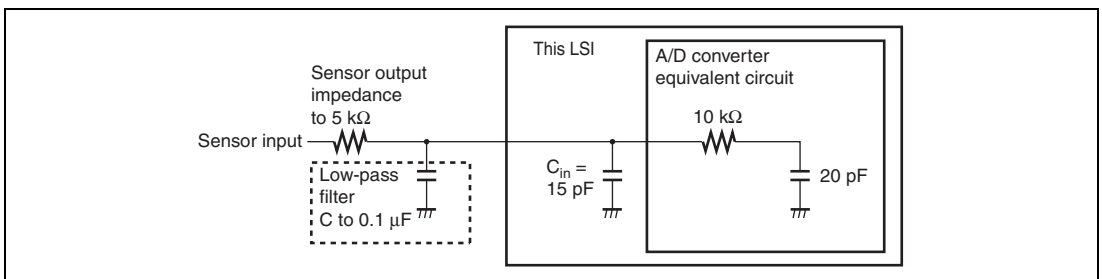

Figure 16.6 Analog Input Circuit Example

Section 17 Band-Gap Circuit, Power-On Reset, and Low-Voltage Detection Circuits

This LSI can include a band-gap circuit (BGR, band-gap regulator), a power-on reset circuit and low-voltage detection circuit.

BGR supplies a reference voltage to the on-chip oscillator and low-voltage detection circuit. Figure 17.1 shows the block diagram of how BGR is allocated.

The low-voltage detection (LVD) circuit consists of two circuits: LVDI (interrupt by low voltage detection) and LVDR (reset by low voltage detection) circuits.

This circuit is used to prevent abnormal operation (program runaway) from occurring due to the power supply voltage fall and to recreate the state before the power supply voltage fall when the power supply voltage rises again.

Even if the power supply voltage falls, the unstable state when the power supply voltage falls below the guaranteed operating voltage can be removed by entering standby mode when exceeding the guaranteed operating voltage and during normal operation. Thus, system stability can be improved. If the power supply voltage falls more, the reset state is automatically entered. If the power supply voltage rises again, the reset state is held for a specified period, then active mode is automatically entered.

Figure 17.2 is a block diagram of the power-on reset circuit and the low-voltage detection circuit.

17.1 Features

- BGR circuit
Supplies stable reference voltage covering the entire operating voltage range and the operating temperature range.
Reduces power consumption when BGR is disabled by setting registers.
- Power-on reset circuit
Uses an external capacitor to generate an internal reset signal when power is first supplied.
- Low-voltage detection circuit
LVDR: Monitors the power-supply voltage, and generates an internal reset signal when the voltage falls below a given value.
LVDI: Monitors the power-supply voltage, and generates an interrupt when the voltage falls below or rises above respective given values.
Two detection levels for reset generation voltage are available: when only the LVDR circuit is used, or when the LVDI and LVDR circuits are both used.

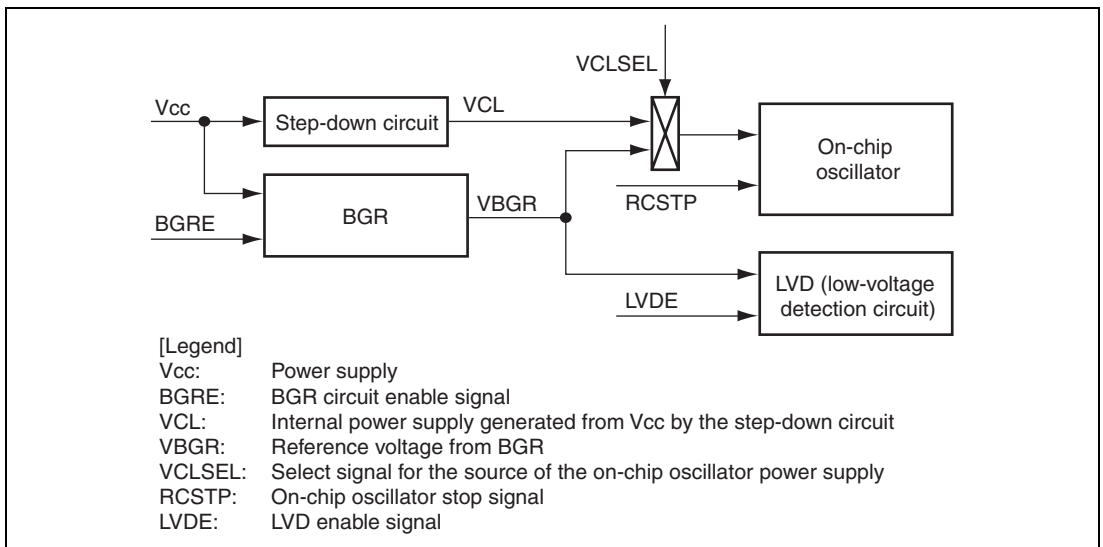

Figure 17.1 Block Diagram around BGR

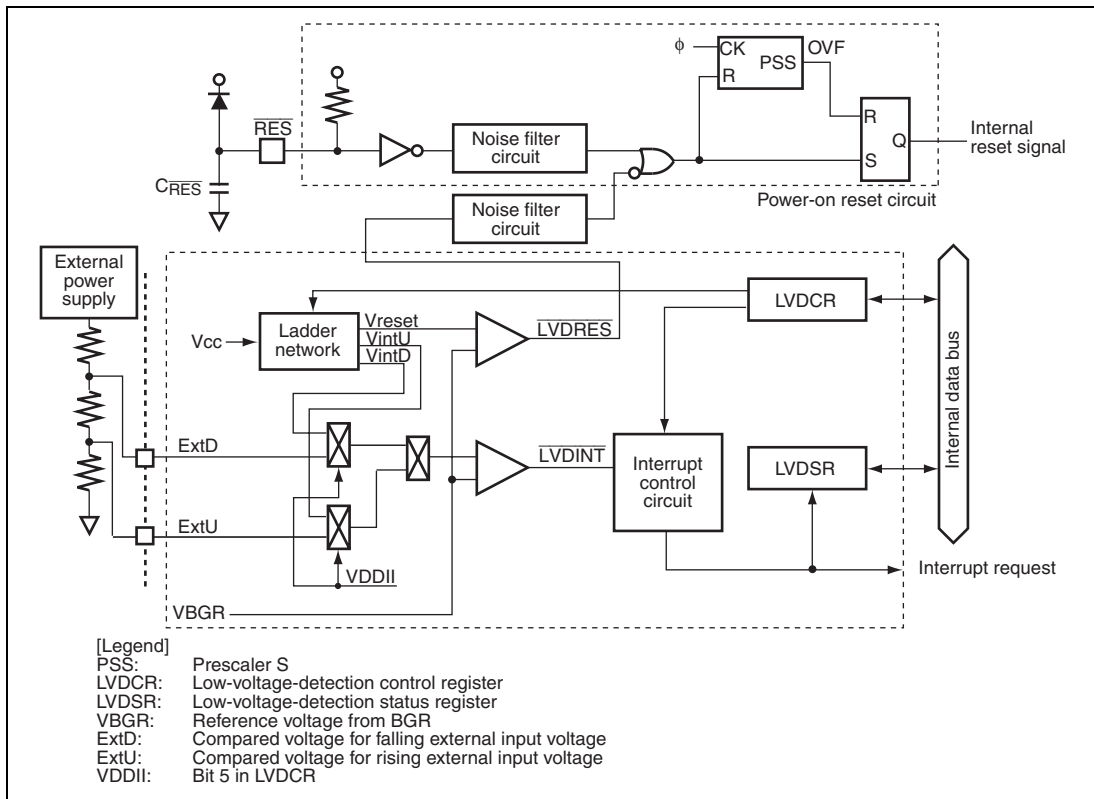

Figure 17.2 Block Diagram of Power-On Reset Circuit and Low-Voltage Detection Circuit

17.2 Register Descriptions

The low-voltage detection circuit has the following registers.

- Low-voltage-detection control register (LVDCR)
- Low-voltage-detection status register (LVDSR)

17.2.1 Low-Voltage-Detection Control Register (LVDCR)

LVDCR enables or disables the low-voltage detection circuit and BGR circuit, selects the compared voltage of the LVDI circuit, sets the detection levels for the LVDR circuit, enables or disables the LVDR circuit, and enables or disables generation of an interrupt when the power-supply voltage rises above or falls below the respective levels.

Table 17.1 shows the relationship between the LVDCR settings and functions to be selected. LVDCR should be set according to table 17.1.

Bit	Bit Name	Initial Value	R/W	Description
7	LVDE	1*	R/W	LVD Enable 0: Low-voltage detection circuit is not used (standby mode) 1: Low-voltage detection circuit is used
6	BGRE	1*	R/W	BGR Enable 0: BGR circuit is not used (standby mode) 1: BGR circuit is used
5	VDDII	1*	R/W	LVDR External Compared Voltage Input Inhibit 0: Use external voltage as LVDI compared voltage 1: Use internal voltage as LVDI compared voltage
4	—	1	—	Reserved This bit is always read as 1 and cannot be modified.

Bit	Bit Name	Initial Value	R/W	Description
3	LVDSSEL	0*	R/W	LVDR Detection Level Select 0: Reset detection voltage is 2.3 V (Typ.) 1: Reset detection voltage is 3.6 V (Typ.) When the falling or rising voltage detection interrupt is used, the reset detection voltage of 2.3 V (Typ.) should be used. When only a reset detection interrupt is used, reset detection voltage of 3.6 V (Typ.) should be used.
2	LVDRE	1*	R/W	LVDR Enable 0: Disables an LVDR 1: Enables an LVDR
1	LVDDE	0	R/W	Voltage-Fall-Interrupt Enable 0: Interrupt on the power-supply voltage falling disabled 1: Interrupt on the power-supply voltage falling enabled
0	LVDUE	0	R/W	Voltage-Rise-Interrupt Enable 0: Interrupt on the power-supply voltage rising disabled 1: Interrupt on the power-supply voltage rising enabled

Note: * Not initialized by an LVDR but initialized by a power-on reset or a watchdog timer reset.

Table 17.1 LVDCR Settings and Select Functions

LVDCR Settings							Select Functions			
LVDE	BGRE	VDDII	LVDSSEL	LVDRE	LVDDE	LVDUE	Power-On Reset	LVDR	Low-Voltage-Detection Fall Interrupt	Low-Voltage-Detection Rise Interrupt
0	* ¹	* ²	* ²	* ²	* ²	* ²	√	—	—	—
1	1	* ¹	1	1	0	0	√	√	—	—
1	1	* ¹	0	0	1	0	√	—	√	—
1	1	* ¹	0	0	1	1	√	—	√	√
1	1	* ¹	0	1	1	1	√	√	√	√

Notes: 1. Set these bits if necessary.
2. Settings are ignored.

17.2.2 Low-Voltage-Detection Status Register (LVDSR)

LVDSR indicates whether the power-supply voltage falls below or rises above the respective given values.

Bit	Bit Name	Initial Value	R/W	Description
7 to 2	—	All 1	—	Reserved These bits are always read as 1 and cannot be modified.
1	LVDDF	0*	R/W	LVD Power-Supply Voltage Fall Flag [Setting condition] <ul style="list-style-type: none"> When the power-supply voltage falls below $V_{int}(D)$ (Typ. = 3.7 V) [Clearing condition] <ul style="list-style-type: none"> When writing 0 to this bit after reading it as 1
0	LVDFUF	0*	R/W	LVD Power-Supply Voltage Rise Flag [Setting condition] <ul style="list-style-type: none"> When the power supply voltage falls below $V_{int}(D)$ while the LVDUE bit in LVDCR is set to 1 and then rises above $V_{int}(U)$ (Typ. = 4.0 V) before falling below V_{reset1} (Typ. = 2.3 V) [Clearing condition] <ul style="list-style-type: none"> When writing 0 to this bit after reading it as 1

Note: * Initialized by an LVDR.

17.3 Operations

17.3.1 Power-On Reset Circuit

Figure 17.3 shows the timing of the operation of the power-on reset circuit. As the power-supply voltage rises, the capacitor which is externally connected to the $\overline{\text{RES}}$ pin is gradually charged via the internal pull-up resistor (Typ. 150 k Ω). While the $\overline{\text{RES}}$ signal is driven low, the prescaler S and the entire chip retains the reset state. When the level on the $\overline{\text{RES}}$ signal reaches the specified value, the prescaler S is released from its reset state and it starts counting. The OVF signal is generated to release the internal reset signal after the prescaler S has counted 131,072 cycles of the ϕ clock. The noise filter circuit which removes noise with less than 400 ns (Typ.) is included to prevent the incorrect operation of this LSI caused by noise on the $\overline{\text{RES}}$ signal.

To achieve stable operation of this LSI, the power supply needs to rise to its full level and settle within the specified time. The maximum time required for the power supply to rise and settle (t_{PWON}) is determined by the oscillation frequency (f_{OSC}) and capacitance which is connected to $\overline{\text{RES}}$ pin ($C_{\overline{\text{RES}}}$). Where t_{PWON} is assumed to be the time required to reach 90 % of the full level of the power supply, the power supply circuit should be designed to satisfy the following formula.

$$t_{\text{PWON}} (\text{ms}) \leq 90 \times C_{\overline{\text{RES}}} (\mu\text{F}) + 162/f_{\text{OSC}} (\text{MHz})$$

$$(t_{\text{PWON}} \leq 3000 \text{ ms}, C_{\overline{\text{RES}}} \geq 0.22 \mu\text{F}, \text{ and } f_{\text{OSC}} = 10 \text{ in 2-MHz to 10-MHz operation})$$

Note that the power supply voltage (V_{CC}) must fall below $V_{\text{por}} = 100 \text{ mV}$ to remove charge on the $\overline{\text{RES}}$ pin. After that, it can be risen. To remove charge on the $\overline{\text{RES}}$ pin, it is recommended that the diode should be placed to V_{CC} . If the power supply voltage (V_{CC}) rises from the point above V_{por} , a power-on reset may not occur.

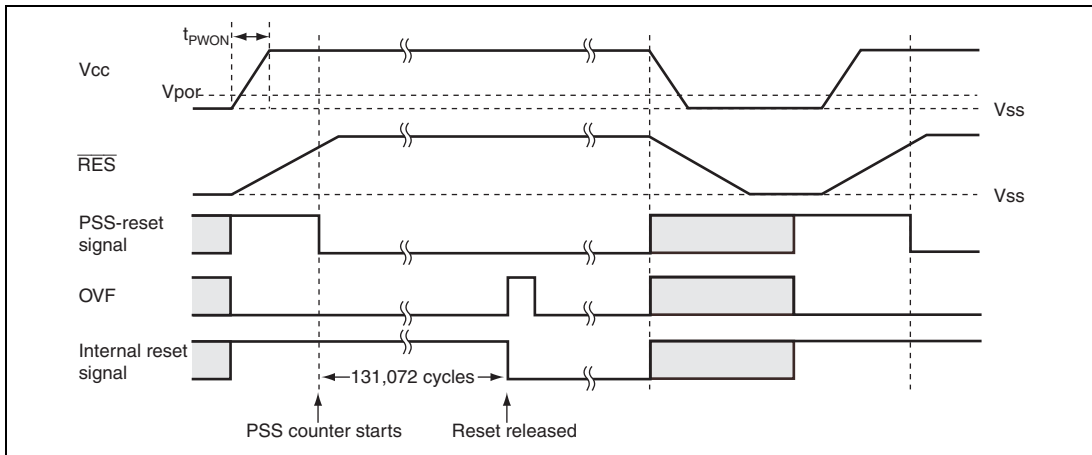

Figure 17.3 Operational Timing of Power-On Reset Circuit

17.3.2 Low-Voltage Detection Circuit

(1) LVDR (Reset by Low Voltage Detection) Circuit

Figure 17.4 shows the timing of the operation of the LVDR circuit. The LVDR circuit is enabled after a power-on reset is released. To cancel the LVDR circuit, first the LVDRE bit in LVDCR should be cleared to 0 and then the LVDE bit in LVDCR and, if necessary, the BGRE bit should be cleared to 0. The LVDE and the BGRE bits must not be cleared to 0 simultaneously with the LVDRE bit because incorrect operation may occur. To restart the LVDR circuit, set the LVDE bit and the BGRE bit to 1, wait for $50\ \mu\text{s}$ (t_{LVDRON}) given by a software timer until the reference voltage and the low-voltage-detection power supply have settled, then set the LVDRE bit to 1. After that, the output settings of ports must be made.

When the power-supply voltage falls below the V_{reset} voltage (2.3 V or 3.6 V (Typ.)), the LVDR circuit clears the $\overline{\text{LVDRES}}$ signal to 0, and resets prescaler S. The low-voltage detection reset state remains in place until a power-on reset is generated. When the power-supply voltage rises above the V_{reset} voltage again, prescaler S starts counting. It counts 131,072 clock (ϕ) cycles, and then releases the internal reset signal. In this case, the LVDE, BGRE, VDDII, LVDSEL, and LVDRE bits in LVDCR are not initialized.

Note that if the power supply voltage (V_{cc}) falls below $V_{\text{LVDRmin}} = 1.0\ \text{V}$ and then rises from that point, the low-voltage detection reset may not occur.

If the power supply voltage (V_{cc}) falls below $V_{\text{por}} = 100\ \text{mV}$, a power-on reset occurs.

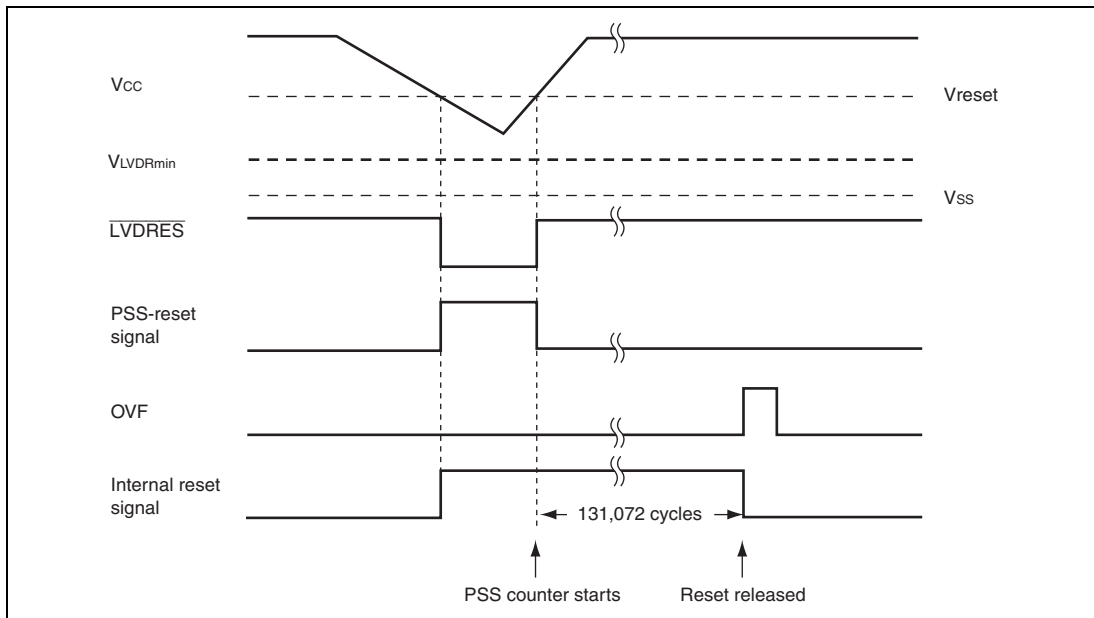

Figure 17.4 Operating Timing of LVDR Circuit

(2) Low Voltage Detection Interrupt (LVDI) Circuit (When Internally Generated Voltage is used for Detection)

Figure 17.5 shows the timing of the operation of the LVDI circuit.

The LVDI circuit is enabled after a power-on reset, however, the interrupt request is disabled. To enable the LVDI, the LVDDF bit and LVDUF bit in LVDSR must be cleared to 0 and then the LVDDE bit or LVDUE bit in LVDCR must be set to 1. After that, the output settings of ports must be made.

To cancel the LVDI, follow the procedures written in section 17.3.2 (4), Operating Procedures for Enabling/Disabling LVDR and LVDI Circuits.

To restart the LVDI circuit after standby mode, set the LVDE bit to 1, write 1 to VDDII (if necessary), and wait for $50\ \mu\text{s}$ (t_{LVDON}) given by a software timer until the reference voltage and the low-voltage detection power supply have settled. Then, clear the LVDDF and LVDUF bits to 0 and set the LVDDE or the LVDUE bit to 1. After that, the output settings of ports must be made.

When the power-supply voltage falls below $V_{\text{int}}(D)$ (Typ. = 3.7 V) voltage, the LVDI circuit clears the $\overline{\text{LVDINT}}$ signal to 0 and sets the LVDDF bit to 1. If the LVDDE bit is 1 at this time, an IRQ0 interrupt request is generated. In this case, the necessary data must be saved in the external

EEPROM and a transition to standby mode or subsleep mode must be made. Until this processing is completed, the power supply voltage must be higher than the lower limit of the guaranteed operating voltage.

When the power-supply voltage does not fall below the V_{reset1} (Typ. = 2.3 V) voltage and rises above the $V_{int(U)}$ (Typ. = 4.0 V) voltage, the LVDI circuit sets the \overline{LVDINT} signal to 1. If the LVDUE bit is 1 at this time, the LVDUF bit in LVDSR is set to 1 and an IRQ0 interrupt request is simultaneously generated.

If the power supply voltage (V_{cc}) falls below the V_{reset1} (Typ. = 2.3 V) voltage, this LSI enters low voltage detection reset operation (when LVDRE = 1).

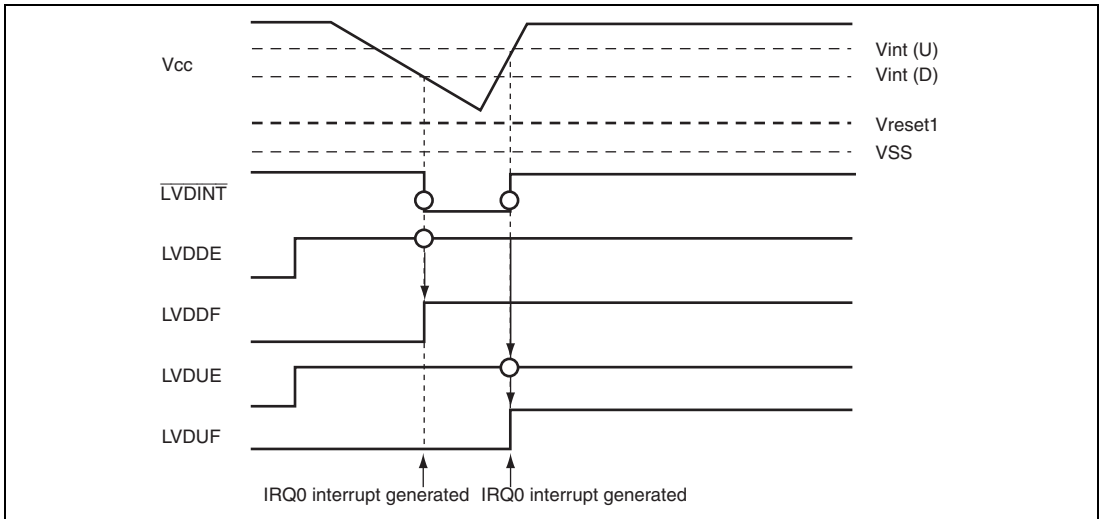

Figure 17.5 Operational Timing of LVDI Circuit

(3) Low Voltage Detection Interrupt (LVDI) Circuit (When Voltages Input via ExtU and ExtD Pins are used for Detection)

Figure 17.6 shows the timing of the LVDI circuit. The LVDI circuit is enabled after a power-on reset, however, the interrupt request is disabled. To enable the LVDI, the LVDDF and LVDUF bits in LVDSR must be cleared to 0 and the LVDDE or LVDUE bit in LVDCR must be set to 1. When using external compared voltage, write 0 to the VDDII bit in LVDCR, and wait for 50 μ s ($t_{LV\text{DON}}$) given by a software timer until the detection circuit has settled. Then clear the LVDDF and LVDUF bits to 0 and set the LVDDE or LVDUE bit to 1. After that, the output settings of ports must be made. The initial value of the external compared voltages input on the ExtU and ExtD pins must be higher than the Vexd voltage.

To cancel the LVDI, follow the procedures written in section 17.3.2 (4), Operating Procedures for Enabling/Disabling LVDR and LVDI Circuits.

When the external comparison voltage of ExtD pin falls below the Vexd (D) (Typ. = 1.15 V) voltage, the LVDI clears the $\overline{\text{LVDINT}}$ signal to 0 and sets the LVDDF bit in LVDSR to 1. If the LVDDE bit is 1 at this time, an IRQ0 interrupt request is generated. In this case, the necessary data must be saved in the external EEPROM, and a transition to standby mode or subsleep mode must be made. Until this processing is completed, the power supply voltage must be higher than the lower limit of the guaranteed operating voltage.

When the power-supply voltage does not fall below the Vreset1 (Typ. = 2.3 V) voltage and the input voltage of the ExtU pin rises above Vexd (Typ. = 1.15 V) voltage, the LVDI circuit sets the $\overline{\text{LVDINT}}$ signal to 1. If the LVDUE bit is 1 at this time, the LVDUF bit in LVDSR is set to 1 and an IRQ0 interrupt request is generated.

If the power supply voltage falls below the Vreset1 (Typ. = 2.3 V) voltage, this LSI enters low-voltage detection reset operation. When the voltages input on the ExtU and ExtD pins are used as the compared voltage, ensure to use the LVDR (reset detection voltage: Typ. = 2.3 V) circuit.

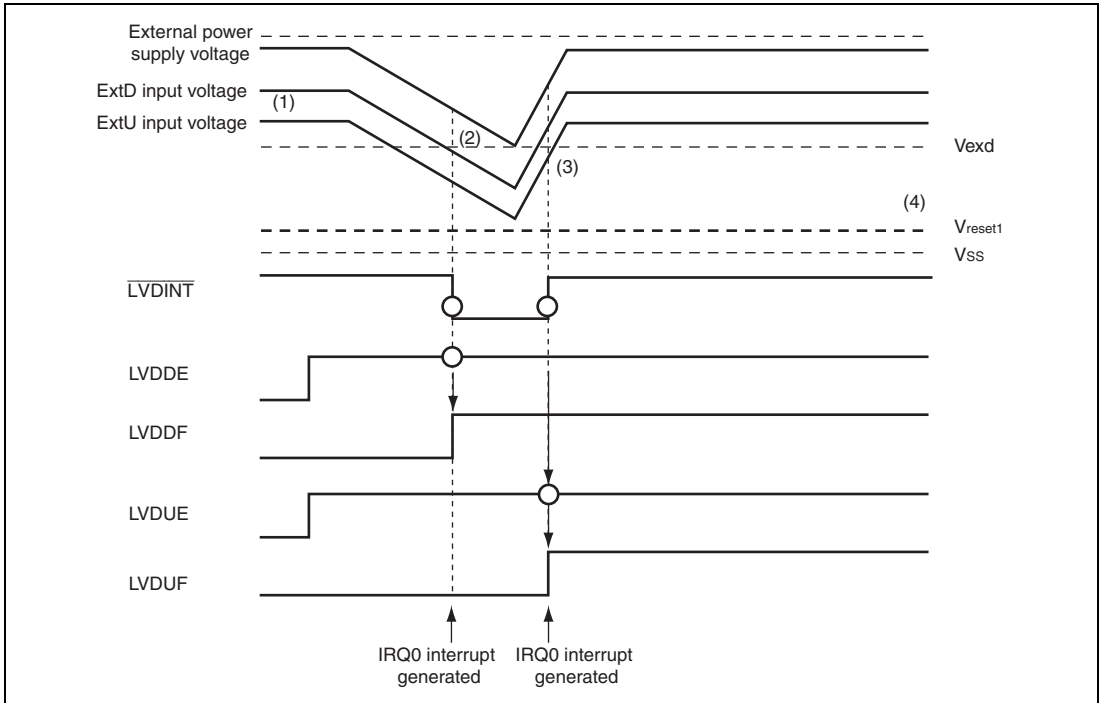

Figure 17.6 Operational Timing of LVDI Circuit (When Compared Voltage is Input through ExtU and ExtD Pins)

(4) Operating Procedures for Enabling/Disabling LVDR and LVDI Circuits

The low-voltage detection circuit is enabled after reset. To enable or disable the low-voltage detection circuit correctly, follow the procedure described below. Figure 17.7 shows the timing for the operation and release of the low-voltage detection circuit.

1. To disable the low-voltage detection circuit, clear all of the LVDRE, LVDDE, and LVDUE bits to 0. Then, clear the LVDE and BGRE bits to 0. Set the VDDII bit in LVDCR if necessary. The LVDE and BGRE bits must not be cleared to 0 at the same timing as the LVDRE, LVDDE, and LVDUE bits because incorrect operation may occur.
2. To enable the low-voltage detection circuit, set the LVDE and BGRE bits in LVDCR to 1. When the voltages input on the ExtU and ExtD pins are used as the compared voltage, clear the LVDDII bit to 0.
3. Wait for $50\ \mu\text{s}$ (t_{LVDon}) given by a software timer until the reference voltage and the low-voltage-detection power supply have settled. Then, clear the LVDDF and LVDUF bits in LVDSR to 0 and set the LVDRE, LVDDE, and LVDUE bits in LVDCR to 1, if necessary.

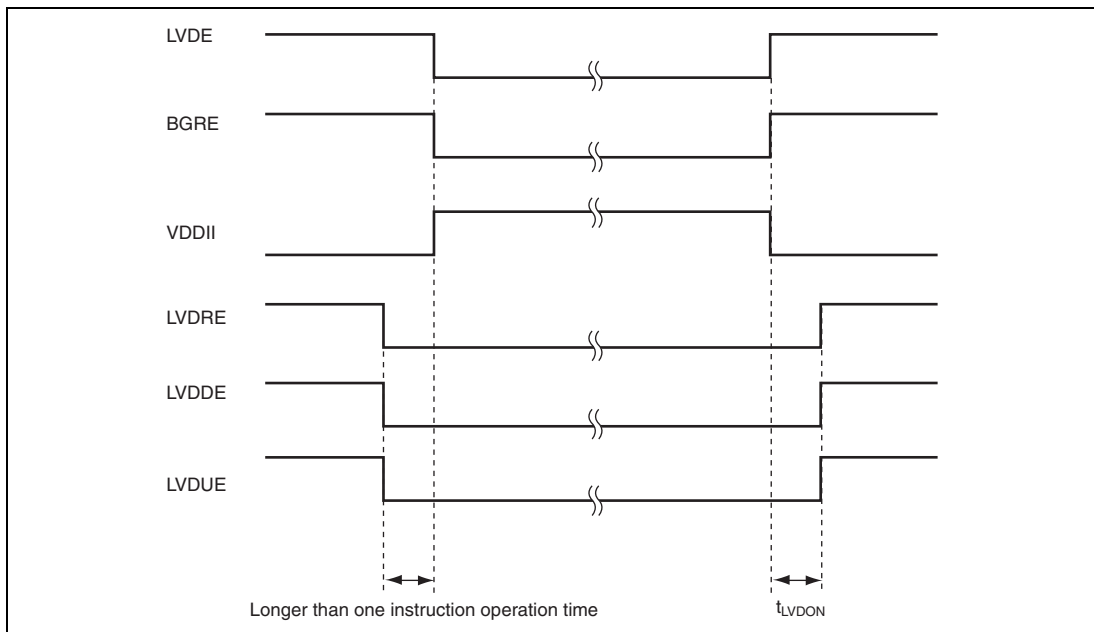

Figure 17.7 Timing for Enabling/Disabling of Low-Voltage Detection Circuit

Section 18 Power Supply Circuit

This LSI incorporates an internal power supply step-down circuit. Use of this circuit enables the internal power supply to be fixed at a constant level of approximately 3.0 V, independently of the voltage of the power supply connected to the external V_{CC} pin. As a result, the current consumed when an external power supply is used at 3.0 V or above can be held down to virtually the same low level as when used at approximately 3.0 V. If the external power supply is 3.0 V or below, the internal voltage will be practically the same as the external voltage. It is, of course, also possible to use the same level of external power supply voltage and internal power supply voltage without using the internal power supply step-down circuit.

18.1 When Using Internal Power Supply Step-Down Circuit

Connect the external power supply to the V_{CC} pin, and connect a capacitance of approximately 0.1 μF between V_{CL} and V_{SS} , as shown in figure 18.1. The internal step-down circuit is made effective simply by adding this external circuit. In the external circuit interface, the external power supply voltage connected to V_{CC} and the GND potential connected to V_{SS} are the reference levels. For example, for port input/output levels, the V_{CC} level is the reference for the high level, and the V_{SS} level is that for the low level. The A/D converter analog power supply is not affected by the internal step-down circuit.

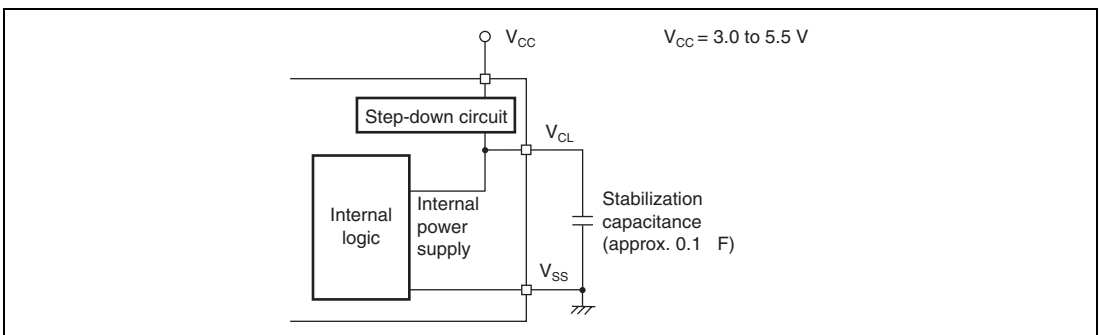

Figure 18.1 Power Supply Connection when Internal Step-Down Circuit is Used

18.2 When Not Using Internal Power Supply Step-Down Circuit

When the internal power supply step-down circuit is not used, connect the external power supply to the V_{CL} pin and V_{CC} pin, as shown in figure 18.2. The external power supply is then input directly to the internal power supply. The permissible range for the power supply voltage is 3.0 V to 3.6 V. Operation cannot be guaranteed if a voltage outside this range (less than 3.0 V or more than 3.6 V) is input.

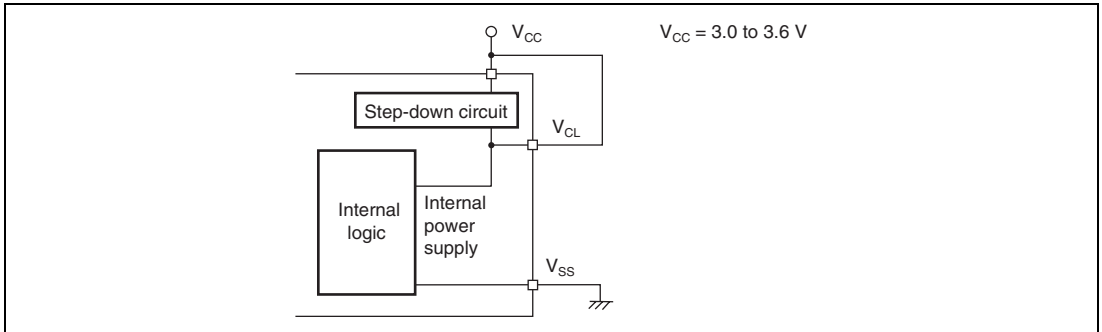

Figure 18.2 Power Supply Connection when Internal Step-Down Circuit is Not Used

Section 19 List of Registers

The register list gives information on the on-chip I/O register addresses, how the register bits are configured, and the register states in each operating mode. The information is given as shown below.

1. Register addresses (address order)
 - Registers are listed from the lower allocation addresses.
 - Registers are classified by functional modules.
 - The data bus width is indicated.
 - The number of access states is indicated.
2. Register bits
 - Bit configurations of the registers are described in the same order as the register addresses.
 - Reserved bits are indicated by — in the bit name column.
 - When registers consist of 16 bits, bits are described from the MSB side.
3. Register states in each operating mode
 - Register states are described in the same order as the register addresses.
 - The register states described here are for the basic operating modes. If there is a specific reset for an on-chip peripheral module, refer to the section on that on-chip peripheral module.

19.1 Register Addresses (Address Order)

The data bus width indicates the numbers of bits by which the register is accessed.

The number of access states indicates the number of states based on the specified reference clock.

Register Name	Abbre- viation	Bit No	Address	Module Name	Data Bus Width	Access State
Low-voltage-detection control register	LVDCR	8	H'F730	Low-voltage detection circuit	8	2
Low-voltage-detection status register	LVDSR	8	H'F731	Low-voltage detection circuit	8	2
Clock control status register	CKCSR	8	H'F734	Clock oscillator	8	2
RC control register	RCCR	8	H'F735	On-chip oscillator	8	2
RC trimming data protect register	RCTRMDPR	8	H'F736	On-chip oscillator	8	2
RC trimming data register	RCTRMDR	8	H'F737	On-chip oscillator	8	2
I ² C bus control register 1	ICCR1	8	H'F748	IIC2	8	2
I ² C bus control register 2	ICCR2	8	H'F749	IIC2	8	2
I ² C bus mode register	ICMR	8	H'F74A	IIC2	8	2
I ² C bus interrupt enable register	ICIER	8	H'F74B	IIC2	8	2
I ² C bus status register	ICSR	8	H'F74C	IIC2	8	2
Slave address register	SAR	8	H'F74D	IIC2	8	2
I ² C bus transmit data register	ICDRT	8	H'F74E	IIC2	8	2
I ² C bus receive data register	ICDRR	8	H'F74F	IIC2	8	2
Timer mode register B1	TMB1	8	H'F760	Timer B1	8	2
Timer counter B1/Timer load register B1	TCB1(R)/ TLB1 (W)	8	H'F761	Timer B1	8	2
Timer mode register W	TMRW	8	H'FF80	Timer W	8	2
Timer control register W	TCRW	8	H'FF81	Timer W	8	2
Timer interrupt enable register W	TIERW	8	H'FF82	Timer W	8	2
Timer status register W	TSRW	8	H'FF83	Timer W	8	2

Register Name	Abbreviation	Bit No	Address	Module Name	Data Bus Width	Access State
Timer I/O control register 0	TIOR0	8	H'FF84	Timer W	8	2
Timer I/O control register 1	TIOR1	8	H'FF85	Timer W	8	2
Timer counter	TCNT	16	H'FF86	Timer W	16* ¹	2
General register A	GRA	16	H'FF88	Timer W	16* ¹	2
General register B	GRB	16	H'FF8A	Timer W	16* ¹	2
General register C	GRC	16	H'FF8C	Timer W	16* ¹	2
General register D	GRD	16	H'FF8E	Timer W	16* ¹	2
Flash memory control register 1	FLMCR1	8	H'FF90	ROM	8	2
Flash memory control register 2	FLMCR2	8	H'FF91	ROM	8	2
Erase block register 1	EBR1	8	H'FF93	ROM	8	2
Flash memory enable register	FENR	8	H'FF9B	ROM	8	2
Timer control register V0	TCRV0	8	H'FFA0	Timer V	8	3
Timer control/status register V	TCSR V	8	H'FFA1	Timer V	8	3
Timer constant register A	TCORA	8	H'FFA2	Timer V	8	3
Timer constant register B	TCORB	8	H'FFA3	Timer V	8	3
Timer counter V	TCNTV	8	H'FFA4	Timer V	8	3
Timer control register V1	TCRV1	8	H'FFA5	Timer V	8	3
Serial mode register	SMR	8	H'FFA8	SCI3	8	3
Bit rate register	BRR	8	H'FFA9	SCI3	8	3
Serial control register 3	SCR3	8	H'FFAA	SCI3	8	3
Transmit data register	TDR	8	H'FFAB	SCI3	8	3
Serial status register	SSR	8	H'FFAC	SCI3	8	3
Receive data register	RDR	8	H'FFAD	SCI3	8	3
Sampling mode register	SPMR	8	H'FFAE	SCI3	8	3
A/D data register A	ADDRA	16	H'FFB0	A/D converter	8	3
A/D data register B	ADDRB	16	H'FFB2	A/D converter	8	3
A/D data register C	ADDRC	16	H'FFB4	A/D converter	8	3
A/D data register D	ADDRD	16	H'FFB6	A/D converter	8	3
A/D control/status register	ADCSR	8	H'FFB8	A/D converter	8	3
A/D control register	ADCR	8	H'FFB9	A/D converter	8	3
Timer control/status register WD	TCSRWD	8	H'FFC0	WDT* ²	8	2

Register Name	Abbreviation	Bit No	Address	Module Name	Data Bus Width	Access State
Timer counter WD	TCWD	8	H'FFC1	WDT* ²	8	2
Timer mode register WD	TMWD	8	H'FFC2	WDT* ²	8	2
Address break control register	ABRKCR	8	H'FFC8	Address break	8	2
Address break status register	ABRKSR	8	H'FFC9	Address break	8	2
Break address register H	BARH	8	H'FFCA	Address break	8	2
Break address register L	BARL	8	H'FFCB	Address break	8	2
Break data register H	BDRH	8	H'FFCC	Address break	8	2
Break data register L	BDRL	8	H'FFCD	Address break	8	2
Port pull-up control register 1	PUCR1	8	H'FFD0	I/O port	8	2
Port pull-up control register 5	PUCR5	8	H'FFD1	I/O port	8	2
Port data register 1	PDR1	8	H'FFD4	I/O port	8	2
Port data register 2	PDR2	8	H'FFD5	I/O port	8	2
Port data register 5	PDR5	8	H'FFD8	I/O port	8	2
Port data register 7	PDR7	8	H'FFDA	I/O port	8	2
Port data register 8	PDR8	8	H'FFDB	I/O port	8	2
Port data register B	PDRB	8	H'FFDD	I/O port	8	2
Port data register C	PDRC	8	H'FFDE	I/O port	8	2
Port mode register 1	PMR1	8	H'FFE0	I/O port	8	2
Port mode register 5	PMR5	8	H'FFE1	I/O port	8	2
Port control register 1	PCR1	8	H'FFE4	I/O port	8	2
Port control register 2	PCR2	8	H'FFE5	I/O port	8	2
Port control register 5	PCR5	8	H'FFE8	I/O port	8	2
Port control register 7	PCR7	8	H'FFEA	I/O port	8	2
Port control register 8	PCR8	8	H'FFEB	I/O port	8	2
Port control register C	PCRC	8	H'FFEE	I/O port	8	2
System control register 1	SYSCR1	8	H'FFF0	Power-down	8	2
System control register 2	SYSCR2	8	H'FFF1	Power-down	8	2
Interrupt edge select register 1	IEGR1	8	H'FFF2	Interrupts	8	2
Interrupt edge select register 2	IEGR2	8	H'FFF3	Interrupts	8	2
Interrupt enable register 1	IENR1	8	H'FFF4	Interrupts	8	2
Interrupt enable register 2	IENR2	8	H'FFF5	Interrupts	8	2

Register Name	Abbreviation	Bit No	Address	Module Name	Data Bus Width	Access State
Interrupt flag register 1	IRR1	8	H'FFF6	Interrupts	8	2
Interrupt flag register 2	IRR2	8	H'FFF7	Interrupts	8	2
Wake-up interrupt flag register	IWPR	8	H'FFF8	Interrupts	8	2
Module standby control register 1	MSTCR1	8	H'FFF9	Power-down	8	2
Module standby control register 2	MSTCR2	8	H'FFFA	Power-down	8	2

Notes: 1. Only word access can be used.

2. WDT: Watchdog timer

19.2 Register Bits

Register bit names of the on-chip peripheral modules are described below.

Each line covers eight bits, and 16-bit registers are shown as 2 lines.

Register Name	Bit 7	Bit 6	Bit 5	Bit 4	Bit 3	Bit 2	Bit 1	Bit 0	Module Name
LVDCR	LVDE	BGRE	VDDII	—	LVDSEL	LVDRE	LVDDE	LVDUE	LVDC
LVDSR	—	—	—	—	—	—	LVDDF	LVDUF	
CKCSR	PMRC1	PMRC0	—	OSCSEL	CKSWIE	CKSWIF	—	CKSTA	Clock oscillator
RCCR	RCSTP	FSEL	VCLSEL	—	—	—	RCPSC1	RCPSC0	On-chip oscillator
RCTRMDPR	WRI	PRWE	LOCKDW	TRMDRWE	—	—	—	—	
RCTRMDR	TRMD7	TRMD6	TRMD5	TRMD4	TRMD3	TRMD2	TRMD1	TRMD0	
ICCR1	ICE	RCVD	MST	TRS	CKS3	CKS2	CKS1	CKS0	IIC2
ICCR2	BBSY	SCP	SDAO	SDAOP	SCLO	—	IICRST	—	
ICMR	MLS	WAIT	—	—	BCWP	BC2	BC1	BC0	
ICIER	TIE	TEIE	RIE	NAKIE	STIE	ACKE	ACKBR	ACKBT	
ICSR	TDRE	TEND	RDRF	NACKF	STOP	AL/OVE	AAS	ADZ	
SAR	SVA6	SVA5	SVA4	SVA3	SVA2	SVA1	SVA0	FS	
ICDRT	ICDRT7	ICDRT6	ICDRT5	ICDRT4	ICDRT3	ICDRT2	ICDRT1	ICDRT0	
ICDRR	ICDRR7	ICDRR6	ICDRR5	ICDRR4	ICDRR3	ICDRR2	ICDRR1	ICDRR0	
TMB1	TMB17	—	—	—	—	TMB12	TMB11	TMB10	Timer B1
TCB1 (R)/ TLB1 (W)	BIT7	BIT6	BIT5	BIT4	BIT3	BIT2	BIT1	BIT0	
TMRW	CTS	—	BUFEB	BUFEA	—	PWMD	PWMC	PWMB	Timer W
TCRW	CCLR	CKS2	CKS1	CKS0	TOD	TOC	TOB	TOA	
TIERW	OVIE	—	—	—	IMIED	IMIEC	IMIEB	IMIEA	
TSRW	OVF	—	—	—	IMFD	IMFC	IMFB	IMFA	
TIOR0	—	IOB2	IOB1	IOB0	—	IOA2	IOA1	IOA0	
TIOR1	—	IOD2	IOD1	IOD0	—	IOC2	IOC1	IOC0	
TCNT	TCNT15	TCNT14	TCNT13	TCNT12	TCNT11	TCNT10	TCNT9	TCNT8	
	TCNT7	TCNT6	TCNT5	TCNT4	TCNT3	TCNT2	TCNT1	TCNT0	
GRA	GRA15	GRA14	GRA13	GRA12	GRA11	GRA10	GRA9	GRA8	
	GRA7	GRA6	GRA5	GRA4	GRA3	GRA2	GRA1	GRA0	
GRB	GRB15	GRB14	GRB13	GRB12	GRB11	GRB10	GRB9	GRB8	
	GRB7	GRB6	GRB5	GRB4	GRB3	GRB2	GRB1	GRB0	

Register Name	Bit 7	Bit 6	Bit 5	Bit 4	Bit 3	Bit 2	Bit 1	Bit 0	Module Name
GRC	GRC15	GRC14	GRC13	GRC12	GRC11	GRC10	GRC9	GRC8	Timer W
	GRC7	GRC6	GRC5	GRC4	GRC3	GRC2	GRC1	GRC0	
GRD	GRD15	GRD14	GRD13	GRD12	GRD11	GRD10	GRD9	GRD8	
	GRD7	GRD6	GRD5	GRD4	GRD3	GRD2	GRD1	GRD0	
FLMCR1	—	SWE	ESU	PSU	EV	PV	E	P	ROM
FLMCR2	FLER	—	—	—	—	—	—	—	
EBR1	—	—	EB5	EB4	EB3	EB2	EB1	EB0	
FENR	FLSHE	—	—	—	—	—	—	—	
TCRV0	CMIEB	CMIEA	OVIE	CCLR1	CCLR0	CKS2	CKS1	CKS0	Timer V
TCSRv	CMFB	CMFA	OVF	—	OS3	OS2	OS1	OS0	
TCORA	TCORA7	TCORA6	TCORA5	TCORA4	TCORA3	TCORA2	TCORA1	TCORA0	
TCORB	TCORB7	TCORB6	TCORB5	TCORB4	TCORB3	TCORB2	TCORB1	TCORB0	
TCNTV	TCNTV7	TCNTV6	TCNTV5	TCNTV4	TCNTV3	TCNTV2	TCNTV1	TCNTV0	
TCRV1	—	—	—	TVEG1	TVEG0	TRGE	—	ICKS0	
SMR	COM	CHR	PE	PM	STOP	MP	CKS1	CKS0	SCI3
BRR	BRR7	BRR6	BRR5	BRR4	BRR3	BRR2	BRR1	BRR0	
SCR3	TIE	RIE	TE	RE	MPIE	TEIE	CKE1	CKE0	
TDR	TDR7	TDR6	TDR5	TDR4	TDR3	TDR2	TDR1	TDR0	
SSR	TDRE	RDRF	OER	FER	PER	TEND	MPBR	MPBT	
RDR	RDR7	RDR6	RDR5	RDR4	RDR3	RDR2	RDR1	RDR0	
SPMR	—	—	—	—	—	STDSPM	—	—	
ADDRA	AD9	AD8	AD7	AD6	AD5	AD4	AD3	AD2	A/D converter
	AD1	AD0	—	—	—	—	—	—	
ADDRB	AD9	AD8	AD7	AD6	AD5	AD4	AD3	AD2	
	AD1	AD0	—	—	—	—	—	—	
ADDRC	AD9	AD8	AD7	AD6	AD5	AD4	AD3	AD2	
	AD1	AD0	—	—	—	—	—	—	
ADDRD	AD9	AD8	AD7	AD6	AD5	AD4	AD3	AD2	
	AD1	AD0	—	—	—	—	—	—	
ADCSR	ADF	ADIE	ADST	SCAN	CKS	CH2	CH1	CH0	
ADCR	TRGE	—	—	—	—	—	—	—	
TCSRWD	B6WI	TCWE	B4WI	TCSRWE	B2WI	WDON	B0WI	WRST	WDT*
TCWD	TCWD7	TCWD6	TCWD5	TCWD4	TCWD3	TCWD2	TCWD1	TCWD0	
TMWD	—	—	—	—	CKS3	CKS2	CKS1	CKS0	

Register Name	Bit 7	Bit 6	Bit 5	Bit 4	Bit 3	Bit 2	Bit 1	Bit 0	Module Name
ABRKCR	RTINTE	CSEL1	CSEL0	ACMP2	ACMP1	ACMP0	DCMP1	DCMP0	Address break
ABRKSr	ABIF	ABIE	—	—	—	—	—	—	
BARH	BARH7	BARH6	BARH5	BARH4	BARH3	BARH2	BARH1	BARH0	I/O port
BARL	BARL7	BARL6	BARL5	BARL4	BARL3	BARL2	BARL1	BARL0	
BDRH	BDRH7	BDRH6	BDRH5	BDRH4	BDRH3	BDRH2	BDRH1	BDRH0	
BDRL	BDRL7	BDRL6	BDRL5	BDRL4	BDRL3	BDRL2	BDRL1	BDRL0	
PUCR1	PUCR17	—	—	PUCR14	—	—	—	—	
PUCR5	—	—	PUCR55	—	—	—	—	—	
PDR1	P17	—	—	P14	—	—	—	—	
PDR2	—	—	—	—	—	P22	P21	P20	
PDR5	P57	P56	P55	—	—	—	—	—	
PDR7	—	P76	P75	P74	—	—	—	—	
PDR8	—	—	—	P84	P83	P82	P81	P80	
PDRB	—	—	—	—	PB3	PB2	PB1	PB0	
PDRC	—	—	—	—	—	—	PC1	PC0	
PMR1	IRQ3	—	—	IRQ0	—	—	TXD	—	
PMR5	—	—	WKP5	—	—	—	—	—	
PCR1	PCR17	—	—	PCR14	—	—	—	—	
PCR2	—	—	—	—	—	PCR22	PCR21	PCR20	
PCR5	PCR57	PCR56	PCR55	—	—	—	—	—	
PCR7	—	PCR76	PCR75	PCR74	—	—	—	—	
PCR8	—	—	—	PCR84	PCR83	PCR82	PCR81	PCR80	
PCRC	—	—	—	—	—	—	PCRC1	PCRC0	
SYSCR1	SSBY	STS2	STS1	STS0	—	—	—	—	Power-down
SYSCR2	SMSEL	—	DTON	MA2	MA1	MA0	—	—	
IEGR1	—	—	—	—	IEG3	—	—	IEG0	Interrupts
IEGR2	—	—	WPEG5	—	—	—	—	—	
IENR1	IENDT	—	IENWP	—	IEN3	—	—	IEN0	
IENR2	—	—	IENRB1	—	—	—	—	—	
IRR1	IRRDT	—	—	—	IRRI3	—	—	IRRI0	
IRR2	—	—	IRRTB1	—	—	—	—	—	
IWPR	—	—	IWPF5	—	—	—	—	—	
MSTCR1	—	MSTIIC	MSTS3	MSTAD	MSTWD	MSTTW	MSTTV	—	Power-down
MSTCR2	—	—	—	MSTTB1	—	—	—	—	

Note: * WDT: Watchdog timer

19.3 Register States in Each Operating Mode

Register Name	Reset	Active	Sleep	Subsleep	Standby	Module
LVDCR	Initialized	—	—	—	—	LVDC
LVDSR	Initialized	—	—	—	—	
CKCSR	Initialized	—	—	—	—	Clock oscillator
RCCR	Initialized	—	—	—	—	On-chip oscillation
RCTRMDPR	Initialized	—	—	—	—	
RCTRMDR	Initialized	—	—	—	—	
ICCR1	Initialized	—	—	—	—	IIC2
ICCR2	Initialized	—	—	—	—	
ICMR	Initialized	—	—	—	—	
ICIER	Initialized	—	—	—	—	
ICSR	Initialized	—	—	—	—	
SAR	Initialized	—	—	—	—	
ICDRT	Initialized	—	—	—	—	
ICDRR	Initialized	—	—	—	—	
TMB1	Initialized	—	—	—	—	Timer B1
TCB1/TLB1	Initialized	—	—	—	—	
TMRW	Initialized	—	—	—	—	Timer W
TCRW	Initialized	—	—	—	—	
TIERW	Initialized	—	—	—	—	
TSRW	Initialized	—	—	—	—	
TIOR0	Initialized	—	—	—	—	
TIOR1	Initialized	—	—	—	—	
TCNT	Initialized	—	—	—	—	
GRA	Initialized	—	—	—	—	
GRB	Initialized	—	—	—	—	
GRC	Initialized	—	—	—	—	
GRD	Initialized	—	—	—	—	
FLMCR1	Initialized	—	—	Initialized	Initialized	ROM
FLMCR2	Initialized	—	—	Initialized	Initialized	
EBR1	Initialized	—	—	Initialized	Initialized	
FENR	Initialized	—	—	Initialized	Initialized	
TCRV0	Initialized	—	—	Initialized	Initialized	Timer V

Register Name	Reset	Active	Sleep	Subsleep	Standby	Module
TCSR_V	Initialized	—	—	Initialized	Initialized	Timer V
TCORA	Initialized	—	—	Initialized	Initialized	
TCORB	Initialized	—	—	Initialized	Initialized	
TCNTV	Initialized	—	—	Initialized	Initialized	
TCRV1	Initialized	—	—	Initialized	Initialized	
SMR	Initialized	—	—	Initialized	Initialized	
BRR	Initialized	—	—	Initialized	Initialized	
SCR3	Initialized	—	—	Initialized	Initialized	
TDR	Initialized	—	—	Initialized	Initialized	
SSR	Initialized	—	—	Initialized	Initialized	
RDR	Initialized	—	—	Initialized	Initialized	
SPMR	Initialized	—	—	Initialized	Initialized	
ADDRA	Initialized	—	—	Initialized	Initialized	A/D converter
ADDRB	Initialized	—	—	Initialized	Initialized	
ADDRC	Initialized	—	—	Initialized	Initialized	
ADDRD	Initialized	—	—	Initialized	Initialized	
ADCSR	Initialized	—	—	Initialized	Initialized	
ADCR	Initialized	—	—	Initialized	Initialized	
TCSRWD	Initialized	—	—	—	—	
TCWD	Initialized	—	—	—	—	Address Break
TMWD	Initialized	—	—	—	—	
ABRKCR	Initialized	—	—	—	—	
ABRKSR	Initialized	—	—	—	—	
BARH	Initialized	—	—	—	—	
BARL	Initialized	—	—	—	—	
BDRH	Initialized	—	—	—	—	
BDRL	Initialized	—	—	—	—	
PUCR1	Initialized	—	—	—	—	
PUCR5	Initialized	—	—	—	—	
PDR1	Initialized	—	—	—	—	
PDR2	Initialized	—	—	—	—	
PDR5	Initialized	—	—	—	—	
PDR7	Initialized	—	—	—	—	
PDR8	Initialized	—	—	—	—	
PDRB	Initialized	—	—	—	—	

Register Name	Reset	Active	Sleep	Subsleep	Standby	Module
PDRC	Initialized	—	—	—	—	I/O port
PMR1	Initialized	—	—	—	—	
PMR5	Initialized	—	—	—	—	
PCR1	Initialized	—	—	—	—	
PCR2	Initialized	—	—	—	—	
PCR5	Initialized	—	—	—	—	
PCR7	Initialized	—	—	—	—	
PCR8	Initialized	—	—	—	—	
PCRC	Initialized	—	—	—	—	
SYSCR1	Initialized	—	—	—	—	Power-down
SYSCR2	Initialized	—	—	—	—	
IEGR1	Initialized	—	—	—	—	Interrupts
IEGR2	Initialized	—	—	—	—	
IENR1	Initialized	—	—	—	—	
IENR2	Initialized	—	—	—	—	
IRR1	Initialized	—	—	—	—	
IRR2	Initialized	—	—	—	—	
IWPR	Initialized	—	—	—	—	
MSTCR1	Initialized	—	—	—	—	Power-down
MSTCR2	Initialized	—	—	—	—	

Note: — is not initialized

* WDT: Watchdog timer

Section 20 Electrical Characteristics

20.1 Absolute Maximum Ratings

Table 20.1 Absolute Maximum Ratings

Item	Symbol	Value	Unit	Note
Power supply voltage	V_{CC}	-0.3 to +7.0	V	*
Analog power supply voltage	AV_{CC}	-0.3 to +7.0	V	
Input voltage	Ports other than port B	V_{IN}	-0.3 to $V_{CC} + 0.3$	V
	Port B		-0.3 to $AV_{CC} + 0.3$	V
Operating temperature	T_{opr}	-20 to +75	°C	
Storage temperature	T_{stg}	-55 to +125	°C	

Note: * Permanent damage may result if maximum ratings are exceeded. Normal operation should be under the conditions specified in Electrical Characteristics. Exceeding these values can result in incorrect operation and reduced reliability.

20.2 Electrical Characteristics (F-ZTAT™ Version)

20.2.1 Power Supply Voltage and Operating Ranges

1. Supply voltage and external oscillation frequency range

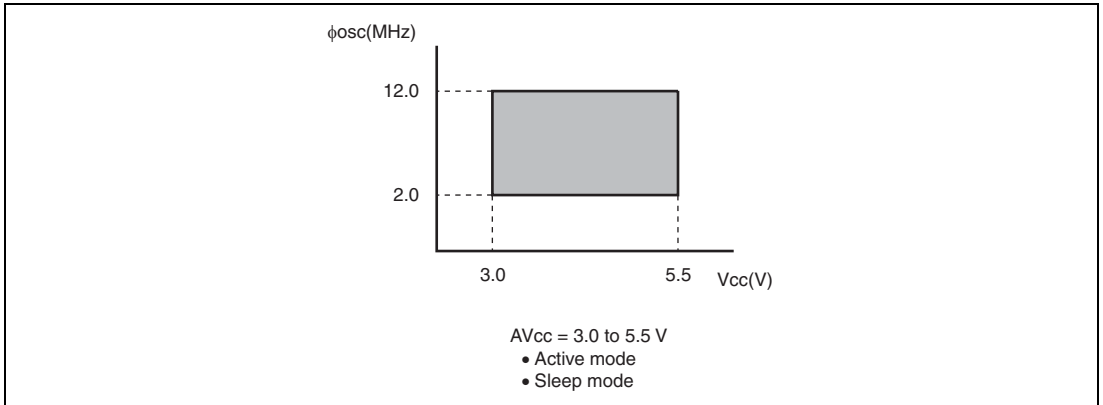

2. Power supply voltage and operating frequency range

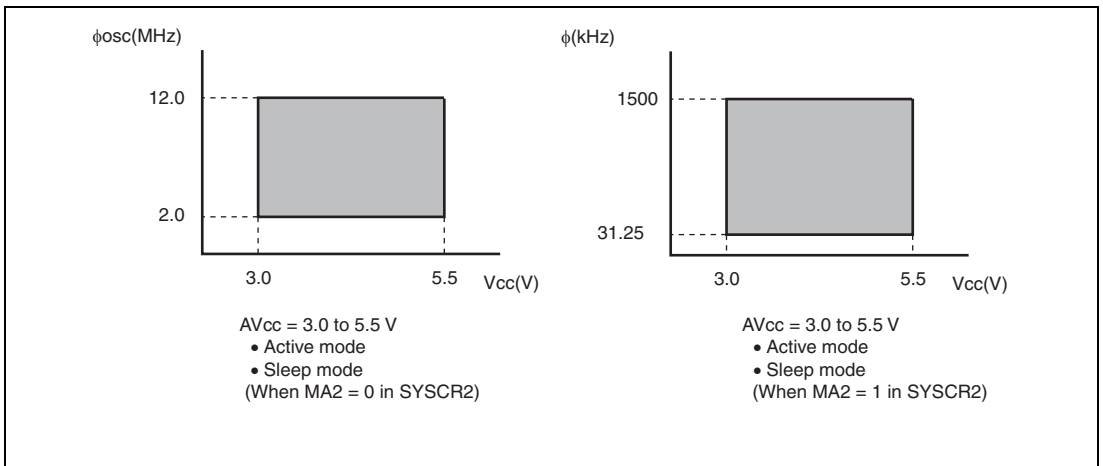

3. Analog power supply voltage and A/D converter accuracy guarantee range

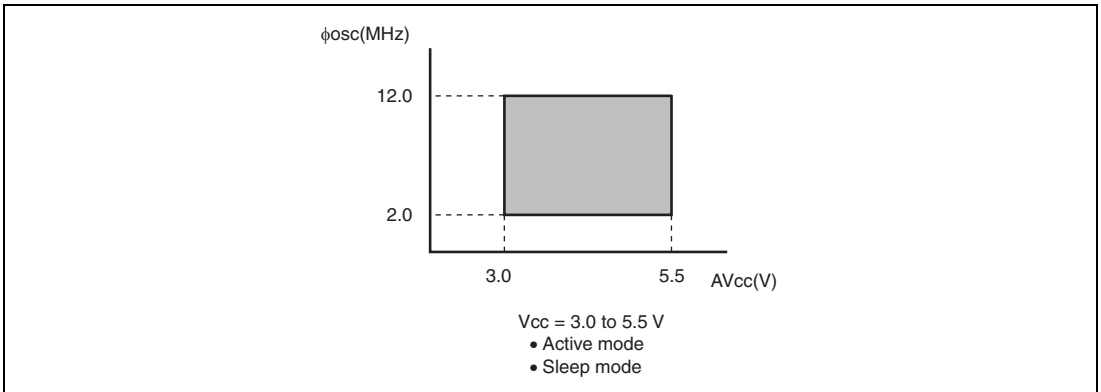

20.2.2 DC Characteristics

Table 20.2 DC Characteristics (1)

$V_{CC} = 3.0\text{ V to }5.5\text{ V}$, $V_{SS} = 0.0\text{ V}$, $T_a = -20^\circ\text{C to }+75^\circ\text{C}$ unless otherwise indicated.

Item	Symbol	Applicable Pins	Test Condition	Values			Unit	Notes
				Min.	Typ.	Max.		
Input high voltage	V_{IH}	RES, NMI, WKP5, IRQ0, IRQ3, ADTRG, TMRIV, TMCIV, FTCl, FTIOA to FTIOD, SCK3, TRGV	$V_{CC} = 4.0\text{ V to }5.5\text{ V}$	$V_{CC} \times 0.8$	—	$V_{CC} + 0.3$	V	
				$V_{CC} \times 0.9$	—	$V_{CC} + 0.3$	V	
		RXD, SCL, SDA, P17, P14, P22 to P20, P57 to P55, P76 to P74, P84 to P80, PC1, PC0	$V_{CC} = 4.0\text{ V to }5.5\text{ V}$	$V_{CC} \times 0.7$	—	$V_{CC} + 0.3$	V	
				$V_{CC} \times 0.8$	—	$V_{CC} + 0.3$	V	
		PB3 to PB0	$AV_{CC} = 4.0\text{ V to }5.5\text{ V}$	$AV_{CC} \times 0.7$	—	$AV_{CC} + 0.3$	V	
			$AV_{CC} = 3.0\text{ V to }5.5\text{ V}$	$AV_{CC} \times 0.8$	—	$AV_{CC} + 0.3$	V	
OSC1	$V_{CC} = 4.0\text{ V to }5.5\text{ V}$	$V_{CC} - 0.5$	—	$V_{CC} + 0.3$	V			
		$V_{CC} - 0.3$	—	$V_{CC} + 0.3$	V			
Input low voltage	V_{IL}	RES, NMI, WKP5, IRQ0, IRQ3, ADTRG, TMRIV, TMCIV, FTCl, FTIOA to FTIOD, SCK3, TRGV	$V_{CC} = 4.0\text{ V to }5.5\text{ V}$	-0.3	—	$V_{CC} \times 0.2$	V	
				-0.3	—	$V_{CC} \times 0.1$	V	
		RXD, SCL, SDA, P17, P14, P22 to P20, P57 to P55, P76 to P74, P84 to P80, PC1, PC0	$V_{CC} = 4.0\text{ V to }5.5\text{ V}$	-0.3	—	$V_{CC} \times 0.3$	V	
				-0.3	—	$V_{CC} \times 0.2$	V	
		PB3 to PB0	$AV_{CC} = 4.0\text{ V to }5.5\text{ V}$	-0.3	—	$AV_{CC} \times 0.3$	V	
			$AV_{CC} = 3.0\text{ V to }5.5\text{ V}$	-0.3	—	$AV_{CC} \times 0.2$	V	
OSC1	$V_{CC} = 4.0\text{ V to }5.5\text{ V}$	-0.3	—	0.5	V			
		-0.3	—	0.3	V			

Item	Symbol	Applicable Pins	Test Condition	Values			Unit	Notes	
				Min.	Typ.	Max.			
Output high voltage	V_{OH}	P17, P14, P22 to P20, P55, P76 to P74, P84 to P80, PC1, PC0	$V_{CC} = 4.0 \text{ V to } 5.5 \text{ V}$ $-I_{OH} = 4 \text{ mA}$	$V_{CC} - 1.0$	—	—	V		
			$-I_{OH} = 0.1 \text{ mA}$	$V_{CC} - 0.5$	—	—	V		
		P56, P57	$V_{CC} = 4.0 \text{ V to } 5.5 \text{ V}$ $-I_{OH} = 0.1 \text{ mA}$	$V_{CC} - 2.5$	—	—	V		
			$V_{CC} = 3.0 \text{ V to } 4.0 \text{ V}$ $-I_{OH} = 0.1 \text{ mA}$	$V_{CC} - 2.2$	—	—	V		
Output low voltage	V_{OL}	P17, P14, P22 to P20, P57 to P55, P76 to P74, PC1, PC0	$V_{CC} = 4.0 \text{ V to } 5.5 \text{ V}$ $I_{OL} = 1.6 \text{ mA}$	—	—	0.6	V		
			$I_{OL} = 0.4 \text{ mA}$	—	—	0.4	V		
			P84 to P80	$V_{CC} = 4.0 \text{ V to } 5.5 \text{ V}$ $I_{OL} = 20.0 \text{ mA}$	—	—	1.5	V	
		$V_{CC} = 4.0 \text{ V to } 5.5 \text{ V}$ $I_{OL} = 10.0 \text{ mA}$		—	—	1.0	V		
		SCL, SDA	$V_{CC} = 4.0 \text{ V to } 5.5 \text{ V}$ $I_{OL} = 1.6 \text{ mA}$	—	—	0.4	V		
			$I_{OL} = 0.4 \text{ mA}$	—	—	0.4	V		
			$I_{OL} = 3.0 \text{ mA}$	—	—	0.4	V		
		Input/output leakage current	$ I_{IL} $	OSC1, \overline{NMI} , $\overline{WKP5}$, $\overline{IRQ0}$, $\overline{IRQ3}$, \overline{ADTRG} , TRGV, TMRIV, TMCIV, FTCL, FTIOA to FTIOD, RXD, SCK3, SCL, SDA	$V_{IN} = 0.5 \text{ V to } (V_{CC} - 0.5 \text{ V})$	—	—	1.0	μA
P17, P14, P22 to P20, P57 to P55, P76 to P74, P84 to P80, PC1, PC0	$V_{IN} = 0.5 \text{ V to } (V_{CC} - 0.5 \text{ V})$				—	—	1.0	μA	
PB3 to PB0	$V_{IN} = 0.5 \text{ V to } (AV_{CC} - 0.5 \text{ V})$				—	—	1.0	μA	

Item	Symbol	Applicable Pins	Test Condition	Values			Unit	Notes
				Min.	Typ.	Max.		
Pull-up MOS current	$-I_p$	P17, P14, P55	$V_{CC} = 5.0 V$, $V_{IN} = 0.0 V$	50.0	—	300.0	μA	
			$V_{CC} = 3.0 V$, $V_{IN} = 0.0 V$	—	60.0	—	μA	Reference value
Input capacitance	C_{in}	All input pins except power supply pins	$f = 1 MHz$, $V_{IN} = 0.0 V$, $T_a = 25^\circ C$	—	—	15.0	pF	
Active mode current consumption	I_{OPE1}	V_{CC}	Active mode 1 $V_{CC} = 5.0 V$, $f_{OSC} = 12 MHz$	—	12.0	18.0	mA	*
			Active mode 1 $V_{CC} = 3.0 V$, $f_{OSC} = 12 MHz$	—	9.6	—	mA	Reference value*
	I_{OPE2}	V_{CC}	Active mode 2 $V_{CC} = 5.0 V$, $f_{OSC} = 12 MHz$	—	2.0	2.5	mA	*
			Active mode 2 $V_{CC} = 3.0 V$, $f_{OSC} = 12 MHz$	—	1.5	—	mA	Reference value*
Sleep mode current consumption	I_{SLEEP1}	V_{CC}	Sleep mode 1 $V_{CC} = 5.0 V$, $f_{OSC} = 12 MHz$	—	7.2	12.0	mA	*
			Sleep mode 1 $V_{CC} = 3.0 V$, $f_{OSC} = 12 MHz$	—	6.0	—	mA	Reference value*
	I_{SLEEP2}	V_{CC}	Sleep mode 2 $V_{CC} = 5.0 V$, $f_{OSC} = 12 MHz$	—	1.8	2.2	mA	*
			Sleep mode 2 $V_{CC} = 3.0 V$, $f_{OSC} = 12 MHz$	—	1.4	—	mA	Reference value*
Subsleep mode current consumption	I_{SUBSP}	V_{CC}	$V_{CC} = 5.0 V$ LVDE = 0, BGRE = 0	—	—	5.0	μA	*
Standby mode current consumption	I_{STBY}	V_{CC}	LVDE = 0, BGRE = 0	—	—	5.0	μA	*

Item	Symbol	Applicable Pins	Test Condition	Values			Unit	Notes
				Min.	Typ.	Max.		
RAM data retaining voltage	V_{RAM}	V_{CC}		2.0	—	—	V	

Note: * Pin states during current consumption measurement are given below (excluding current in the pull-up MOS transistors and output buffers).

Mode	\overline{RES} Pin	Internal State	Other Pins	Oscillator Pins
Active mode 1	V_{CC}	Operates	V_{CC}	System clock: Crystal or ceramic resonator, and on-chip oscillator
Active mode 2		Operates ($\phi/64$)		
Sleep mode 1	V_{CC}	Only timers operate	V_{CC}	
Sleep mode 2		Only timers operate ($\phi/64$)		
Subsleep mode Standby mode	V_{CC}	CPU and timers both stop	V_{CC}	—

Table 20.2 DC Characteristics (2)

$V_{CC} = 3.0\text{ V to }5.5\text{ V}$, $V_{SS} = 0.0\text{ V}$, $T_a = -20^\circ\text{C to }+75^\circ\text{C}$, unless otherwise indicated.

Item	Symbol	Application Pins	Test Condition	Values			Unit
				Min.	Typ.	Max.	
Allowable output low current (per pin)	I_{OL}	Output pins except P84 to P80, SCL, and SDA	$V_{CC} = 4.0\text{ V to }5.5\text{ V}$	—	—	2.0	mA
		P84 to P80		—	—	20.0	mA
		Output pins except P84 to P80, SCL, and SDA		—	—	0.5	mA
		P84 to P80		—	—	10.0	mA
		SCL, SDA		—	—	6.0	mA
Allowable output low current (total)	ΣI_{OL}	Output pins except P84 to P80, SCL, and SDA	$V_{CC} = 4.0\text{ V to }5.5\text{ V}$	—	—	40.0	mA
		P84 to P80, SCL, and SDA		—	—	80.0	mA
		Output pins except P84 to P80, SCL, and SDA		—	—	20.0	mA
		P84 to P80, SCL, and SDA		—	—	40.0	mA
Allowable output high current (per pin)	I_{OH}	Output pins except P56, P57	$V_{CC} = 4.0\text{ V to }5.5\text{ V}$	—	—	4.0	mA
				—	—	0.2	mA
		P56, P57	$V_{CC} = 4.0\text{ V to }5.5\text{ V}$	—	—	2.0	mA
				—	—	0.2	mA
Allowable output high current (total)	I_{OH}	All output pins	$V_{CC} = 4.0\text{ V to }5.5\text{ V}$	—	—	40.0	mA
				—	—	8.0	mA

20.2.3 AC Characteristics

Table 20.3 AC Characteristics
 $V_{CC} = 3.0\text{ V to }5.5\text{ V}$, $V_{SS} = 0.0\text{ V}$, $T_a = -20^\circ\text{C to }+75^\circ\text{C}$, unless otherwise specified.

Item	Symbol	Applicable Pins	Test Condition	Values			Unit	Reference Figure
				Min.	Typ.	Max.		
System clock oscillation frequency	f_{OSC}	OSC1, OSC2		2.0	—	12.0	MHz	
System clock (ϕ) cycle time	t_{cyc}			1	—	64	t_{OSC}	* ¹
				—	—	32.0	μs	Figure 20.1
Instruction cycle time				2	—	—	t_{cyc}	
Oscillation stabilization time (crystal resonator)	t_{rc}	OSC1, OSC2		—	—	10.0	ms	
Oscillation stabilization time (ceramic resonator)	t_{rc}	OSC1, OSC2		—	—	5.0	ms	
External clock high width	t_{CPH}	OSC1		35.0	—	—	ns	Figure 20.1
External clock low width	t_{CPL}	OSC1		35.0	—	—	ns	
External clock rise time	t_{CPr}	OSC1		—	—	15.0	ns	
External clock fall time	t_{CPf}	OSC1		—	—	15.0	ns	
$\overline{\text{RES}}$ pin low width* ⁴	t_{REL}	$\overline{\text{RES}}$		2500	—	—	ns	Figure 20.2
NMI pin high width	$t_{IH\text{NMI}}$	NMI		1500	—	—	ns	Figure 20.3
NMI pin low width	$t_{IL\text{NMI}}$	NMI		1500	—	—	ns	
Input pin high width	t_{IH}	$\overline{\text{IRQ0}}$, $\overline{\text{IRQ3}}$, $\overline{\text{WKP5}}$, TMCIV, TMRIV, TRGV, ADTRG, FTCl, FTIOA to FTIOD		2	—	—	t_{cyc}	Figure 20.3
Input pin low width	t_{IL}	$\overline{\text{IRQ0}}$, $\overline{\text{IRQ3}}$, $\overline{\text{WKP5}}$, TMCIV, TMRIV, TRGV, ADTRG, FTCl, FTIOA to FTIOD		2	—	—	t_{cyc}	

Item	Symbol	Applicable Pins	Test Condition	Values			Reference Figure
				Min.	Typ.	Max.	
On-chip oscillator oscillation frequency *2	f_{RC}		$V_{CC} = 5.0\text{ V}$ $T_a = 25^\circ\text{C}$ FSEL = 0, VCLSEL = 0	7.92*3	8.0	8.08*3	MHz
			$V_{CC} = 4.0\text{ V to }5.5\text{ V}$ FSEL = 0, VCLSEL = 0	7.76	8.0	8.24	MHz
			$V_{CC} = 4.0\text{ V to }5.5\text{ V}$ FSEL = 1, VCLSEL = 0	9.6*3	10.0	10.4*3	MHz

- Notes:
1. Determined by MA2 to MA0 in system control register 2 (SYSCR2).
 2. For the oscillation frequency of the masked ROM version, refer to the electrical characteristics specified separately.
 3. The values are for reference.
 4. Except when power-on reset circuit is used.

Table 20.4 I²C Bus Interface Timing

$V_{CC} = 3.0$ to 5.5 V, $V_{SS} = 0.0$ V, $T_a = -20$ to $+75^\circ\text{C}$, unless otherwise indicated.

Item	Symbol	Applicable Pins	Test Condition	Values			Unit	Reference Figure
				Min.	Typ.	Max.		
SCL input cycle time	t_{SCL}			$12t_{cyc} + 600$	—	—	ns	Figure 20.4
SCL input high pulse width	t_{SCLH}			$3t_{cyc} + 300$	—	—	ns	
SCL input low pulse width	t_{SCLL}			$5t_{cyc} + 300$	—	—	ns	
SCL and SDA input fall time	t_{Sf}			—	—	300	ns	
SCL and SDA input spike pulse removal time	t_{SP}			—	—	$1t_{cyc}$	ns	
SDA input bus-free time	t_{BUF}			$5t_{cyc}$	—	—	ns	
Start condition input hold time	t_{STAH}			$3t_{cyc}$	—	—	ns	
Retransmission start condition input setup time	t_{STAS}			$3t_{cyc}$	—	—	ns	
Setup time for stop condition input	t_{STOS}			$3t_{cyc}$	—	—	ns	
Data input setup time	t_{SDAS}			$1t_{cyc} + 20$	—	—	ns	
Data input hold time	t_{SDAH}			0	—	—	ns	
Capacitive load of SCL and SDA	c_b			0	—	400	pF	
SCL and SDA output fall time	t_{Sf}	$V_{CC} = 4.0$ to 5.5 V	—	—	—	250	ns	
			—	—	—	300	ns	

Table 20.5 Serial Interface (SCI3) Timing

$V_{CC} = 3.0\text{ V}$ to 5.5 V , $V_{SS} = 0.0\text{ V}$, $T_a = -20^\circ\text{C}$ to $+75^\circ\text{C}$, unless otherwise specified.

Item	Symbol	Applicable Pins	Test Condition	Values			Unit	Reference Figure
				Min.	Typ.	Max.		
Input clock cycle	Asynchronous	t_{sync}	SCK3	4	—	—	t_{cyc}	Figure 20.5
	Clocked synchronous			6	—	—		
Input clock pulse width	t_{SCKW}	SCK3		0.4	—	0.6	t_{sync}	
Transmit data delay time (clocked synchronous)	t_{TXD}	TXD		—	—	1	t_{cyc}	Figure 20.6
Receive data setup time (clocked synchronous)	t_{RXS}	RXD		83.3	—	—	ns	
Receive data hold time (clocked synchronous)	t_{RXH}	RXD		83.3	—	—	ns	

20.2.4 A/D Converter Characteristics

Table 20.6 A/D Converter Characteristics

$V_{CC} = 3.0\text{ V to }5.5\text{ V}$, $V_{SS} = 0.0\text{ V}$, $T_a = -20^\circ\text{C to }+75^\circ\text{C}$, unless otherwise specified.

Item	Symbol	Applicable Pins	Test Condition	Values			Unit	Notes
				Min.	Typ.	Max.		
Analog power supply voltage	AV_{CC}	AV_{CC}		3.0	V_{CC}	5.5	V	*1
Analog input voltage	AV_{IN}	AN3 to AN0		$V_{SS} - 0.3$	—	$AV_{CC} + 0.3$	V	
Analog power supply current	AI_{OPE}	AV_{CC}	$AV_{CC} = 5.0\text{ V}$ $f_{OSC} = 12\text{ MHz}$	—	—	2.0	mA	
	AI_{STOP1}	AV_{CC}		—	50	—	μA	*2 Reference value
	AI_{STOP2}	AV_{CC}		—	—	5.0	μA	*3
Analog input capacitance	C_{AIN}	AN3 to AN0		—	—	30.0	pF	
Allowable signal source impedance	R_{AIN}	AN3 to AN0		—	—	5.0	k Ω	
Resolution (data length)				10	10	10	bit	
Conversion time (single mode)			$AV_{CC} = 3.0\text{ V to }5.5\text{ V}$	134	—	—	t_{cyc}	
Nonlinearity error				—	—	± 7.5	LSB	
Offset error				—	—	± 7.5	LSB	
Full-scale error				—	—	± 7.5	LSB	
Quantization error				—	—	± 0.5	LSB	
Absolute accuracy				—	—	± 8.0	LSB	
Conversion time (single mode)			$AV_{CC} = 4.0\text{ V to }5.5\text{ V}$	70	—	—	t_{cyc}	
Nonlinearity error				—	—	± 7.5	LSB	
Offset error				—	—	± 7.5	LSB	
Full-scale error				—	—	± 7.5	LSB	
Quantization error				—	—	± 0.5	LSB	
Absolute accuracy				—	—	± 8.0	LSB	

Item	Symbol	Applicable Pins	Test Condition	Values			Unit	Notes
				Min.	Typ.	Max.		
Conversion time (single mode)			$AV_{CC} = 4.0\text{ V}$ to 5.5 V	134	—	—	t_{cyc}	
Nonlinearity error				—	—	±3.5	LSB	
Offset error				—	—	±3.5	LSB	
Full-scale error				—	—	±3.5	LSB	
Quantization error				—	—	±0.5	LSB	
Absolute accuracy				—	—	±4.0	LSB	

- Notes:
1. Set $AV_{CC} = V_{CC}$ when the A/D converter is not used.
 2. AI_{STOP1} is the current in active and sleep modes while the A/D converter is idle.
 3. AI_{STOP2} is the current at reset and in standby and subsleep modes while the A/D converter is idle.

20.2.5 Watchdog Timer Characteristics

Table 20.7 Watchdog Timer Characteristics

$V_{CC} = 3.0\text{ V}$ to 5.5 V, $V_{SS} = 0.0\text{ V}$, $T_a = -20^\circ\text{C}$ to $+75^\circ\text{C}$, unless otherwise specified.

Item	Symbol	Applicable Pins	Test Condition	Values			Unit	Notes
				Min.	Typ.	Max.		
Internal oscillator overflow time	t_{OVF}			0.2	0.4	—	s	*

Note: * Shows the time to count from 0 to 255, at which point an internal reset is generated, when the internal oscillator is selected.

20.2.6 Power-Supply-Voltage Detection Circuit Characteristics

Table 20.8 Power-Supply-Voltage Detection Circuit Characteristics

$V_{SS} = 0.0 \text{ V}$, $T_a = -20 \text{ to } +75^\circ\text{C}$, unless otherwise indicated.

Item	Symbol	Test Condition	Values			Unit
			Min.	Typ.	Max.	
Power-supply falling detection voltage	Vint(D)	LVDSEL = 0	3.3	3.7	4.3	V
Power-supply rising detection voltage	Vint(U)	LVDSEL = 0	3.6	4.0	4.5	V
Reset detection voltage 1* ¹	Vreset1	LVDSEL = 0	2.0	2.3	2.7	V
Reset detection voltage 2* ²	Vreset2	LVDSEL = 1	3.0	3.6	4.2	V
Lower-limit voltage of LVDR operation* ³	$V_{LVDRmin}$		1.0	—	—	V
LVD stabilization time	t_{LVDRON}		50	—	—	μs
Current consumption in standby mode	I_{STBY}	LVDE = 1, BGRE = 1 $V_{CC} = 5.0 \text{ V}$	—	—	350	μA

- Notes: 1. This voltage should be used when the falling and rising voltage detection function is used.
 2. Select the low-voltage reset 2 when only the low-voltage detection reset is used.
 3. When the power-supply voltage (V_{CC}) falls below $V_{LVDRmin} = 1.0 \text{ V}$ and then rises, a reset may not occur. Therefore sufficient evaluation is required.

20.2.7 LVDI External Voltage Detection Circuit Characteristics

Table 20.9 LVDI External Voltage Detection Circuit Characteristics

$V_{CC} = 4.5 \text{ to } 5.5 \text{ V}$, $\Delta V_{CC} = 3.0 \text{ to } 5.5 \text{ V}$, $V_{SS} = 0.0 \text{ V}$, $T_a = -20 \text{ to } +75^\circ\text{C}$

Item	Symbol	Test Condition	Values			Unit
			Min.	Typ.	Max.	
ExtD/ExtU input detection voltage	Vextd		0.85	1.15	1.45	V
ExtD/ExtU input voltage range	VextD/U	VextD > VextU	-0.3	—	Lower voltage, either $\Delta V_{CC} + 0.3$ or $V_{CC} + 0.3$	V

20.2.8 Power-On Reset Characteristics

Table 20.10 Power-On Reset Circuit Characteristics

$V_{SS} = 0.0\text{ V}$, $T_a = -20\text{ to }+75^\circ\text{C}$, unless otherwise indicated.

Item	Symbol	Test Condition	Values			Unit
			Min.	Typ.	Max.	
Pull-up resistance of $\overline{\text{RES}}$ pin	R_{RES}		100	150	—	$\text{k}\Omega$
Power-on reset start voltage*	V_{por}		—	—	100	mV

Note: * The power-supply voltage (V_{CC}) must fall below $V_{\text{por}} = 100\text{ mV}$ and then rise after charge of the $\overline{\text{RES}}$ pin is removed completely. In order to remove charge of the $\overline{\text{RES}}$ pin, it is recommended that the diode be placed in the V_{CC} side. If the power-supply voltage (V_{CC}) rises from the point over 100 mV , a power-on reset may not occur.

20.2.9 Flash Memory Characteristics

Table 20.11 Flash Memory Characteristics

$V_{CC} = 3.0\text{ V to }5.5\text{ V}$, $V_{SS} = 0.0\text{ V}$, $T_a = -20^\circ\text{C to }+75^\circ\text{C}$, unless otherwise specified.

Item	Symbol	Test Condition	Values			Unit	
			Min.	Typ.	Max.		
Programming time (per 128 bytes)* ¹ * ² * ⁴	t_p		—	7	200	ms	
Erase time (per block) * ¹ * ³ * ⁶	t_E		—	100	1200	ms	
Reprogramming count	N_{WEC}		1000	10000	—	Times	
Programming	Wait time after SWE bit setting* ¹	x	1	—	—	μs	
	Wait time after PSU bit setting* ¹	y	50	—	—	μs	
	Wait time after P bit setting* ¹ * ⁴	z1	$1 \leq n \leq 6$	28	30	32	μs
		z2	$7 \leq n \leq 1000$	198	200	202	μs
		z3	Additional-programming	8	10	12	μs
	Wait time after P bit clear* ¹	α		5	—	—	μs
	Wait time after PSU bit clear* ¹	β		5	—	—	μs
	Wait time after PV bit setting* ¹	γ		4	—	—	μs
	Wait time after dummy write* ¹	ϵ		2	—	—	μs
	Wait time after PV bit clear* ¹	η		2	—	—	μs
	Wait time after SWE bit clear* ¹	θ		100	—	—	μs
Maximum programming count* ¹ * ⁴ * ⁵	N		—	—	1000	Times	

Item		Symbol	Test Condition	Values			Unit
				Min.	Typ.	Max.	
Erase	Wait time after SWE bit setting* ¹	x		1	—	—	μs
	Wait time after ESU bit setting* ¹	y		100	—	—	μs
	Wait time after E bit setting* ¹ * ⁶	z		10	—	100	ms
	Wait time after E bit clear* ¹	α		10	—	—	μs
	Wait time after ESU bit clear* ¹	β		10	—	—	μs
	Wait time after EV bit setting* ¹	γ		20	—	—	μs
	Wait time after dummy write* ¹	ε		2	—	—	μs
	Wait time after EV bit clear* ¹	η		4	—	—	μs
	Wait time after SWE bit clear* ¹	θ		100	—	—	μs
	Maximum erase count* ¹ * ⁶ * ⁷	N		—	—	120	Times

- Notes:
1. Make the time settings in accordance with the program/erase algorithms.
 2. The programming time for 64 bytes. (Indicates the total time for which the P bit in flash memory control register 1 (FLMCR1) is set. The program-verify time is not included.)
 3. The time required to erase one block. (Indicates the time for which the E bit in flash memory control register 1 (FLMCR1) is set. The erase-verify time is not included.)
 4. Programming time maximum value (t_p (max.)) = wait time after P bit setting (z) × maximum programming count (N)
 5. Set the maximum programming count (N) according to the actual set values of z1, z2, and z3, so that it does not exceed the programming time maximum value (t_p (max.)). The wait time after P bit setting (z1, z2) should be changed as follows according to the value of the programming count (n).
Programming count (n)
 $1 \leq n \leq 6$ z1 = 30 μs
 $7 \leq n \leq 1000$ z2 = 200 μs
 6. Erase time maximum value (t_e (max.)) = wait time after E bit setting (z) × maximum erase count (N)
 7. Set the maximum erase count (N) according to the actual set value of (z), so that it does not exceed the erase time maximum value (t_e (max.)).

20.3 Electrical Characteristics (Masked ROM Version)

20.3.1 Power Supply Voltage and Operating Ranges

1. Supply voltage and external oscillation frequency range

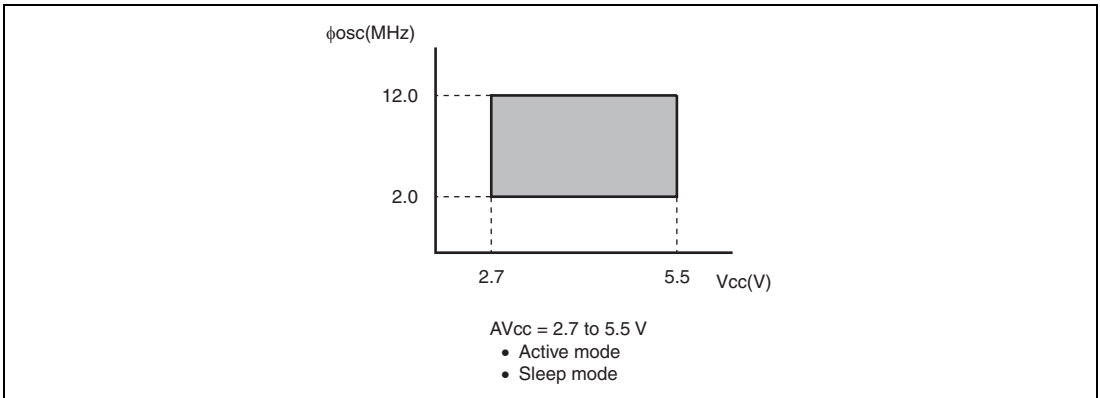

2. Power supply voltage and operating frequency range

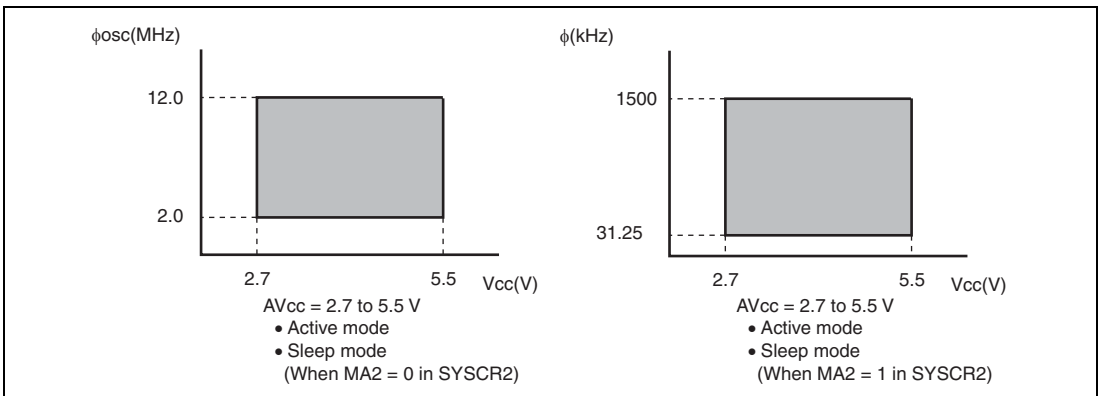

3. Analog power supply voltage and A/D converter accuracy guarantee range

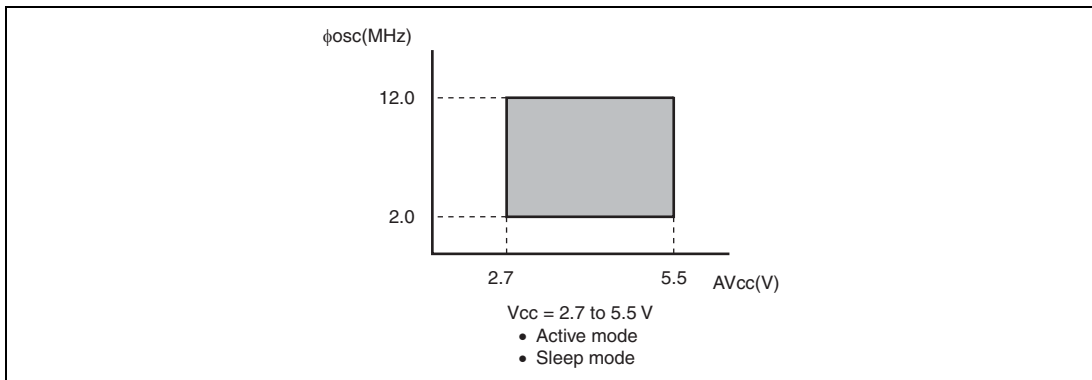

20.3.2 DC Characteristics

Table 20.12 DC Characteristics (1)

$V_{CC} = 2.7\text{ V to }5.5\text{ V}$, $V_{SS} = 0.0\text{ V}$, $T_a = -20^\circ\text{C to }+75^\circ\text{C}$ unless otherwise indicated.

Item	Symbol	Applicable Pins	Test Condition	Values			Unit	Notes
				Min.	Typ.	Max.		
Input high voltage	V_{IH}	\overline{RES} , \overline{NMI} , $\overline{WKP5}$, $\overline{IRQ0}$, $\overline{IRQ3}$, \overline{ADTRG} , \overline{TMRIV} , \overline{TMCIV} , \overline{FTCI} , \overline{FTIOA} to \overline{FTIOD} , $\overline{SCK3}$, \overline{TRGV}	$V_{CC} = 4.0\text{ V to }5.5\text{ V}$	$V_{CC} \times 0.8$	—	$V_{CC} + 0.3$	V	
				$V_{CC} \times 0.9$	—	$V_{CC} + 0.3$	V	
		\overline{RXD} , \overline{SCL} , \overline{SDA} , $\overline{P17}$, $\overline{P14}$, $\overline{P22}$ to $\overline{P20}$, $\overline{P57}$ to $\overline{P55}$, $\overline{P76}$ to $\overline{P74}$, $\overline{P84}$ to $\overline{P80}$, $\overline{PC1}$, $\overline{PC0}$	$V_{CC} = 4.0\text{ V to }5.5\text{ V}$	$V_{CC} \times 0.7$	—	$V_{CC} + 0.3$	V	
				$V_{CC} \times 0.8$	—	$V_{CC} + 0.3$	V	
		$\overline{PB3}$ to $\overline{PB0}$	$AV_{CC} = 4.0\text{ V to }5.5\text{ V}$	$AV_{CC} \times 0.7$	—	$AV_{CC} + 0.3$	V	
			$AV_{CC} = 2.7\text{ V to }5.5\text{ V}$	$AV_{CC} \times 0.8$	—	$AV_{CC} + 0.3$	V	
OSC1	$V_{CC} = 4.0\text{ V to }5.5\text{ V}$	$V_{CC} - 0.5$	—	$V_{CC} + 0.3$	V			
		$V_{CC} - 0.3$		$V_{CC} + 0.3$	V			
Input low voltage	V_{IL}	\overline{RES} , \overline{NMI} , $\overline{WKP5}$, $\overline{IRQ0}$, $\overline{IRQ3}$, \overline{ADTRG} , \overline{TMRIV} , \overline{TMCIV} , \overline{FTCI} , \overline{FTIOA} to \overline{FTIOD} , $\overline{SCK3}$, \overline{TRGV}	$V_{CC} = 4.0\text{ V to }5.5\text{ V}$	-0.3	—	$V_{CC} \times 0.2$	V	
				-0.3	—	$V_{CC} \times 0.1$	V	
		\overline{RXD} , \overline{SCL} , \overline{SDA} , $\overline{P17}$, $\overline{P14}$, $\overline{P22}$ to $\overline{P20}$, $\overline{P57}$ to $\overline{P55}$, $\overline{P76}$ to $\overline{P74}$, $\overline{P84}$ to $\overline{P80}$, $\overline{PC1}$, $\overline{PC0}$	$V_{CC} = 4.0\text{ V to }5.5\text{ V}$	-0.3	—	$V_{CC} \times 0.3$	V	
				-0.3	—	$V_{CC} \times 0.2$	V	
		$\overline{PB3}$ to $\overline{PB0}$	$AV_{CC} = 4.0\text{ V to }5.5\text{ V}$	-0.3	—	$AV_{CC} \times 0.3$	V	
			$AV_{CC} = 2.7\text{ V to }5.5\text{ V}$	-0.3	—	$AV_{CC} \times 0.2$		
OSC1	$V_{CC} = 4.0\text{ V to }5.5\text{ V}$	-0.3	—	0.5	V			
		-0.3	—	0.3	V			

Item	Symbol	Applicable Pins	Test Condition	Values			Unit	Notes
				Min.	Typ.	Max.		
Output high voltage	V_{OH}	P17, P14, P22 to P20, P55, P76 to P74, P84 to P80, PC1, PC0	$V_{CC} = 4.0\text{ V to }5.5\text{ V}$ $-I_{OH} = 4\text{ mA}$	$V_{CC} - 1.0$	—	—	V	
			$-I_{OH} = 0.1\text{ mA}$	$V_{CC} - 0.5$	—	—	V	
		P56, P57	$V_{CC} = 4.0\text{ V to }5.5\text{ V}$ $-I_{OH} = 0.1\text{ mA}$	$V_{CC} - 2.5$	—	—	V	
			$V_{CC} = 2.7\text{ V to }4.0\text{ V}$ $-I_{OH} = 0.1\text{ mA}$	$V_{CC} - 2.2$	—	—	V	
Output low voltage	V_{OL}	P17, P14, P22 to P20, P57 to P55, P76 to P74, PC1, PC0	$V_{CC} = 4.0\text{ V to }5.5\text{ V}$ $I_{OL} = 1.6\text{ mA}$	—	—	0.6	V	
			$I_{OL} = 0.4\text{ mA}$	—	—	0.4	V	
			P84 to P80	$V_{CC} = 4.0\text{ V to }5.5\text{ V}$ $I_{OL} = 20.0\text{ mA}$	—	—	1.5	V
		$V_{CC} = 4.0\text{ V to }5.5\text{ V}$ $I_{OL} = 10.0\text{ mA}$		—	—	1.0	V	
		$V_{CC} = 4.0\text{ V to }5.5\text{ V}$ $I_{OL} = 1.6\text{ mA}$		—	—	0.4	V	
		$I_{OL} = 0.4\text{ mA}$		—	—	0.4	V	
		SCL, SDA	$V_{CC} = 4.0\text{ V to }5.5\text{ V}$ $I_{OL} = 6.0\text{ mA}$	—	—	0.6	V	
			$I_{OL} = 3.0\text{ mA}$	—	—	0.4	V	
				—	—	0.4	V	
		Input/output leakage current	$ I_{IL} $	OSC1, \overline{NMI} , WKP5, $\overline{IRQ0}$, $\overline{IRQ3}$, ADTRG, TRGV, TMRIV, TMCIV, FTCL, FTIOA to FTIOD, RXD, SCK3, SCL, SDA	$V_{IN} = 0.5\text{ V to } (V_{CC} - 0.5\text{ V})$	—	—	1.0
$V_{IN} = 0.5\text{ V to } (V_{CC} - 0.5\text{ V})$	—				—	1.0	μA	
$V_{IN} = 0.5\text{ V to } (AV_{CC} - 0.5\text{ V})$	—				—	1.0	μA	

Item	Symbol	Applicable Pins	Test Condition	Values			Unit	Notes
				Min.	Typ.	Max.		
Pull-up MOS current	$-I_p$	P17, P14, P55	$V_{CC} = 5.0\text{ V}$, $V_{IN} = 0.0\text{ V}$	50.0	—	300.0	μA	
			$V_{CC} = 2.7\text{ V}$, $V_{IN} = 0.0\text{ V}$	—	60.0	—	μA	Reference value
Input capacitance	C_{in}	All input pins except power supply pins	$f = 1\text{ MHz}$, $V_{IN} = 0.0\text{ V}$, $T_a = 25^\circ\text{C}$	—	—	15.0	pF	
Active mode current consumption	I_{OPE1}	V_{CC}	Active mode 1 $V_{CC} = 5.0\text{ V}$, $f_{OSC} = 12\text{ MHz}$	—	12.0	18.0	mA	*
			Active mode 1 $V_{CC} = 2.7\text{ V}$, $f_{OSC} = 12\text{ MHz}$	—	9.6	—	mA	Reference value*
	I_{OPE2}	V_{CC}	Active mode 2 $V_{CC} = 5.0\text{ V}$, $f_{OSC} = 12\text{ MHz}$	—	2.0	2.5	mA	*
			Active mode 2 $V_{CC} = 2.7\text{ V}$, $f_{OSC} = 12\text{ MHz}$	—	1.5	—	mA	Reference value*
Sleep mode current consumption	I_{SLEEP1}	V_{CC}	Sleep mode 1 $V_{CC} = 5.0\text{ V}$, $f_{OSC} = 12\text{ MHz}$	—	7.2	12.0	mA	*
			Sleep mode 1 $V_{CC} = 2.7\text{ V}$, $f_{OSC} = 12\text{ MHz}$	—	6.0	—	mA	Reference value*
	I_{SLEEP2}	V_{CC}	Sleep mode 2 $V_{CC} = 5.0\text{ V}$, $f_{OSC} = 12\text{ MHz}$	—	1.8	2.2	mA	*
			Sleep mode 2 $V_{CC} = 2.7\text{ V}$, $f_{OSC} = 12\text{ MHz}$	—	1.4	—	mA	Reference value*
Subsleep mode current consumption	I_{SUBSP}	V_{CC}	$V_{CC} = 5.0\text{ V}$ LVDE = 0, BGRE = 0	—	—	5.0	μA	*
Standby mode current consumption	I_{STBY}	V_{CC}	LVDE = 0, BGRE = 0	—	—	5.0	μA	*

Item	Symbol	Applicable Pins	Test Condition	Values			Unit	Notes
				Min.	Typ.	Max.		
RAM data retaining voltage	V_{RAM}	V_{CC}		2.0	—	—	V	

Note: * Pin states during current consumption measurement are given below (excluding current in the pull-up MOS transistors and output buffers).

Mode	\overline{RES} Pin	Internal State	Other Pins	Oscillator Pins
Active mode 1	V_{CC}	Operates	V_{CC}	System clock: Crystal or ceramic resonator, and on-chip oscillator
Active mode 2		Operates ($\phi/64$)		
Sleep mode 1	V_{CC}	Only timers operate	V_{CC}	
Sleep mode 2		Only timers operate ($\phi/64$)		
Subsleep mode Standby mode	V_{CC}	CPU and timers both stop	V_{CC}	—

Table 20.12 DC Characteristics (2)

$V_{CC} = 2.7 \text{ V to } 5.5 \text{ V}$, $V_{SS} = 0.0 \text{ V}$, $T_a = -20^\circ\text{C to } +75^\circ\text{C}$, unless otherwise indicated.

Item	Symbol	Application Pins	Test Condition	Values			Unit
				Min.	Typ.	Max.	
Allowable output low current (per pin)	I_{OL}	Output pins except P84 to P80, SCL, and SDA	$V_{CC} = 4.0 \text{ V to } 5.5 \text{ V}$	—	—	2.0	mA
		P84 to P80		—	—	20.0	mA
		Output pins except P84 to P80, SCL, and SDA		—	—	0.5	mA
		P84 to P80		—	—	10.0	mA
		SCL, SDA		—	—	6.0	mA
Allowable output low current (total)	$\sum I_{OL}$	Output pins except P84 to P80, SCL, and SDA	$V_{CC} = 4.0 \text{ V to } 5.5 \text{ V}$	—	—	40.0	mA
		P84 to P80, SCL, and SDA		—	—	80.0	mA
		Output pins except P84 to P80, SCL, and SDA		—	—	20.0	mA
		P84 to P80, SCL, and SDA		—	—	40.0	mA
Allowable output high current (per pin)	I_{OH}	Output pins except P56, P57	$V_{CC} = 4.0 \text{ V to } 5.5 \text{ V}$	—	—	4.0	mA
		P56, P57		—	—	0.2	mA
				$V_{CC} = 4.0 \text{ V to } 5.5 \text{ V}$	—	—	2.0
Allowable output high current (total)	$-\sum I_{OH}$	All output pins	$V_{CC} = 4.0 \text{ V to } 5.5 \text{ V}$	—	—	40.0	mA
				—	—	8.0	mA

20.3.3 AC Characteristics

Table 20.13 AC Characteristics
 $V_{CC} = 2.7\text{ V to }5.5\text{ V}$, $V_{SS} = 0.0\text{ V}$, $T_a = -20^\circ\text{C to }+75^\circ\text{C}$, unless otherwise specified.

Item	Symbol	Applicable Pins	Test Condition	Values			Unit	Reference Figure
				Min.	Typ.	Max.		
System clock oscillation frequency	f_{OSC}	OSC1, OSC2		2.0	—	12.0	MHz	
System clock (ϕ) cycle time	t_{cyc}			1	—	64	t_{OSC}	* Figure 20.1
				—	—	32.0	μs	
Instruction cycle time				2	—	—	t_{cyc}	
Oscillation stabilization time (crystal resonator)	t_{rc}	OSC1, OSC2		—	—	10.0	ms	
Oscillation stabilization time (ceramic resonator)	t_{rc}	OSC1, OSC2		—	—	5.0	ms	
External clock high width	t_{CPH}	OSC1		35.0	—	—	ns	Figure 20.1
External clock low width	t_{CPL}	OSC1		35.0	—	—	ns	
External clock rise time	t_{CPr}	OSC1		—	—	15.0	ns	
External clock fall time	t_{CPf}	OSC1		—	—	15.0	ns	
RES pin low width*	t_{REL}	$\overline{\text{RES}}$		2500	—	—	ns	Figure 20.2
NMI pin high width	$t_{IH\text{NMI}}$	$\overline{\text{NMI}}$		1500	—	—	ns	Figure 20.3
NMI pin low width	$t_{IL\text{NMI}}$	$\overline{\text{NMI}}$		1500	—	—	ns	
Input pin high width	t_{IH}	$\overline{\text{IRQ0}}$, $\overline{\text{IRQ3}}$, $\overline{\text{WKP5}}$, $\overline{\text{TMCIV}}$, $\overline{\text{TMRIV}}$, $\overline{\text{TRGV}}$, $\overline{\text{ADTRG}}$, $\overline{\text{FTCI}}$, $\overline{\text{FTIOA}}$ to $\overline{\text{FTIOD}}$		2	—	—	t_{cyc}	Figure 20.3

Note: * Except when power-on reset circuit is used.

Item	Symbol	Applicable Pins	Test Condition	Values			Unit	Reference Figure
				Min.	Typ.	Max.		
Input pin low width	t_{IL}	IRQ0, IRQ3, WKP5, TMCIV, TMRIV, TRGV, ADTRG, FTCL, FTIOA to FTIOD		2	—	—	t_{cyc}	Figure 20.3
On-chip oscillator oscillation frequency	f_{RC}		$V_{CC} = 4.0\text{ V to }5.5\text{ V}$ FSEL = 0, VCLSEL = 0	7.6	8.0	8.4	MHz	
			$V_{CC} = 4.0\text{ V to }5.5\text{ V}$ FSEL = 1, VCLSEL = 0	9.4	10.0	10.6		

Notes: * Determined by MA2 to MA0 in system control register 2 (SYSCR2).

Table 20.14 I²C Bus Interface Timing

$V_{CC} = 2.7$ to 5.5 V, $V_{SS} = 0.0$ V, $T_a = -20$ to $+75^{\circ}\text{C}$, unless otherwise indicated.

Item	Symbol	Applicable Pins	Test Condition	Values			Unit	Reference Figure
				Min.	Typ.	Max.		
SCL input cycle time	t_{SCL}			$12t_{cyc} + 600$	—	—	ns	Figure 20.4
SCL input high pulse width	t_{SCLH}			$3t_{cyc} + 300$	—	—	ns	
SCL input low pulse width	t_{SCLL}			$5t_{cyc} + 300$	—	—	ns	
SCL and SDA input fall time	t_{Sf}			—	—	300	ns	
SCL and SDA input spike pulse removal time	t_{SP}			—	—	$1t_{cyc}$	ns	
SDA input bus-free time	t_{BUF}			$5t_{cyc}$	—	—	ns	
Start condition input hold time	t_{STAH}			$3t_{cyc}$	—	—	ns	
Retransmission start condition input setup time	t_{STAS}			$3t_{cyc}$	—	—	ns	
Setup time for stop condition input	t_{STOS}			$3t_{cyc}$	—	—	ns	
Data input setup time	t_{SDAS}			$1t_{cyc} + 20$	—	—	ns	
Data input hold time	t_{SDAH}			0	—	—	ns	
Capacitive load of SCL and SDA	C_b			0	—	400	pF	
SCL and SDA output fall time	t_{Sf}	$V_{CC} = 4.0$ to 5.5 V	—	—	—	250	ns	
			—	—	—	300	ns	

Table 20.15 Serial Interface (SCI3) Timing

$V_{CC} = 2.7\text{ V to }5.5\text{ V}$, $V_{SS} = 0.0\text{ V}$, $T_a = -20^{\circ}\text{C to }+75^{\circ}\text{C}$, unless otherwise specified.

Item	Symbol	Applicable Pins	Test Condition	Values			Unit	Reference Figure
				Min.	Typ.	Max.		
Input clock cycle	Asynchronous	t_{scyc}	SCK3	4	—	—	t_{cyc}	Figure 20.5
	Clocked synchronous			6	—	—	t_{cyc}	
Input clock pulse width	t_{SCKW}	SCK3		0.4	—	0.6	t_{scyc}	
Transmit data delay time (clocked synchronous)	t_{TXD}	TXD		—	—	1	t_{cyc}	Figure 20.6
Receive data setup time (clocked synchronous)	t_{RXS}	RXD		83.3	—	—	ns	
Receive data hold time (clocked synchronous)	t_{RXH}	RXD		83.3	—	—	ns	

20.3.4 A/D Converter Characteristics

Table 20.16 A/D Converter Characteristics

$V_{CC} = 2.7\text{ V to }5.5\text{ V}$, $V_{SS} = 0.0\text{ V}$, $T_a = -20^\circ\text{C to }+75^\circ\text{C}$, unless otherwise specified.

Item	Symbol	Applicable Pins	Test Condition	Values			Unit	Notes
				Min.	Typ.	Max.		
Analog power supply voltage	AV_{CC}	AV_{CC}		2.7	V_{CC}	5.5	V	*1
Analog input voltage	AV_{IN}	AN3 to AN0		$V_{SS} - 0.3$	—	$AV_{CC} + 0.3$	V	
Analog power supply current	AI_{OPE}	AV_{CC}	$AV_{CC} = 5.0\text{ V}$ $f_{OSC} = 12\text{ MHz}$	—	—	2.0	mA	
	AI_{STOP1}	AV_{CC}		—	50	—	μA	*2 Reference value
	AI_{STOP2}	AV_{CC}		—	—	5.0	μA	*3
Analog input capacitance	C_{AIN}	AN3 to AN0		—	—	30.0	pF	
Allowable signal source impedance	R_{AIN}	AN3 to AN0		—	—	5.0	k Ω	
Resolution (data length)				10	10	10	bit	
Conversion time (single mode)			$AV_{CC} = 2.7\text{ V to }5.5\text{ V}$	134	—	—	t_{cyc}	
Nonlinearity error				—	—	± 7.5	LSB	
Offset error				—	—	± 7.5	LSB	
Full-scale error				—	—	± 7.5	LSB	
Quantization error				—	—	± 0.5	LSB	
Absolute accuracy				—	—	± 8.0	LSB	
Conversion time (single mode)			$AV_{CC} = 4.0\text{ V to }5.5\text{ V}$	70	—	—	t_{cyc}	
Nonlinearity error				—	—	± 7.5	LSB	
Offset error				—	—	± 7.5	LSB	
Full-scale error				—	—	± 7.5	LSB	
Quantization error				—	—	± 0.5	LSB	
Absolute accuracy				—	—	± 8.0	LSB	

Item	Symbol	Applicable Pins	Test Condition	Values			Unit	Notes
				Min.	Typ.	Max.		
Conversion time (single mode)			$AV_{CC} = 4.0\text{ V}$ to 5.5 V	134	—	—	t_{cyc}	
Nonlinearity error				—	—	±3.5	LSB	
Offset error				—	—	±3.5	LSB	
Full-scale error				—	—	±3.5	LSB	
Quantization error				—	—	±0.5	LSB	
Absolute accuracy				—	—	±4.0	LSB	

- Notes:
1. Set $AV_{CC} = V_{CC}$ when the A/D converter is not used.
 2. AI_{STOP1} is the current in active and sleep modes while the A/D converter is idle.
 3. AI_{STOP2} is the current at reset and in standby and subsleep modes while the A/D converter is idle.

20.3.5 Watchdog Timer Characteristics

Table 20.17 Watchdog Timer Characteristics

$V_{CC} = 2.7\text{ V}$ to 5.5 V, $V_{SS} = 0.0\text{ V}$, $T_a = -20^\circ\text{C}$ to $+75^\circ\text{C}$, unless otherwise specified.

Item	Symbol	Applicable Pins	Test Condition	Values			Unit	Notes
				Min.	Typ.	Max.		
Internal oscillator overflow time	t_{OVF}			0.2	0.4	—	s	*

Note: * Shows the time to count from 0 to 255, at which point an internal reset is generated, when the internal oscillator is selected.

20.3.6 Power-Supply-Voltage Detection Circuit Characteristics

Table 20.18 Power-Supply-Voltage Detection Circuit Characteristics

$V_{SS} = 0.0 \text{ V}$, $T_a = -20$ to $+75^\circ\text{C}$, unless otherwise indicated.

Item	Symbol	Test Condition	Values			Unit
			Min.	Typ.	Max.	
Power-supply falling detection voltage	Vint(D)	LVDSEL = 0	3.3	3.7	4.3	V
Power-supply rising detection voltage	Vint(U)	LVDSEL = 0	3.6	4.0	4.5	V
Reset detection voltage 1* ¹	Vreset1	LVDSEL = 0	2.0	2.3	2.7	V
Reset detection voltage 2* ²	Vreset2	LVDSEL = 1	3.0	3.6	4.2	V
Lower-limit voltage of LVDR operation* ³	$V_{LVDRmin}$		1.0	—	—	V
LVD stabilization time	t_{LVDRON}		50	—	—	μs
Current consumption in standby mode	I_{STBY}	LVDE = 1, BGRE = 1 $V_{CC} = 5.0 \text{ V}$	—	—	350	μA

- Notes: 1. This voltage should be used when the falling and rising voltage detection function is used.
 2. Select the low-voltage reset 2 when only the low-voltage detection reset is used.
 3. When the power-supply voltage (V_{CC}) falls below $V_{LVDRmin} = 1.0 \text{ V}$ and then rises, a reset may not occur. Therefore sufficient evaluation is required.

20.3.7 LVDI External Voltage Detection Circuit Characteristics

Table 20.19 LVDI External Voltage Detection Circuit Characteristics

$V_{CC} = 4.5$ to 5.5 V , $AV_{CC} = 2.7$ to 5.5 V , $V_{SS} = 0.0 \text{ V}$, $T_a = -20$ to $+75^\circ\text{C}$

Item	Symbol	Test Condition	Values			Unit
			Min.	Typ.	Max.	
ExtD/ExtU input detection voltage	Vexd		0.85	1.15	1.45	V
ExtD/ExtU input voltage range	VextD/U	VextD > VextU	-0.3	—	Lower voltage, either $AV_{CC} + 0.3$ or $V_{CC} + 0.3$	V

20.3.8 Power-On Reset Characteristics

Table 20.20 Power-On Reset Circuit Characteristics

$V_{SS} = 0.0 \text{ V}$, $T_a = -20 \text{ to } +75^\circ\text{C}$, unless otherwise indicated.

Item	Symbol	Test Condition	Values			Unit
			Min.	Typ.	Max.	
Pull-up resistance of $\overline{\text{RES}}$ pin	R_{RES}		100	150	—	$\text{k}\Omega$
Power-on reset start voltage*	V_{por}		—	—	100	mV

Note: * The power-supply voltage (V_{CC}) must fall below $V_{\text{por}} = 100 \text{ mV}$ and then rise after charge of the $\overline{\text{RES}}$ pin is removed completely. In order to remove charge of the $\overline{\text{RES}}$ pin, it is recommended that the diode be placed in the V_{CC} side. If the power-supply voltage (V_{CC}) rises from the point over 100 mV , a power-on reset may not occur.

20.4 Operation Timing

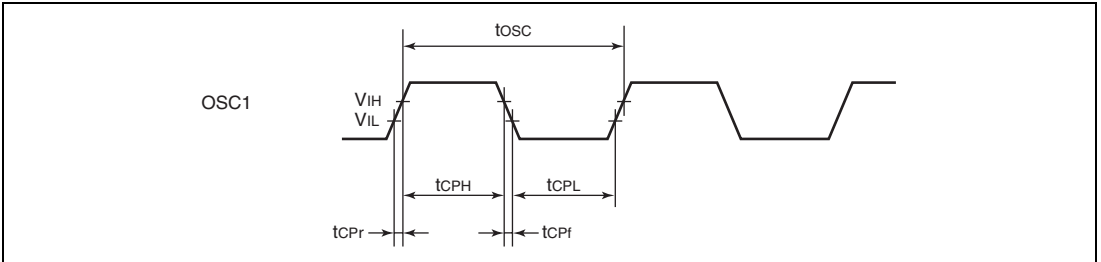

Figure 20.1 System Clock Input Timing

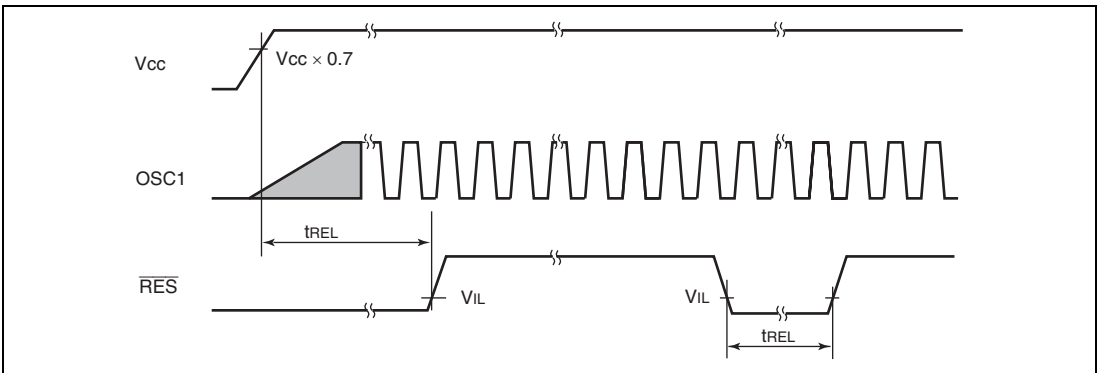

Figure 20.2 $\overline{\text{RES}}$ Low Width Timing

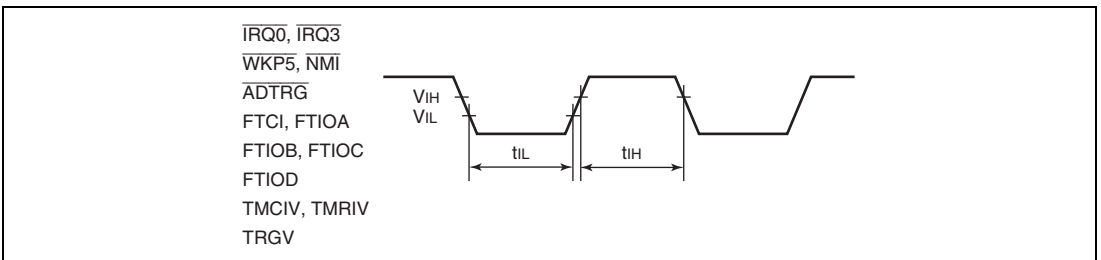

Figure 20.3 Input Timing

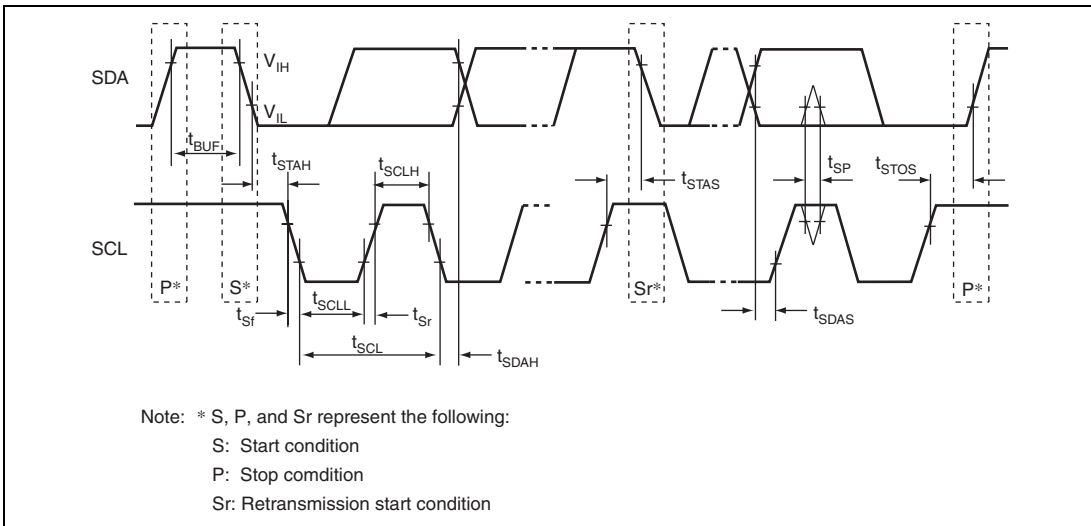

Figure 20.4 I²C Bus Interface Input/Output Timing

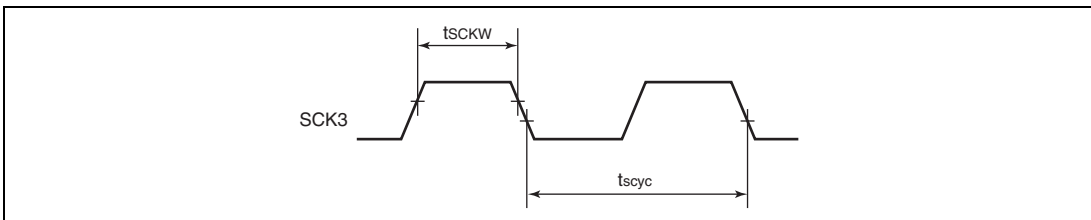

Figure 20.5 SCK3 Input Clock Timing

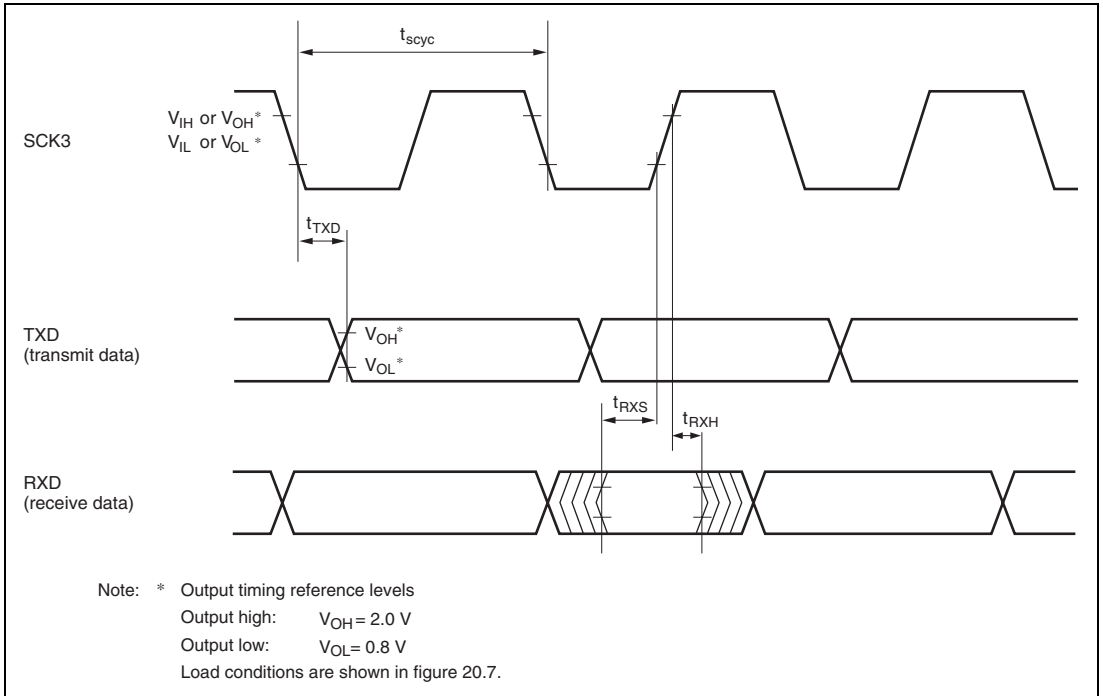

Figure 20.6 SCI3 Input/Output Timing in Clocked Synchronous Mode

20.5 Output Load Condition

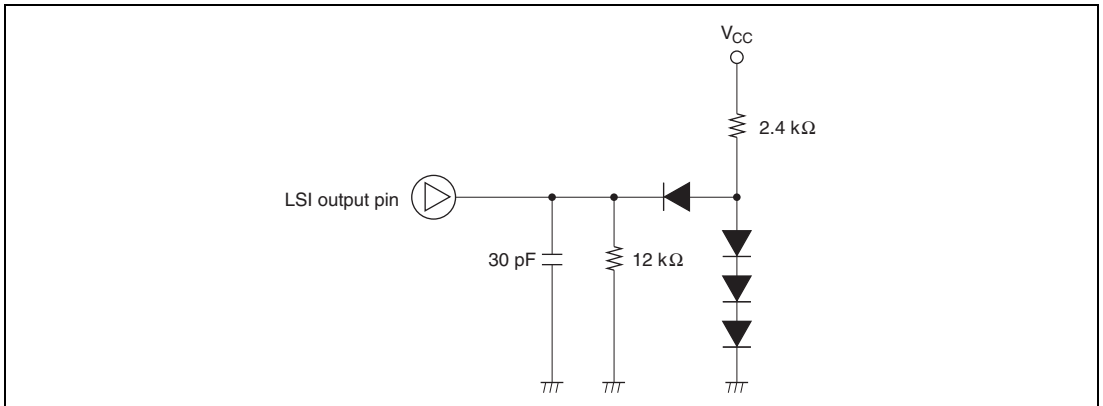

Figure 20.7 Output Load Circuit

Appendix A Instruction Set

A.1 Instruction List

- Operand Notation

Symbol	Description
Rd	General (destination*) register
Rs	General (source*) register
Rn	General register*
ERd	General destination register (address register or 32-bit register)
ERs	General source register (address register or 32-bit register)
ERn	General register (32-bit register)
(EAd)	Destination operand
(EAs)	Source operand
PC	Program counter
SP	Stack pointer
CCR	Condition-code register
N	N (negative) flag in CCR
Z	Z (zero) flag in CCR
V	V (overflow) flag in CCR
C	C (carry) flag in CCR
disp	Displacement
→	Transfer from the operand on the left to the operand on the right, or transition from the state on the left to the state on the right
+	Addition of the operands on both sides
–	Subtraction of the operand on the right from the operand on the left
×	Multiplication of the operands on both sides
÷	Division of the operand on the left by the operand on the right
^	Logical AND of the operands on both sides
∨	Logical OR of the operands on both sides
⊕	Logical exclusive OR of the operands on both sides
¬	NOT (logical complement)

Symbol **Description**

(), < > Contents of operand

Note: General registers include 8-bit registers (R0H to R7H and R0L to R7L) and 16-bit registers (R0 to R7 and E0 to E7).

- Condition Code Notation

Symbol **Description**

↕ Changed according to execution result

* Undetermined (no guaranteed value)

0 Cleared to 0

1 Set to 1

— Not affected by execution of the instruction

Δ Varies depending on conditions, described in notes

Mnemonic	Operand Size	Addressing Mode and Instruction Length (bytes)								Operation	Condition Code						No. of States ^{*1}		
		#xx	Rn	@ERn	@ (d, ERn)	@-ERn/@ERn+	@aa	@ (d, PC)	@@aa			I	H	N	Z	V	C	Normal	Advanced
MOV	MOV.W Rs, @-ERd	W				2				ERd32-2 → ERd32 Rs16 → @ERd	—	—	↑	↓	0	—	6		
	MOV.W Rs, @aa:16	W				4				Rs16 → @aa:16	—	—	↑	↓	0	—	6		
	MOV.W Rs, @aa:24	W				6				Rs16 → @aa:24	—	—	↑	↓	0	—	8		
	MOV.L #xx:32, Rd	L	6							#xx:32 → Rd32	—	—	↑	↓	0	—	6		
	MOV.L ERs, ERd	L		2						ERs32 → ERd32	—	—	↑	↓	0	—	2		
	MOV.L @ERs, ERd	L			4					@ERs → ERd32	—	—	↑	↓	0	—	8		
	MOV.L @ (d:16, ERs), ERd	L				6				@ (d:16, ERs) → ERd32	—	—	↑	↓	0	—	10		
	MOV.L @ (d:24, ERs), ERd	L				10				@ (d:24, ERs) → ERd32	—	—	↑	↓	0	—	14		
	MOV.L @ERs+, ERd	L				4				@ERs → ERd32 ERs32+4 → ERs32	—	—	↑	↓	0	—	10		
	MOV.L @aa:16, ERd	L				6				@aa:16 → ERd32	—	—	↑	↓	0	—	10		
	MOV.L @aa:24, ERd	L				8				@aa:24 → ERd32	—	—	↑	↓	0	—	12		
	MOV.L ERs, @ERd	L			4					ERs32 → @ERd	—	—	↑	↓	0	—	8		
	MOV.L ERs, @ (d:16, ERd)	L				6				ERs32 → @ (d:16, ERd)	—	—	↑	↓	0	—	10		
	MOV.L ERs, @ (d:24, ERd)	L				10				ERs32 → @ (d:24, ERd)	—	—	↑	↓	0	—	14		
	MOV.L ERs, @-ERd	L				4				ERd32-4 → ERd32 ERs32 → @ERd	—	—	↑	↓	0	—	10		
MOV.L ERs, @aa:16	L				6				ERs32 → @aa:16	—	—	↑	↓	0	—	10			
MOV.L ERs, @aa:24	L				8				ERs32 → @aa:24	—	—	↑	↓	0	—	12			
POP	POP.W Rn	W						2	@SP → Rn16 SP+2 → SP	—	—	↑	↓	0	—	6			
	POP.L ERn	L						4	@SP → ERn32 SP+4 → SP	—	—	↑	↓	0	—	10			
PUSH	PUSH.W Rn	W						2	SP-2 → SP Rn16 → @SP	—	—	↑	↓	0	—	6			
	PUSH.L ERn	L						4	SP-4 → SP ERn32 → @SP	—	—	↑	↓	0	—	10			
MOVFPE	MOVFPE @aa:16, Rd	B					4		Cannot be used in this LSI	Cannot be used in this LSI									
MOVTPPE	MOVTPPE Rs, @aa:16	B					4		Cannot be used in this LSI	Cannot be used in this LSI									

- Arithmetic instructions

	Mnemonic	Operand Size	Addressing Mode and Instruction Length (bytes)								Operation	Condition Code						No. of States ^{*1}		
			#xx	Rn	@ERn	@ (d, ERn)	@-ERn/@ERn+	@aa	@ (d, PC)	@ @aa			I	H	N	Z	V	C	Normal	Advanced
ADD	ADD.B #xx:8, Rd	B	2																2	
	ADD.B Rs, Rd	B	2																2	
	ADD.W #xx:16, Rd	W	4									(1)	↓	↓	↓	↓			4	
	ADD.W Rs, Rd	W	2									(1)	↓	↓	↓	↓			2	
	ADD.L #xx:32, ERd	L	6									(2)	↓	↓	↓	↓			6	
	ADD.L ERs, ERd	L	2								(2)	↓	↓	↓	↓			2		
ADDX	ADDX.B #xx:8, Rd	B	2									↓	↓	(3)	↓	↓		2		
	ADDX.B Rs, Rd	B	2									↓	↓	(3)	↓	↓		2		
ADDS	ADDS.L #1, ERd	L	2									—	—	—	—	—		2		
	ADDS.L #2, ERd	L	2									—	—	—	—	—		2		
	ADDS.L #4, ERd	L	2									—	—	—	—	—		2		
INC	INC.B Rd	B	2									—	—	↑	↑	↑		2		
	INC.W #1, Rd	W	2									—	—	↑	↑	↑		2		
	INC.W #2, Rd	W	2									—	—	↑	↑	↑		2		
	INC.L #1, ERd	L	2									—	—	↑	↑	↑		2		
	INC.L #2, ERd	L	2									—	—	↑	↑	↑		2		
DAA	DAA Rd	B	2									—	*	↓	↓	*	↓	2		
SUB	SUB.B Rs, Rd	B	2									—	↓	↓	↓	↓	↓		2	
	SUB.W #xx:16, Rd	W	4									(1)	↓	↓	↓	↓		4		
	SUB.W Rs, Rd	W	2									(1)	↓	↓	↓	↓		2		
	SUB.L #xx:32, ERd	L	6									(2)	↓	↓	↓	↓		6		
	SUB.L ERs, ERd	L	2									(2)	↓	↓	↓	↓		2		
SUBX	SUBX.B #xx:8, Rd	B	2									—	↓	↓	(3)	↓	↓	2		
	SUBX.B Rs, Rd	B	2									—	↓	↓	(3)	↓	↓	2		
SUBS	SUBS.L #1, ERd	L	2									—	—	—	—	—		2		
	SUBS.L #2, ERd	L	2									—	—	—	—	—		2		
	SUBS.L #4, ERd	L	2									—	—	—	—	—		2		
DEC	DEC.B Rd	B	2									—	—	↑	↑	↑		2		
	DEC.W #1, Rd	W	2									—	—	↑	↑	↑		2		
	DEC.W #2, Rd	W	2									—	—	↑	↑	↑		2		

Mnemonic		Operand Size	Addressing Mode and Instruction Length (bytes)							Operation	Condition Code						No. of States ^{*1}		
			#xx	Rn	@ERn	@ (d, ERn)	@ -ERn/ @ERn+	@aa	@ (d, PC)		@ @aa	I	H	N	Z	V	C	Normal	Advanced
DEC	DEC.L #1, ERd	L	2														2		
	DEC.L #2, ERd	L	2														2		
DAS	DAS.Rd	B	2								*			*			2		
MULXU	MULXU. B Rs, Rd	B	2														14		
	MULXU. W Rs, ERd	W	2														22		
MULXS	MULXS. B Rs, Rd	B	4														16		
	MULXS. W Rs, ERd	W	4														24		
DIVXU	DIVXU. B Rs, Rd	B	2									(6)	(7)				14		
	DIVXU. W Rs, ERd	W	2									(6)	(7)				22		
DIVXS	DIVXS. B Rs, Rd	B	4									(8)	(7)				16		
	DIVXS. W Rs, ERd	W	4									(8)	(7)				24		
CMP	CMP.B #xx:8, Rd	B	2														2		
	CMP.B Rs, Rd	B	2														2		
	CMP.W #xx:16, Rd	W	4								(1)						4		
	CMP.W Rs, Rd	W	2								(1)						2		
	CMP.L #xx:32, ERd	L	6								(2)						4		
	CMP.L ERs, ERd	L	2								(2)						2		

- Logic instructions

Mnemonic		Operand Size	Addressing Mode and Instruction Length (bytes)								Operation	Condition Code						No. of States ^{*1}		
			#xx	Rn	@ERn	@ (d, ERn)	@-ERn/@ERn+	@aa	@ (d, PC)	@@aa			I	H	N	Z	V	C	Normal	Advanced
AND	AND.B #xx:8, Rd	B	2															2		
	AND.B Rs, Rd	B	2															2		
	AND.W #xx:16, Rd	W	4															4		
	AND.W Rs, Rd	W	2															2		
	AND.L #xx:32, ERd	L	6															6		
	AND.L ERs, ERd	L	4															4		
OR	OR.B #xx:8, Rd	B	2															2		
	OR.B Rs, Rd	B	2															2		
	OR.W #xx:16, Rd	W	4															4		
	OR.W Rs, Rd	W	2															2		
	OR.L #xx:32, ERd	L	6															6		
	OR.L ERs, ERd	L	4															4		
XOR	XOR.B #xx:8, Rd	B	2															2		
	XOR.B Rs, Rd	B	2															2		
	XOR.W #xx:16, Rd	W	4															4		
	XOR.W Rs, Rd	W	2															2		
	XOR.L #xx:32, ERd	L	6															6		
XOR.L ERs, ERd	L	4															4			
NOT	NOT.B Rd	B	2															2		
	NOT.W Rd	W	2															2		
	NOT.L ERd	L	2															2		

- Bit manipulation instructions

Mnemonic		Addressing Mode and Instruction Length (bytes)								Operation	Condition Code						No. of States ^{*1}															
		Operand Size	#xx	Rn	@ERn	@ (d, ERn)	@-ERn/@ERn+	@aa	@ (d, PC)		@aa		I	H	N	Z	V	C	Normal	Advanced												
BSET	BSET #xx:3, Rd	B	2																	(#xx:3 of Rd8) ← 1	—	—	—	—	—	—	—	—	—	—	—	2
	BSET #xx:3, @ERd	B		4																	(#xx:3 of @ERd) ← 1	—	—	—	—	—	—	—	—	—	—	8
	BSET #xx:3, @aa:8	B						4													(#xx:3 of @aa:8) ← 1	—	—	—	—	—	—	—	—	—	—	8
	BSET Rn, Rd	B	2																		(Rn8 of Rd8) ← 1	—	—	—	—	—	—	—	—	—	—	2
	BSET Rn, @ERd	B		4																	(Rn8 of @ERd) ← 1	—	—	—	—	—	—	—	—	—	—	8
	BSET Rn, @aa:8	B						4													(Rn8 of @aa:8) ← 1	—	—	—	—	—	—	—	—	—	—	8
BCLR	BCLR #xx:3, Rd	B	2																		(#xx:3 of Rd8) ← 0	—	—	—	—	—	—	—	—	—	—	2
	BCLR #xx:3, @ERd	B		4																	(#xx:3 of @ERd) ← 0	—	—	—	—	—	—	—	—	—	—	8
	BCLR #xx:3, @aa:8	B					4														(#xx:3 of @aa:8) ← 0	—	—	—	—	—	—	—	—	—	—	8
	BCLR Rn, Rd	B	2																		(Rn8 of Rd8) ← 0	—	—	—	—	—	—	—	—	—	—	2
	BCLR Rn, @ERd	B		4																	(Rn8 of @ERd) ← 0	—	—	—	—	—	—	—	—	—	—	8
	BCLR Rn, @aa:8	B					4														(Rn8 of @aa:8) ← 0	—	—	—	—	—	—	—	—	—	—	8
BNOT	BNOT #xx:3, Rd	B	2																		(#xx:3 of Rd8) ← ¬ (#xx:3 of Rd8)	—	—	—	—	—	—	—	—	—	—	2
	BNOT #xx:3, @ERd	B		4																	(#xx:3 of @ERd) ← ¬ (#xx:3 of @ERd)	—	—	—	—	—	—	—	—	—	—	8
	BNOT #xx:3, @aa:8	B					4														(#xx:3 of @aa:8) ← ¬ (#xx:3 of @aa:8)	—	—	—	—	—	—	—	—	—	—	8
	BNOT Rn, Rd	B	2																		(Rn8 of Rd8) ← ¬ (Rn8 of Rd8)	—	—	—	—	—	—	—	—	—	—	2
	BNOT Rn, @ERd	B		4																	(Rn8 of @ERd) ← ¬ (Rn8 of @ERd)	—	—	—	—	—	—	—	—	—	—	8
	BNOT Rn, @aa:8	B					4														(Rn8 of @aa:8) ← ¬ (Rn8 of @aa:8)	—	—	—	—	—	—	—	—	—	—	8
BTST	BTST #xx:3, Rd	B	2																		¬ (#xx:3 of Rd8) → Z	—	—	—	↑	—	—	—	—	—	—	2
	BTST #xx:3, @ERd	B		4																	¬ (#xx:3 of @ERd) → Z	—	—	—	↑	—	—	—	—	—	—	6
	BTST #xx:3, @aa:8	B					4														¬ (#xx:3 of @aa:8) → Z	—	—	—	↑	—	—	—	—	—	—	6
	BTST Rn, Rd	B	2																		¬ (Rn8 of @Rd8) → Z	—	—	—	↑	—	—	—	—	—	—	2
	BTST Rn, @ERd	B		4																	¬ (Rn8 of @ERd) → Z	—	—	—	↑	—	—	—	—	—	—	6
	BTST Rn, @aa:8	B					4														¬ (Rn8 of @aa:8) → Z	—	—	—	↑	—	—	—	—	—	—	6
BLD	BLD #xx:3, Rd	B	2																		(#xx:3 of Rd8) → C	—	—	—	—	—	—	—	↑	—	—	2

Mnemonic		Addressing Mode and Instruction Length (bytes)								Operation	Condition Code						No. of States ^{*1}			
		Operand Size	#xx	Rn	@ERn	@ (d, ERn)	@-ERn/@ERn+	@aa	@ (d, PC)		@aa		I	H	N	Z	V	C	Normal	Advanced
BLD	BLD #xx:3, @ERd	B		4												↑	6			
	BLD #xx:3, @aa:8	B					4									↓	6			
BILD	BILD #xx:3, Rd	B	2													↑	2			
	BILD #xx:3, @ERd	B		4												↑	6			
	BILD #xx:3, @aa:8	B					4									↓	6			
BST	BST #xx:3, Rd	B	2														2			
	BST #xx:3, @ERd	B		4													8			
BIST	BST #xx:3, @aa:8	B					4										8			
	BIST #xx:3, Rd	B	2														2			
	BIST #xx:3, @ERd	B		4													8			
	BIST #xx:3, @aa:8	B					4										8			
BAND	BAND #xx:3, Rd	B	2													↑	2			
	BAND #xx:3, @ERd	B		4												↓	6			
BIAND	BAND #xx:3, @aa:8	B					4									↓	6			
	BIAND #xx:3, Rd	B	2													↓	2			
	BIAND #xx:3, @ERd	B		4												↓	6			
	BIAND #xx:3, @aa:8	B					4									↓	6			
BOR	BOR #xx:3, Rd	B	2														2			
	BOR #xx:3, @ERd	B		4													6			
	BOR #xx:3, @aa:8	B					4										6			
BIOR	BIOR #xx:3, Rd	B	2														2			
	BIOR #xx:3, @ERd	B		4													6			
	BIOR #xx:3, @aa:8	B					4										6			
BXOR	BXOR #xx:3, Rd	B	2														2			
	BXOR #xx:3, @ERd	B		4													6			
	BXOR #xx:3, @aa:8	B					4										6			
BIXOR	BIXOR #xx:3, Rd	B	2														2			
	BIXOR #xx:3, @ERd	B		4													6			
	BIXOR #xx:3, @aa:8	B					4										6			

- Branching instructions

Mnemonic		Operand Size	Addressing Mode and Instruction Length (bytes)								Operation	Condition Code						No. of States ^{*1}				
			#xx	Rn	@ ERn	@ (d, ERn)	@ -ERn/@ERn+	@ aa	@ (d, PC)	@ @aa		I	Branch Condition	I	H	N	Z	V	C	Normal	Advanced	
Bcc	BRA d:8 (BT d:8)	—								2	If condition is true then PC ← PC+d else next;	Always	—	—	—	—	—	—	—	4		
	BRA d:16 (BT d:16)	—								4		6										
	BRN d:8 (BF d:8)	—								2		Never	—	—	—	—	—	—	—	—	4	
	BRN d:16 (BF d:16)	—										4	6									
	BHI d:8	—										2	C/Z = 0	—	—	—	—	—	—	—	—	4
	BHI d:16	—										4	6									
	BLS d:8	—										2	C/Z = 1	—	—	—	—	—	—	—	—	4
	BLS d:16	—										4	6									
	BCC d:8 (BHS d:8)	—										2	C = 0	—	—	—	—	—	—	—	—	4
	BCC d:16 (BHS d:16)	—										4	6									
	BCS d:8 (BLO d:8)	—										2	C = 1	—	—	—	—	—	—	—	—	4
	BCS d:16 (BLO d:16)	—										4	6									
	BNE d:8	—										2	Z = 0	—	—	—	—	—	—	—	—	4
	BNE d:16	—										4	6									
	BEQ d:8	—										2	Z = 1	—	—	—	—	—	—	—	—	4
	BEQ d:16	—										4	6									
	BVC d:8	—										2	V = 0	—	—	—	—	—	—	—	—	4
	BVC d:16	—										4	6									
	BVS d:8	—										2	V = 1	—	—	—	—	—	—	—	—	4
	BVS d:16	—										4	6									
	BPL d:8	—										2	N = 0	—	—	—	—	—	—	—	—	4
	BPL d:16	—										4	6									
	BMI d:8	—										2	N = 1	—	—	—	—	—	—	—	—	4
	BMI d:16	—										4	6									
	BGE d:8	—										2	N⊕V = 0	—	—	—	—	—	—	—	—	4
	BGE d:16	—										4	6									
	BLT d:8	—										2	N⊕V = 1	—	—	—	—	—	—	—	—	4
	BLT d:16	—										4	6									
	BGT d:8	—										2	Z/(N⊕V) = 0	—	—	—	—	—	—	—	—	4
	BGT d:16	—										4	6									
	BLE d:8	—										2	Z/(N⊕V) = 1	—	—	—	—	—	—	—	—	4
	BLE d:16	—										4	6									

- System control instructions

Mnemonic		Operand Size	Addressing Mode and Instruction Length (bytes)								Operation	Condition Code						No. of States ^{*1}			
			#xx	Rn	@ERn	@ (d, ERn)	@-ERn/@ERn+	@aa	@ (d, PC)	@aa			I	H	N	Z	V	C	Normal	Advanced	
TRAPA	TRAPA #x:2	—									2	PC → @-SP CCR → @-SP <vector> → PC	1	—	—	—	—	—	—	14	16
RTE	RTE	—										CCR ← @SP+ PC ← @SP+	↑	↑	↑	↑	↑	↑	↑	10	
SLEEP	SLEEP	—										Transition to power-down state	—	—	—	—	—	—	—	2	
LDC	LDC #xx:8, CCR	B	2									#xx:8 → CCR	↑	↑	↑	↑	↑	↑	↑	2	
	LDC Rs, CCR	B		2								Rs8 → CCR	↑	↑	↑	↑	↑	↑	↑	2	
	LDC @ERs, CCR	W			4							@ERs → CCR	↑	↑	↑	↑	↑	↑	↑	6	
	LDC @ (d:16, ERs), CCR	W				6						@ (d:16, ERs) → CCR	↑	↑	↑	↑	↑	↑	↑	8	
	LDC @ (d:24, ERs), CCR	W					10					@ (d:24, ERs) → CCR	↑	↑	↑	↑	↑	↑	↑	12	
	LDC @ERs+, CCR	W						4				@ERs → CCR ERs32+2 → ERs32	↑	↑	↑	↑	↑	↑	↑	8	
	LDC @aa:16, CCR	W							6			@aa:16 → CCR	↑	↑	↑	↑	↑	↑	↑	8	
	LDC @aa:24, CCR	W								8		@aa:24 → CCR	↑	↑	↑	↑	↑	↑	↑	10	
STC	STC CCR, Rd	B		2								CCR → Rd8	—	—	—	—	—	—	—	2	
	STC CCR, @ERd	W			4							CCR → @ERd	—	—	—	—	—	—	—	6	
	STC CCR, @ (d:16, ERd)	W				6						CCR → @ (d:16, ERd)	—	—	—	—	—	—	—	8	
	STC CCR, @ (d:24, ERd)	W					10					CCR → @ (d:24, ERd)	—	—	—	—	—	—	—	12	
	STC CCR, @-ERd	W						4				ERd32-2 → ERd32 CCR → @ERd	—	—	—	—	—	—	—	8	
	STC CCR, @aa:16	W							6			CCR → @aa:16	—	—	—	—	—	—	—	8	
	STC CCR, @aa:24	W								8		CCR → @aa:24	—	—	—	—	—	—	—	10	
ANDC	ANDC #xx:8, CCR	B	2									CCR^#xx:8 → CCR	↑	↑	↑	↑	↑	↑	↑	2	
ORC	ORC #xx:8, CCR	B	2									CCR#xx:8 → CCR	↑	↑	↑	↑	↑	↑	↑	2	
XORC	XORC #xx:8, CCR	B	2									CCR@#xx:8 → CCR	↑	↑	↑	↑	↑	↑	↑	2	
NOP	NOP	—									2	PC ← PC+2	—	—	—	—	—	—	—	2	

- Block transfer instructions

	Mnemonic	Operand Size	Addressing Mode and Instruction Length (bytes)								Operation	Condition Code						No. of States ^{*1}		
			#xx	Rn	@ERn	@ (d, ERn)	@-ERn/@ERn+	@aa	@ (d, PC)	@@aa			I	H	N	Z	V	C	Normal	Advanced
EEPMOV	EEPMOV. B	—																8+ 4n ^{*2}		
	EEPMOV. W	—																8+ 4n ^{*2}		

Notes: 1. The number of states in cases where the instruction code and its operands are located in on-chip memory is shown here. For other cases see appendix A.3, Number of Execution States.

2. n is the value set in register R4L or R4.

- (1) Set to 1 when a carry or borrow occurs at bit 11; otherwise cleared to 0.
- (2) Set to 1 when a carry or borrow occurs at bit 27; otherwise cleared to 0.
- (3) Retains its previous value when the result is zero; otherwise cleared to 0.
- (4) Set to 1 when the adjustment produces a carry; otherwise retains its previous value.
- (5) The number of states required for execution of an instruction that transfers data in synchronization with the E clock is variable.
- (6) Set to 1 when the divisor is negative; otherwise cleared to 0.
- (7) Set to 1 when the divisor is zero; otherwise cleared to 0.
- (8) Set to 1 when the quotient is negative; otherwise cleared to 0.

A.2 Operation Code Map

Table A.2 Operation Code Map (1)

Instruction code:

1st byte	2nd byte
AH AL	BH BL

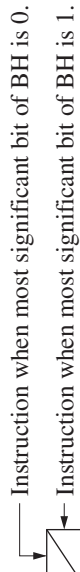

AL/AH	0	1	2	3	4	5	6	7	8	9	A	B	C	D	E	F	
0	NOP	Table A-2 (2)	STC	LDC	ORC	XORC	ANDC	LDC	ADD	Table A-2 (2)	Table A-2 (2)	Table A-2 (2)	Table A-2 (2)	MOV	ADDX	Table A-2 (2)	
1	Table A-2 (2)	Table A-2 (2)	Table A-2 (2)	Table A-2 (2)	OR.B	XOR.B	AND.B	Table A-2 (2)	SUB	Table A-2 (2)	Table A-2 (2)	Table A-2 (2)	Table A-2 (2)	CMP	SUBX	Table A-2 (2)	
2	MOV.B																
3	MOV																
4	BRA	BRN	BHI	BLS	BCC	BCS	BNE	BEQ	BVC	BVS	BPL	BMI	BGE	BLT	BGT	BLE	
5	MULXU	DIVXU	MULXU	DIVXU	RTS	BSR	RTE	TRAPA	Table A-2 (2)		JMP		BSR		JSR		
6	BSET	BNOT	BCLR	BTST	OR	XOR	AND	BST	MOV								
7					BOR	BXOR	BAND	BLD	MOV	Table A-2 (2)	Table A-2 (2)	EEMOV				Table A-2 (3)	
8	ADD																
9	ADDX																
A	CMP																
B	SUBX																
C	OR																
D	XOR																
E	AND																
F	MOV																

Table A.2 Operation Code Map (3)

Instruction code:		1st byte		2nd byte		3rd byte		4th byte										
		AH	AL	BH	BL	CH	CL	DH	DL									
CL		0	1	2	3	4	5	6	7	8	9	A	B	C	D	E	F	
AH ALBH BLCH															LDC	STC	LDC	STC
01406															LDC	STC		
01C05	MULXS																	
01D05		DIVXS																
01F06							OR	XOR	AND									
7C06*1																		
7C07*1																		
7D06*1	BSET																	
7D07*1	BSET																	
7Eaa6*2																		
7Eaa7*2																		
7Faa6*2	BSET																	
7Faa7*2	BSET																	

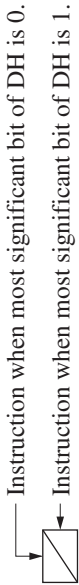

Notes: 1. r is the register designation field.
2. aa is the absolute address field.

A.3 Number of Execution States

The status of execution for each instruction of the H8/300H CPU and the method of calculating the number of states required for instruction execution are shown below. Table A.4 shows the number of cycles of each type occurring in each instruction, such as instruction fetch and data read/write. Table A.3 shows the number of states required for each cycle. The total number of states required for execution of an instruction can be calculated by the following expression:

$$\text{Execution states} = I \times S_I + J \times S_J + K \times S_K + L \times S_L + M \times S_M + N \times S_N$$

Examples: When instruction is fetched from on-chip ROM, and an on-chip RAM is accessed.

BSET #0, @FF00

From table A.4:

$$I = L = 2, \quad J = K = M = N = 0$$

From table A.3:

$$S_I = 2, \quad S_L = 2$$

$$\text{Number of states required for execution} = 2 \times 2 + 2 \times 2 = 8$$

When instruction is fetched from on-chip ROM, branch address is read from on-chip ROM, and on-chip RAM is used for stack area.

JSR @@ 30

From table A.4:

$$I = 2, \quad J = K = 1, \quad L = M = N = 0$$

From table A.3:

$$S_I = S_J = S_K = 2$$

$$\text{Number of states required for execution} = 2 \times 2 + 1 \times 2 + 1 \times 2 = 8$$

Table A.3 Number of Cycles in Each Instruction

Execution Status (Instruction Cycle)		Access Location	
		On-Chip Memory	On-Chip Peripheral Module
Instruction fetch	S_I	2	—
Branch address read	S_J		
Stack operation	S_K		
Byte data access	S_L		2 or 3*
Word data access	S_M		2 or 3*
Internal operation	S_N		1

Note: * Depends on which on-chip peripheral module is accessed. See section 19.1, Register Addresses (Address Order).

Table A.4 Number of Cycles in Each Instruction

Instruction	Mnemonic	Instruction	Branch	Stack	Byte Data	Word Data	Internal
		Fetch	Addr. Read	Operation	Access	Access	Operation
		I	J	K	L	M	N
ADD	ADD.B #xx:8, Rd	1					
	ADD.B Rs, Rd	1					
	ADD.W #xx:16, Rd	2					
	ADD.W Rs, Rd	1					
	ADD.L #xx:32, ERd	3					
	ADD.L ERs, ERd	1					
ADDS	ADDS #1/2/4, ERd	1					
ADDX	ADDX #xx:8, Rd	1					
	ADDX Rs, Rd	1					
AND	AND.B #xx:8, Rd	1					
	AND.B Rs, Rd	1					
	AND.W #xx:16, Rd	2					
	AND.W Rs, Rd	1					
	AND.L #xx:32, ERd	3					
	AND.L ERs, ERd	2					
ANDC	ANDC #xx:8, CCR	1					
BAND	BAND #xx:3, Rd	1					
	BAND #xx:3, @ERd	2			1		
	BAND #xx:3, @aa:8	2			1		
Bcc	BRA d:8 (BT d:8)	2					
	BRN d:8 (BF d:8)	2					
	BHI d:8	2					
	BLS d:8	2					
	BCC d:8 (BHS d:8)	2					
	BCS d:8 (BLO d:8)	2					
	BNE d:8	2					
	BEQ d:8	2					
	BVC d:8	2					
	BVS d:8	2					
	BPL d:8	2					
	BMI d:8	2					
	BGE d:8	2					

Instruction	Mnemonic	Instruction	Branch	Stack	Byte Data	Word Data	Internal
		Fetch	Addr. Read	Operation	Access	Access	Operation
		I	J	K	L	M	N
Bcc	BLT d:8	2					
	BGT d:8	2					
	BLE d:8	2					
	BRA d:16(BT d:16)	2					2
	BRN d:16(BF d:16)	2					2
	BHI d:16	2					2
	BLS d:16	2					2
	BCC d:16(BHS d:16)	2					2
	BCS d:16(BLO d:16)	2					2
	BNE d:16	2					2
	BEQ d:16	2					2
	BVC d:16	2					2
	BVS d:16	2					2
	BPL d:16	2					2
	BMI d:16	2					2
	BGE d:16	2					2
	BLT d:16	2					2
BGT d:16	2					2	
BLE d:16	2					2	
BCLR	BCLR #xx:3, Rd	1					
	BCLR #xx:3, @ERd	2			2		
	BCLR #xx:3, @aa:8	2			2		
	BCLR Rn, Rd	1					
	BCLR Rn, @ERd	2			2		
	BCLR Rn, @aa:8	2			2		
BIAND	BIAND #xx:3, Rd	1					
	BIAND #xx:3, @ERd	2			1		
	BIAND #xx:3, @aa:8	2			1		
BILD	BILD #xx:3, Rd	1					
	BILD #xx:3, @ERd	2			1		
	BILD #xx:3, @aa:8	2			1		

Instruction	Mnemonic	Instruction	Branch	Stack	Byte Data	Word Data	Internal
		Fetch	Addr. Read	Operation	Access	Access	Operation
		I	J	K	L	M	N
BIOR	BIOR #xx:8, Rd	1					
	BIOR #xx:8, @ERd	2			1		
	BIOR #xx:8, @aa:8	2			1		
BIST	BIST #xx:3, Rd	1					
	BIST #xx:3, @ERd	2			2		
	BIST #xx:3, @aa:8	2			2		
BIXOR	BIXOR #xx:3, Rd	1					
	BIXOR #xx:3, @ERd	2			1		
	BIXOR #xx:3, @aa:8	2			1		
BLD	BLD #xx:3, Rd	1					
	BLD #xx:3, @ERd	2			1		
	BLD #xx:3, @aa:8	2			1		
BNOT	BNOT #xx:3, Rd	1					
	BNOT #xx:3, @ERd	2			2		
	BNOT #xx:3, @aa:8	2			2		
	BNOT Rn, Rd	1					
	BNOT Rn, @ERd	2			2		
	BNOT Rn, @aa:8	2			2		
BOR	BOR #xx:3, Rd	1					
	BOR #xx:3, @ERd	2			1		
	BOR #xx:3, @aa:8	2			1		
BSET	BSET #xx:3, Rd	1					
	BSET #xx:3, @ERd	2			2		
	BSET #xx:3, @aa:8	2			2		
	BSET Rn, Rd	1					
	BSET Rn, @ERd	2			2		
	BSET Rn, @aa:8	2			2		
BSR	BSR d:8	2		1			
	BSR d:16	2		1			2
BST	BST #xx:3, Rd	1					
	BST #xx:3, @ERd	2			2		
	BST #xx:3, @aa:8	2			2		

Instruction	Mnemonic	Instruction	Branch	Stack	Byte Data	Word Data	Internal
		Fetch	Addr. Read	Operation	Access	Access	Operation
		I	J	K	L	M	N
BTST	BTST #xx:3, Rd	1					
	BTST #xx:3, @ERd	2			1		
	BTST #xx:3, @aa:8	2			1		
	BTST Rn, Rd	1					
	BTST Rn, @ERd	2			1		
	BTST Rn, @aa:8	2			1		
BXOR	BXOR #xx:3, Rd	1					
	BXOR #xx:3, @ERd	2			1		
	BXOR #xx:3, @aa:8	2			1		
CMP	CMP.B #xx:8, Rd	1					
	CMP.B Rs, Rd	1					
	CMP.W #xx:16, Rd	2					
	CMP.W Rs, Rd	1					
	CMP.L #xx:32, ERd	3					
	CMP.L ERs, ERd	1					
DAA	DAA Rd	1					
DAS	DAS Rd	1					
DEC	DEC.B Rd	1					
	DEC.W #1/2, Rd	1					
	DEC.L #1/2, ERd	1					
DIVXS	DIVXS.B Rs, Rd	2					12
	DIVXS.W Rs, ERd	2					20
DIVXU	DIVXU.B Rs, Rd	1					12
	DIVXU.W Rs, ERd	1					20
EEPMOV	EEPMOV.B	2			$2n+2^{*1}$		
	EEPMOV.W	2			$2n+2^{*1}$		
EXTS	EXTS.W Rd	1					
	EXTS.L ERd	1					
EXTU	EXTU.W Rd	1					
	EXTU.L ERd	1					

Instruction	Mnemonic	Instruction	Branch	Stack	Byte Data	Word Data	Internal
		Fetch	Addr. Read	Operation	Access	Access	Operation
		I	J	K	L	M	N
INC	INC.B Rd	1					
	INC.W #1/2, Rd	1					
	INC.L #1/2, ERd	1					
JMP	JMP @ERn	2					
	JMP @aa:24	2					2
	JMP @ @aa:8	2	1				2
JSR	JSR @ERn	2		1			
	JSR @aa:24	2		1			2
	JSR @ @aa:8	2	1	1			
LDC	LDC #xx:8, CCR	1					
	LDC Rs, CCR	1					
	LDC@ERs, CCR	2				1	
	LDC@(d:16, ERs), CCR	3				1	
	LDC@(d:24,ERs), CCR	5				1	
	LDC@ERs+, CCR	2				1	2
	LDC@aa:16, CCR	3				1	
	LDC@aa:24, CCR	4				1	
MOV	MOV.B #xx:8, Rd	1					
	MOV.B Rs, Rd	1					
	MOV.B @ERs, Rd	1			1		
	MOV.B @(d:16, ERs), Rd	2			1		
	MOV.B @(d:24, ERs), Rd	4			1		
	MOV.B @ERs+, Rd	1			1		2
	MOV.B @aa:8, Rd	1			1		
	MOV.B @aa:16, Rd	2			1		
	MOV.B @aa:24, Rd	3			1		
	MOV.B Rs, @ERd	1			1		
	MOV.B Rs, @(d:16, ERd)	2			1		
	MOV.B Rs, @(d:24, ERd)	4			1		
	MOV.B Rs, @-ERd	1			1		2
	MOV.B Rs, @aa:8	1			1		

Instruction	Mnemonic	Instruction	Branch	Stack	Byte Data	Word Data	Internal
		Fetch	Addr. Read	Operation	Access	Access	Operation
		I	J	K	L	M	N
MOV	MOV.B Rs, @aa:16	2			1		
	MOV.B Rs, @aa:24	3			1		
	MOV.W #xx:16, Rd	2					
	MOV.W Rs, Rd	1					
	MOV.W @ERs, Rd	1				1	
	MOV.W @(d:16,ERs), Rd	2				1	
	MOV.W @(d:24,ERs), Rd	4				1	
	MOV.W @ERs+, Rd	1				1	2
	MOV.W @aa:16, Rd	2				1	
	MOV.W @aa:24, Rd	3				1	
	MOV.W Rs, @ERd	1				1	
	MOV.W Rs, @(d:16,ERd)	2				1	
	MOV.W Rs, @(d:24,ERd)	4				1	
MOV	MOV.W Rs, @-ERd	1				1	2
	MOV.W Rs, @aa:16	2				1	
	MOV.W Rs, @aa:24	3				1	
	MOV.L #xx:32, ERd	3					
	MOV.L ERs, ERd	1					
	MOV.L @ERs, ERd	2				2	
	MOV.L @(d:16,ERs), ERd	3				2	
	MOV.L @(d:24,ERs), ERd	5				2	
	MOV.L @ERs+, ERd	2				2	2
	MOV.L @aa:16, ERd	3				2	
	MOV.L @aa:24, ERd	4				2	
	MOV.L ERs, @ERd	2				2	
	MOV.L ERs, @(d:16,ERd)	3				2	
	MOV.L ERs, @(d:24,ERd)	5				2	
	MOV.L ERs, @-ERd	2				2	2
	MOV.L ERs, @aa:16	3				2	
	MOV.L ERs, @aa:24	4				2	
MOVFP	MOVFP @aa:16, Rd* ²	2			1		
MOVTP	MOVTP Rs, @aa:16* ²	2			1		

Instruction	Mnemonic	Instruction	Branch	Stack	Byte Data	Word Data	Internal
		Fetch	Addr. Read	Operation	Access	Access	Operation
		I	J	K	L	M	N
MULXS	MULXS.B Rs, Rd	2					12
	MULXS.W Rs, ERd	2					20
MULXU	MULXU.B Rs, Rd	1					12
	MULXU.W Rs, ERd	1					20
NEG	NEG.B Rd	1					
	NEG.W Rd	1					
	NEG.L ERd	1					
NOP	NOP	1					
NOT	NOT.B Rd	1					
	NOT.W Rd	1					
	NOT.L ERd	1					
OR	OR.B #xx:8, Rd	1					
	OR.B Rs, Rd	1					
	OR.W #xx:16, Rd	2					
	OR.W Rs, Rd	1					
	OR.L #xx:32, ERd	3					
	OR.L ERs, ERd	2					
ORC	ORC #xx:8, CCR	1					
POP	POP.W Rn	1				1	2
	POP.L ERn	2				2	2
PUSH	PUSH.W Rn	1				1	2
	PUSH.L ERn	2				2	2
ROTL	ROTL.B Rd	1					
	ROTL.W Rd	1					
	ROTL.L ERd	1					
ROTR	ROTR.B Rd	1					
	ROTR.W Rd	1					
	ROTR.L ERd	1					
ROTXL	ROTXL.B Rd	1					
	ROTXL.W Rd	1					
	ROTXL.L ERd	1					

Instruction	Mnemonic	Instruction	Branch	Stack	Byte Data	Word Data	Internal
		Fetch	Addr. Read	Operation	Access	Access	Operation
		I	J	K	L	M	N
ROTXR	ROTXR.B Rd	1					
	ROTXR.W Rd	1					
	ROTXR.L ERd	1					
RTE	RTE	2		2			2
RTS	RTS	2		1			2
SHAL	SHAL.B Rd	1					
	SHAL.W Rd	1					
	SHAL.L ERd	1					
SHAR	SHAR.B Rd	1					
	SHAR.W Rd	1					
	SHAR.L ERd	1					
SHLL	SHLL.B Rd	1					
	SHLL.W Rd	1					
	SHLL.L ERd	1					
SHLR	SHLR.B Rd	1					
	SHLR.W Rd	1					
	SHLR.L ERd	1					
SLEEP	SLEEP	1					
STC	STC CCR, Rd	1					
	STC CCR, @ERd	2				1	
	STC CCR, @(d:16,ERd)	3				1	
	STC CCR, @(d:24,ERd)	5				1	
	STC CCR, @-ERd	2				1	2
	STC CCR, @aa:16	3				1	
	STC CCR, @aa:24	4				1	
SUB	SUB.B Rs, Rd	1					
	SUB.W #xx:16, Rd	2					
	SUB.W Rs, Rd	1					
	SUB.L #xx:32, ERd	3					
	SUB.L ERs, ERd	1					
SUBS	SUBS #1/2/4, ERd	1					

Instruction	Mnemonic	Instruction	Branch	Stack	Byte Data	Word Data	Internal
		Fetch	Addr. Read	Operation	Access	Access	Operation
		I	J	K	L	M	N
SUBX	SUBX #xx:8, Rd	1					
	SUBX. Rs, Rd	1					
TRAPA	TRAPA #xx:2	2	1	2			4
XOR	XOR.B #xx:8, Rd	1					
	XOR.B Rs, Rd	1					
	XOR.W #xx:16, Rd	2					
	XOR.W Rs, Rd	1					
	XOR.L #xx:32, ERd	3					
	XOR.L ERs, ERd	2					
XORC	XORC #xx:8, CCR	1					

- Notes:
1. n: Specified value in R4L and R4. The source and destination operands are accessed n+1 times respectively.
 2. Cannot be used in this LSI.

A.4 Combinations of Instructions and Addressing Modes

Table A.5 Combinations of Instructions and Addressing Modes

Functions	Instructions	Addressing Mode												
		#xx	Rn	@ERn	@(d:16.ERn)	@(d:24.ERn)	@ERn+/@ERn	@aa:8	@aa:16	@aa:24	@(d:8.PC)	@(d:16.PC)	@aa:8	
Data transfer instructions	MOV	BWL	BWL	BWL	BWL	BWL	BWL	B	BWL	BWL	—	—	—	—
	POP, PUSH	—	—	—	—	—	—	—	—	—	—	—	—	WL
	MOVFP, MOVTPE	—	—	—	—	—	—	—	—	—	—	—	—	—
Arithmetic operations	ADD, CMP	BWL	BWL	—	—	—	—	—	—	—	—	—	—	—
	SUB	WL	BWL	—	—	—	—	—	—	—	—	—	—	—
	ADDX, SUBX	B	B	—	—	—	—	—	—	—	—	—	—	—
	ADDS, SUBS	—	L	—	—	—	—	—	—	—	—	—	—	—
	INC, DEC	—	BWL	—	—	—	—	—	—	—	—	—	—	—
	DAA, DAS	—	B	—	—	—	—	—	—	—	—	—	—	—
	MULXU, MULXS, DIVXU, DIVXS	—	BW	—	—	—	—	—	—	—	—	—	—	—
	NEG	—	BWL	—	—	—	—	—	—	—	—	—	—	—
EXTU, EXTS	—	WL	—	—	—	—	—	—	—	—	—	—	—	
Logical operations	AND, OR, XOR	—	BWL	—	—	—	—	—	—	—	—	—	—	—
	NOT	—	BWL	—	—	—	—	—	—	—	—	—	—	—
Shift operations		—	BWL	—	—	—	—	—	—	—	—	—	—	—
Bit manipulations		—	B	B	—	—	—	B	—	—	—	—	—	—
Branching instructions	BCC, BSR	—	—	—	—	—	—	—	—	—	—	—	—	—
	JMP, JSR	—	—	○	—	—	—	—	—	—	○	○	—	—
	RTS	—	—	—	—	—	—	—	—	○	—	—	○	—
System control instructions	TRAPA	—	—	—	—	—	—	—	—	—	—	—	—	○
	RTE	—	—	—	—	—	—	—	—	—	—	—	—	○
	SLEEP	—	—	—	—	—	—	—	—	—	—	—	—	○
	LDC	B	B	W	W	W	W	—	W	W	—	—	—	○
	STC	—	B	W	W	W	W	—	W	W	—	—	—	—
	ANDC, ORC, XORC	B	—	—	—	—	—	—	—	—	—	—	—	—
NOP	—	—	—	—	—	—	—	—	—	—	—	—	○	
Block data transfer instructions		—	—	—	—	—	—	—	—	—	—	—	—	BW

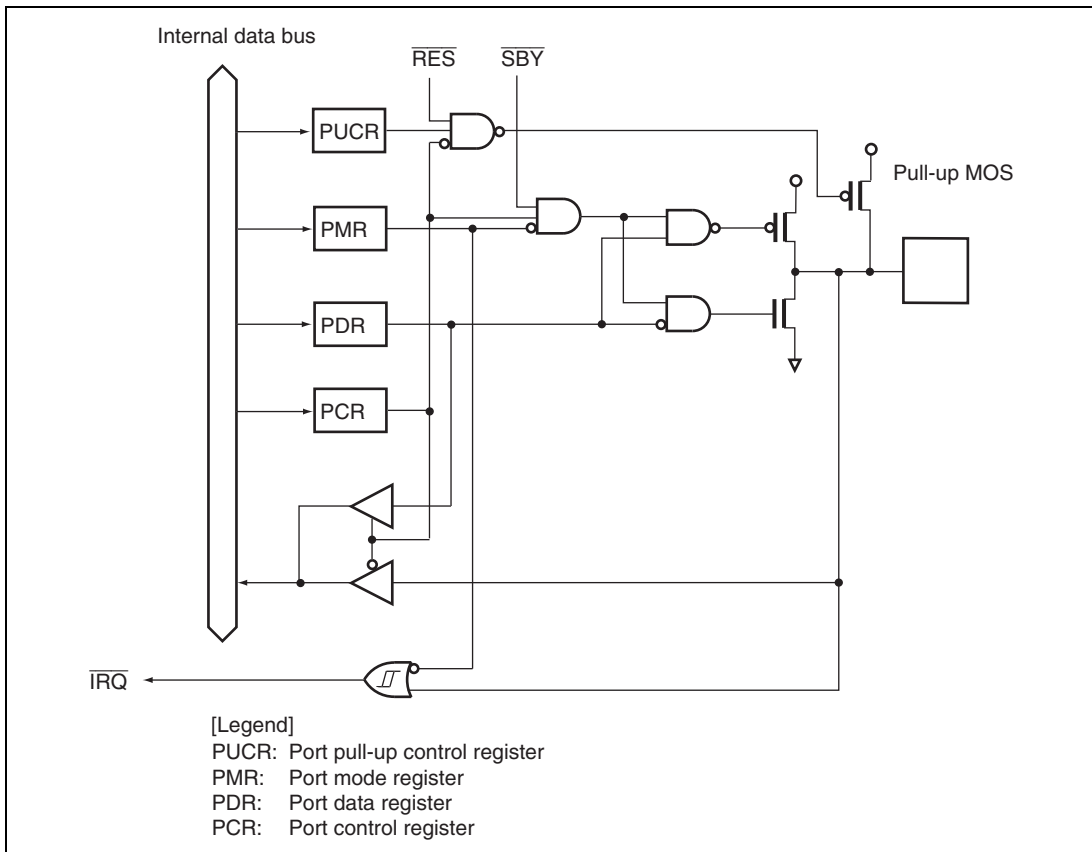

Figure B.2 Port 1 Block Diagram (P14)

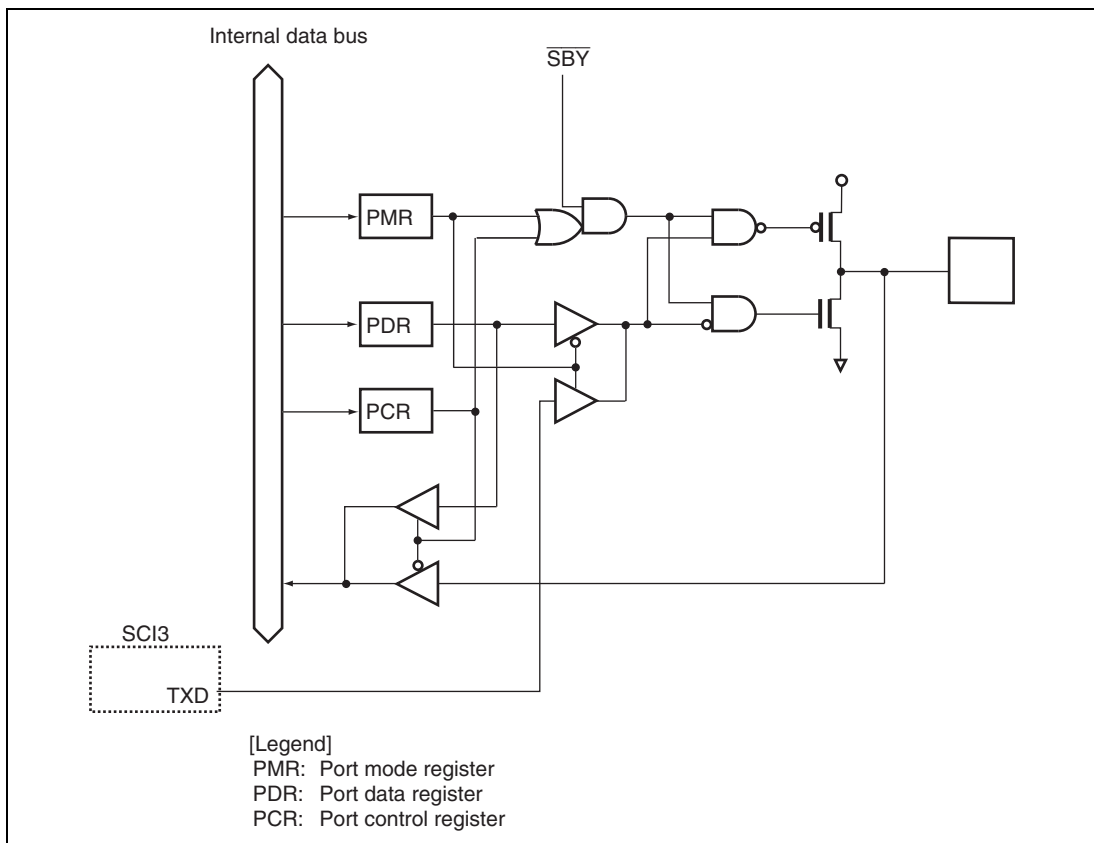

Figure B.3 Port 2 Block Diagram (P22)

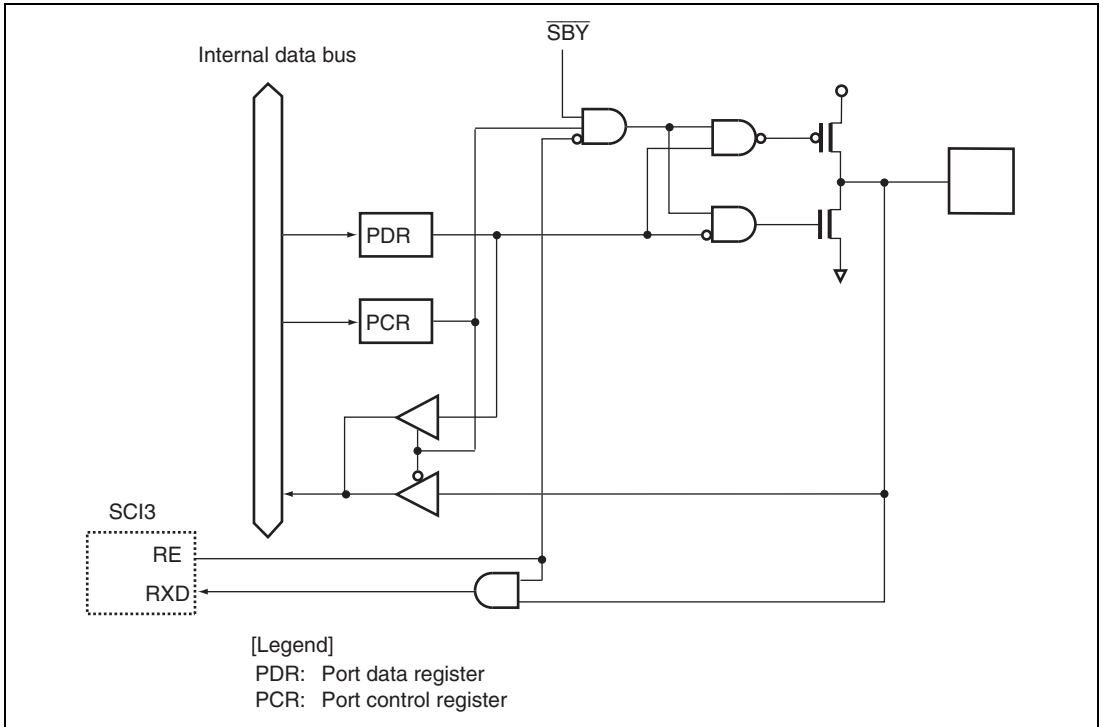

Figure B.4 Port 2 Block Diagram (P21)

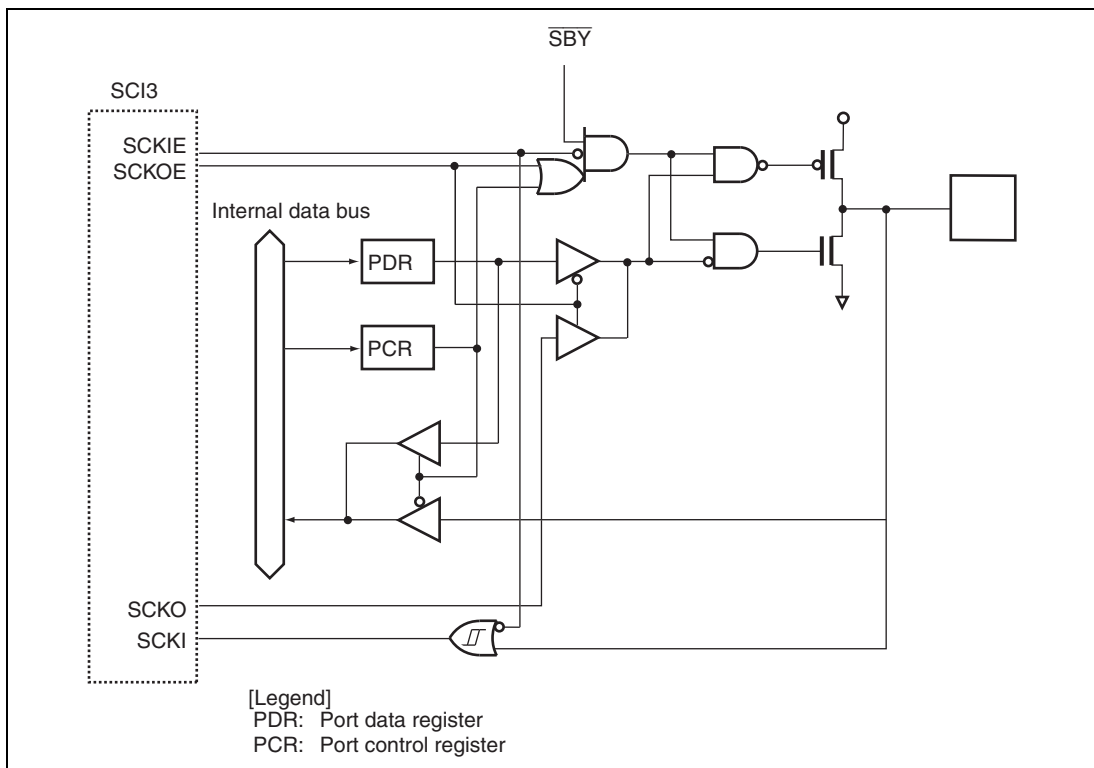

Figure B.5 Port 2 Block Diagram (P20)

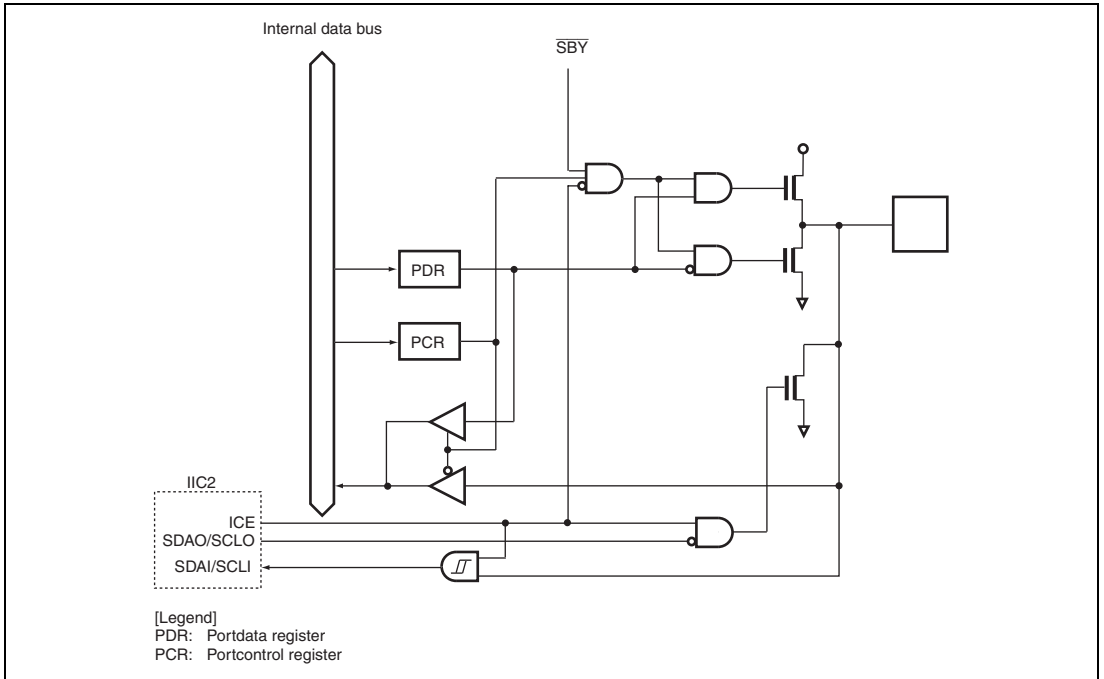

Figure B.6 (1) Port 5 Block Diagram (P57, P56) (for H8/36912 Group)

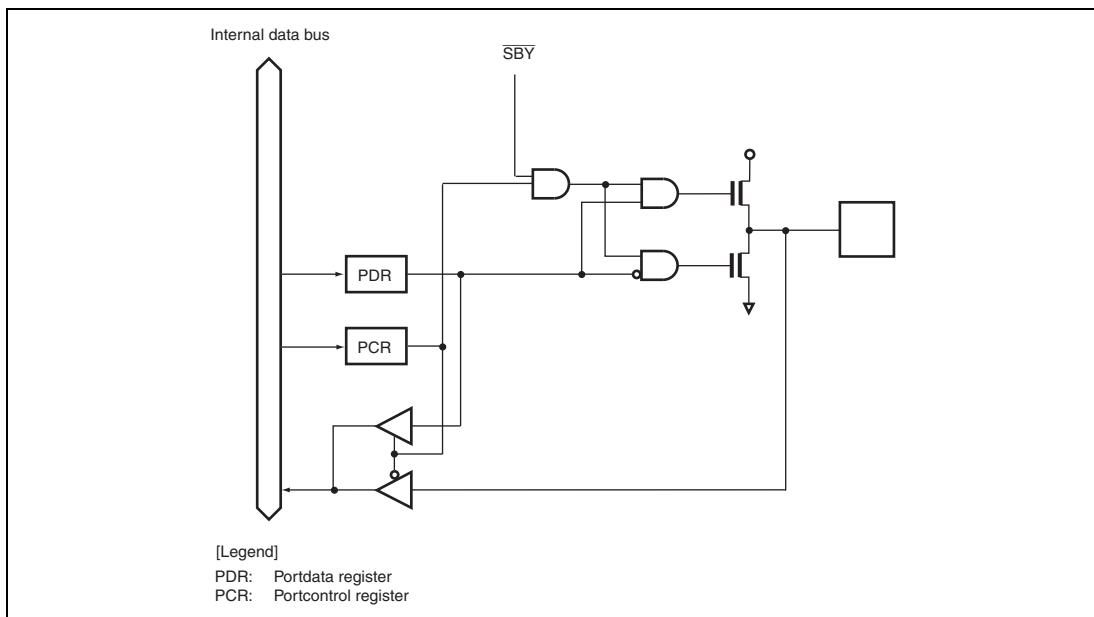

Figure B.6 (2) Port 5 Block Diagram (P57, P56) (for H8/36902 Group)

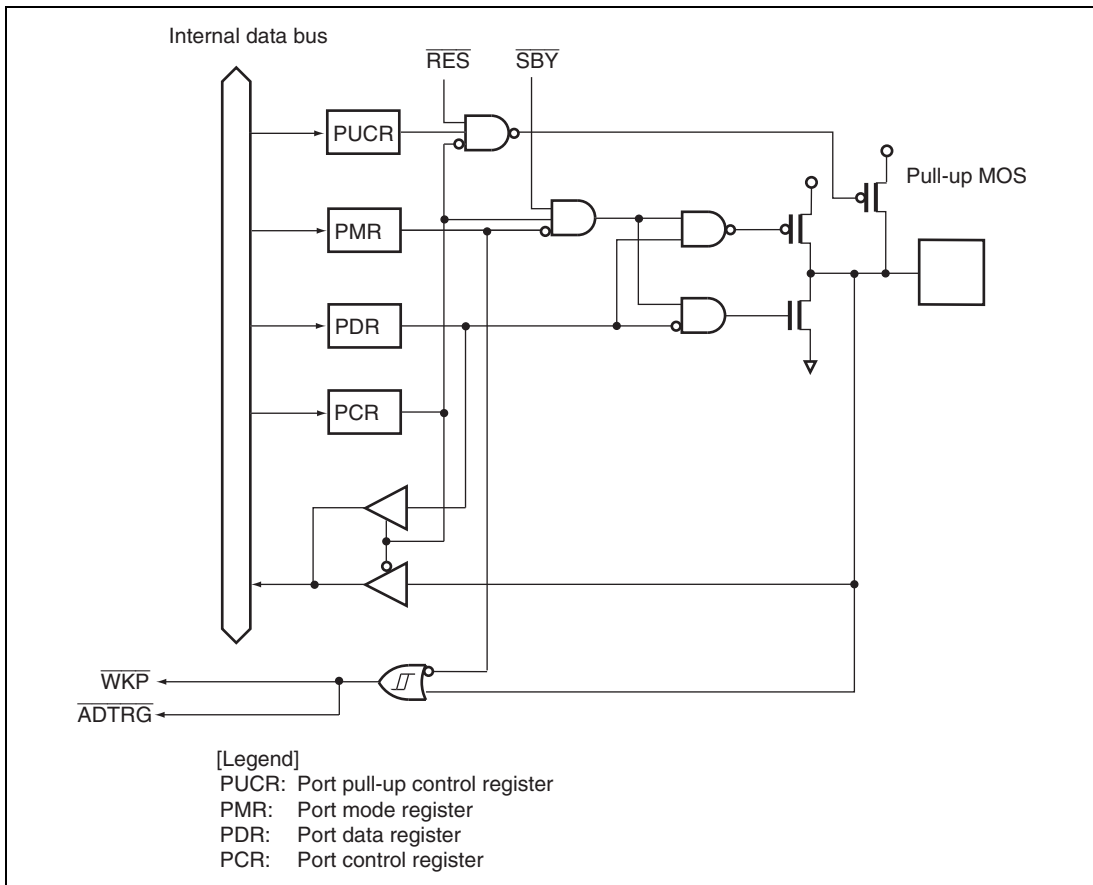

Figure B.7 Port 5 Block Diagram (P55)

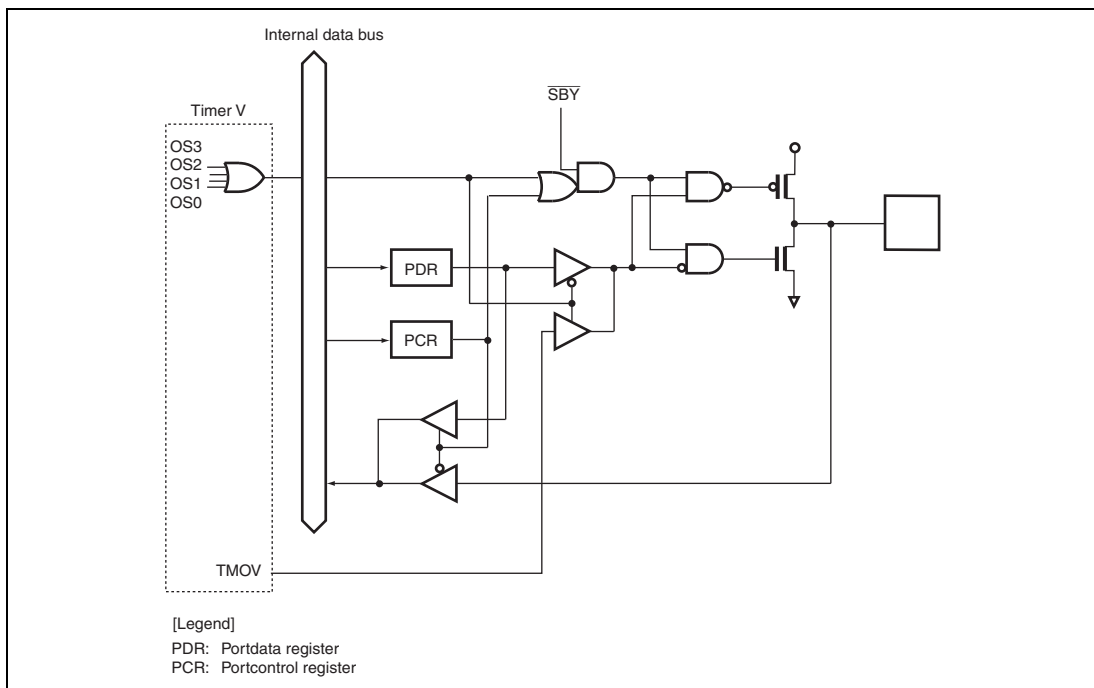

Figure B.8 Port 5 Block Diagram (P76)

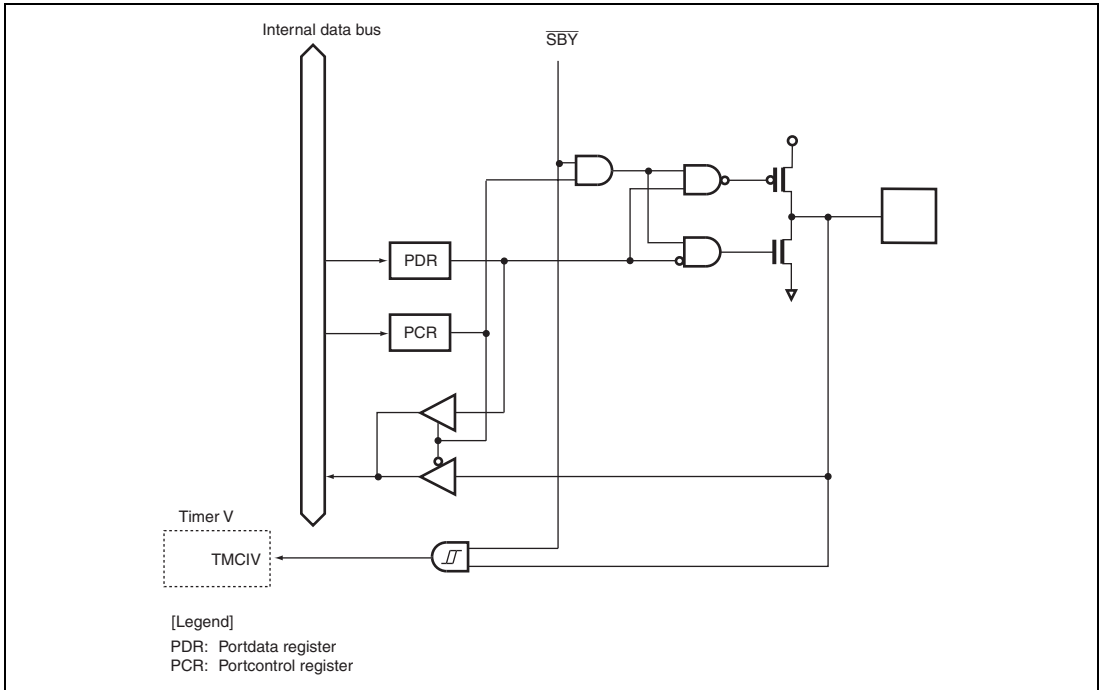

Figure B.9 Port 7 Block Diagram (P75)

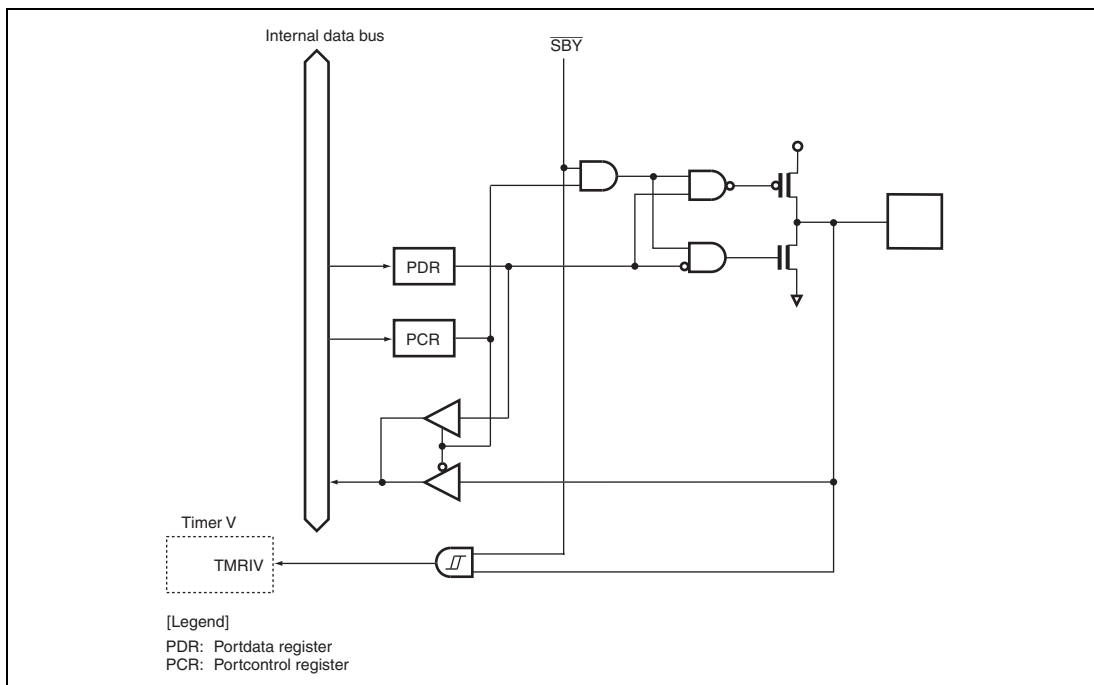

Figure B.10 Port 7 Block Diagram (P74)

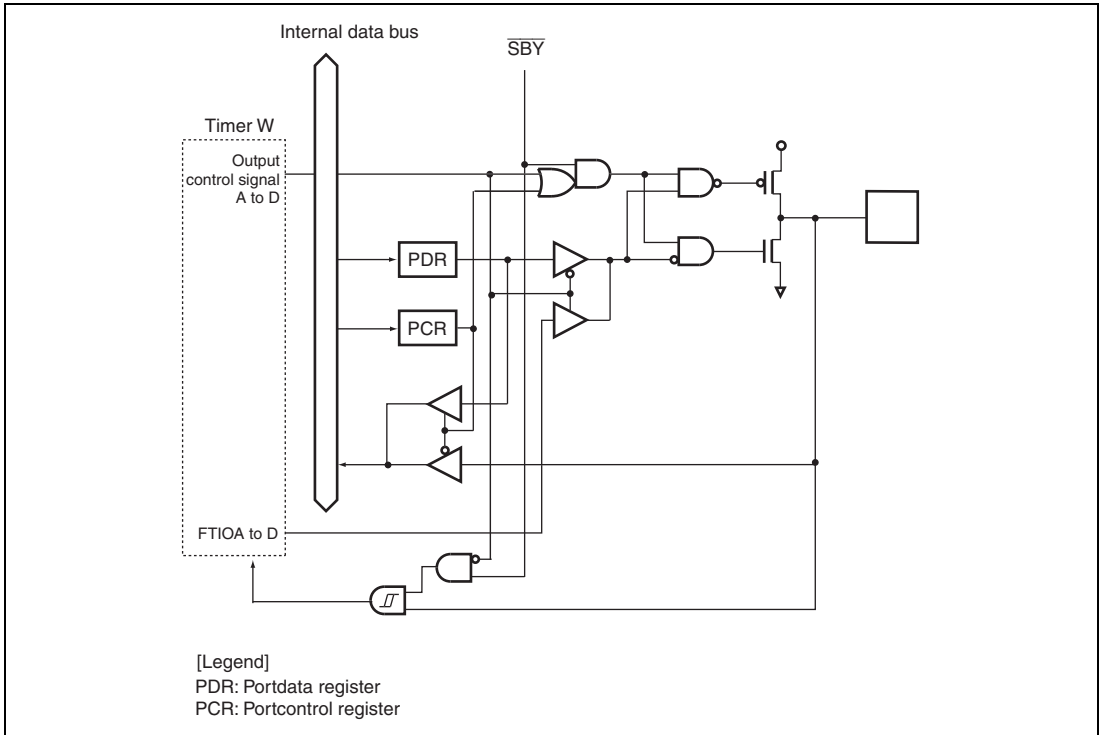

Figure B.11 Port 8 Block Diagram (P84 to P81)

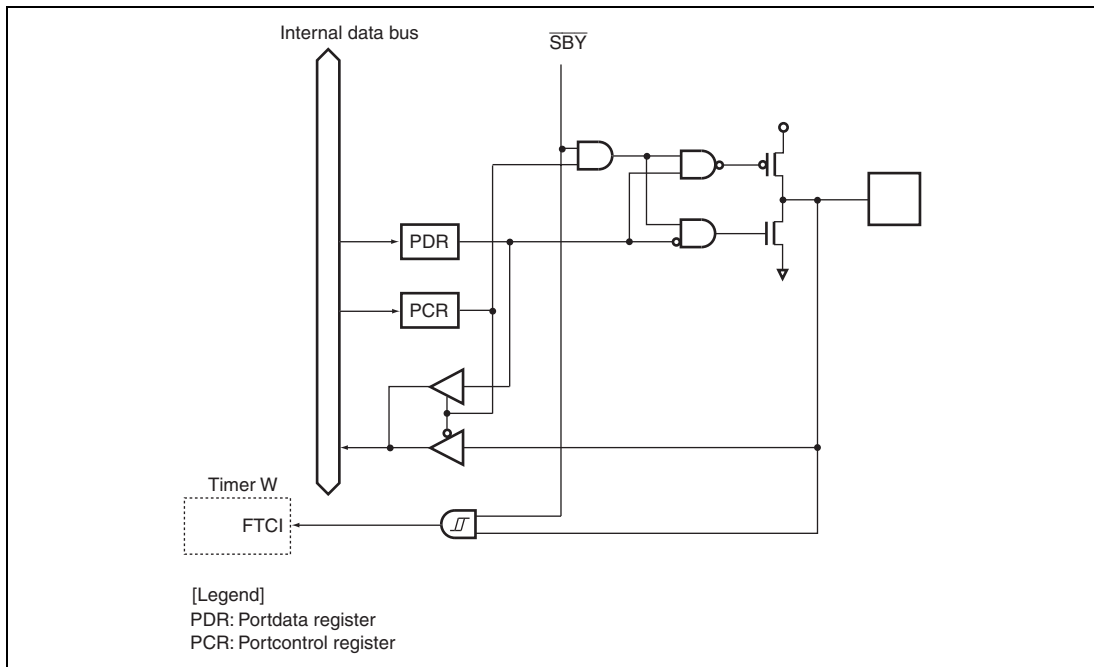

Figure B.12 Port 8 Block Diagram (P80)

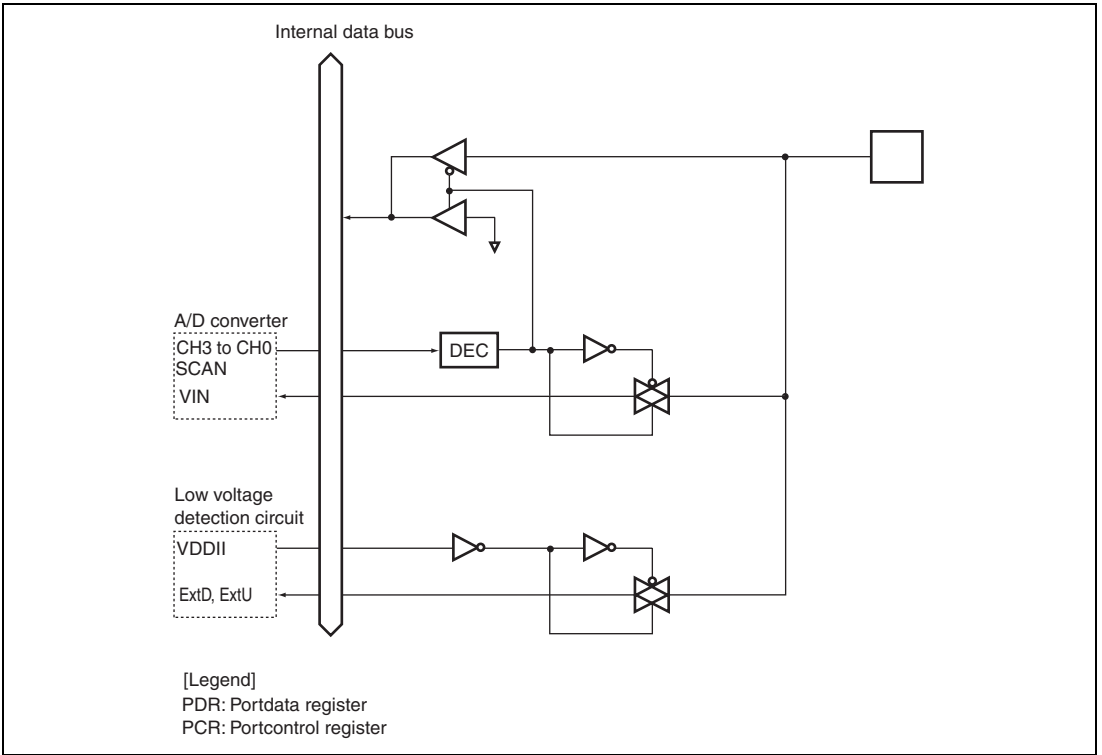

Figure B.13 Port B Block Diagram (PB3, PB2)

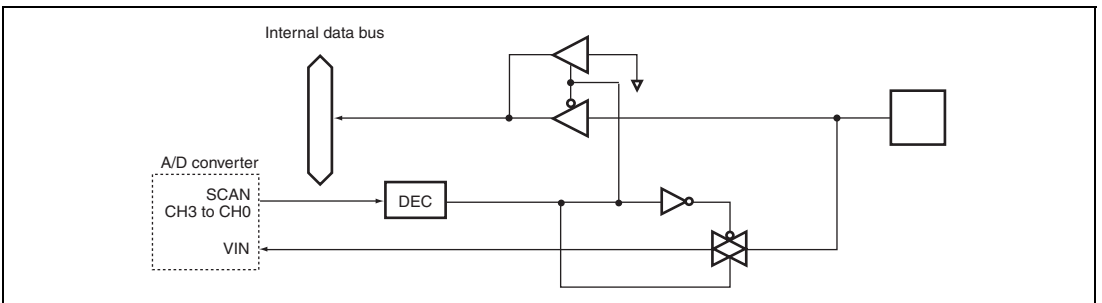

Figure B.14 Port B Block Diagram (PB1, PB0)

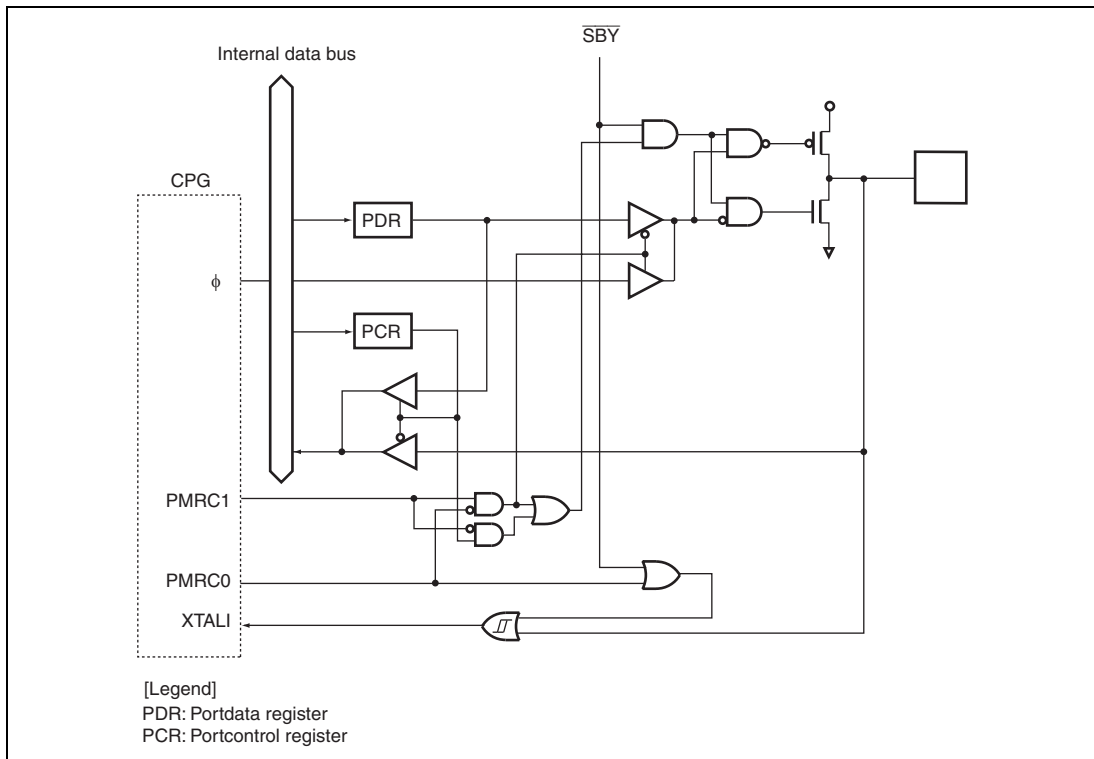

Figure B.15 Port C Block Diagram (PC1)

Appendix C Product Code Lineup

Product Type	Product Code	Model Marking	Package Code
H8/36912 Flash memory version	HD64F36912G	HD64F36912GFH	LQFP-32 (FP-32A)
		HD64F36912GTP	SOP-32 (FP-32D)
		HD64F36912GP	SDIP-32 (32P4B)
Masked ROM version	HD64336912G	HD64336912G (***) FH	LQFP-32 (FP-32A)
		HD64336912G (***) TP	SOP-32 (FP-32D)
H8/36911 Masked ROM version	HD64336911G	HD64336911G (***) FH	LQFP-32 (FP-32A)
		HD64336911G (***) TP	SOP-32 (FP-32D)
H8/36902 Flash memory version	HD64F36902G	HD64F36902GFH	LQFP-32 (FP-32A)
		HD64F36902GTP	SOP-32 (FP-32D)
		HD64F36902GP	SDIP-32 (32P4B)
Masked ROM version	HD64336902G	HD64336902G (***) FH	LQFP-32 (FP-32A)
		HD64336902G (***) TP	SOP-32 (FP-32D)
H8/36901 Masked ROM version	HD64336901G	HD64336901G (***) FH	LQFP-32 (FP-32A)
		HD64336901G (***) TP	SOP-32 (FP-32D)
H8/36900 Masked ROM version	HD64336900G	HD64336900G (***) FH	LQFP-32 (FP-32A)
		HD64336900G (***) TP	SOP-32 (FP-32D)

[Legend]

(***) : ROM code

Unit: mm

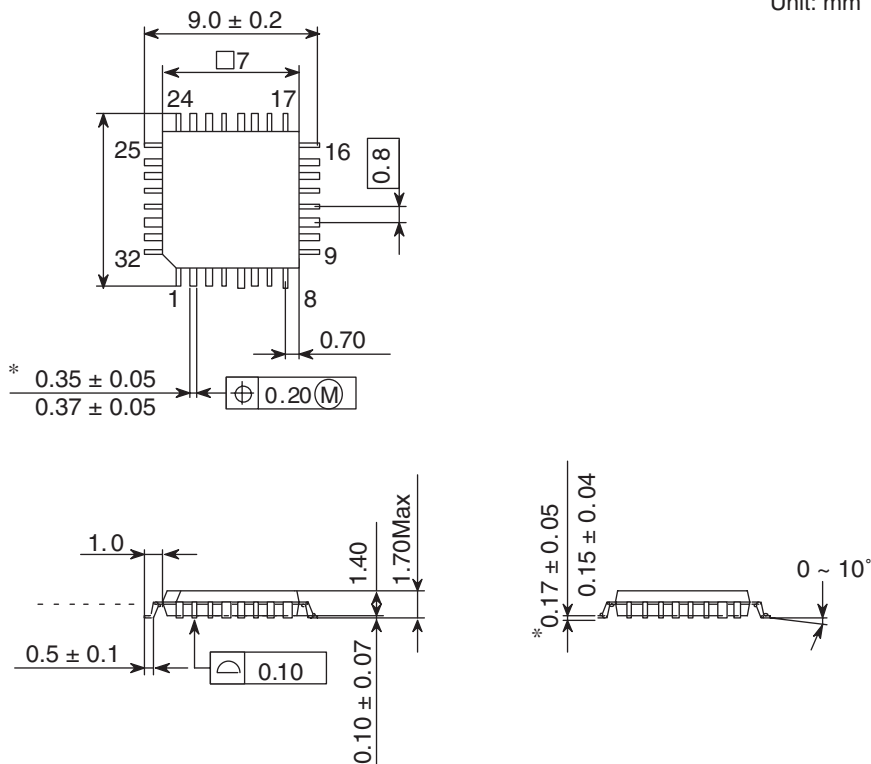

*Dimension including the plating thickness
Base material dimension

Package Code	FP-32A FP-32AV
JEDEC	—
JEITA	—
Mass (reference value)	0.2 g

Figure D.2 FP-32A Package Dimension

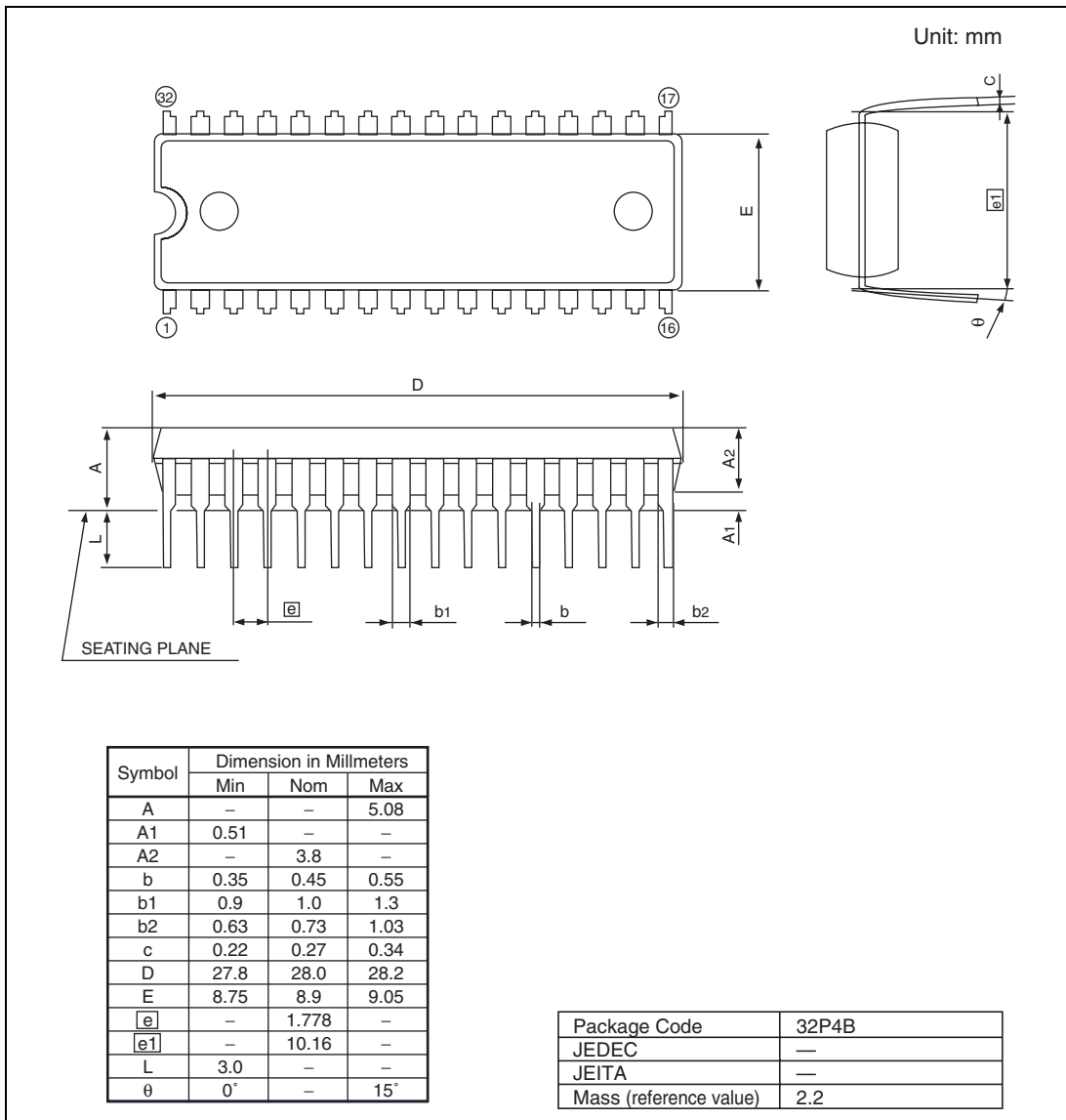

Figure D.3 32P4B Package Dimension

Main Revisions and Additions in this Edition

Item	Page	Revision (See Manual for Details)														
Preface	—	<p>When using an on-chip emulator (E7, E8) for H8/36912, H8/36902 program development and debugging, the following restrictions must be noted.</p> <ol style="list-style-type: none"> 1. The $\overline{\text{NMI}}$ pin is reserved for the E7 or E8, and cannot be used. 2. Area H'2000 to H'2FFF is used by the E7 or E8, and is not available to the user. 3. Area H'F980 to H'FD7F must on no account be accessed. 4. When the E7 or E8 is used, address breaks can be set as either available to the user or for use by the E7 or E8. If address breaks are set as being used by the E7 or E8, the address break control registers must not be accessed. 5. When the E7 or E8 is used, $\overline{\text{NMI}}$ is an input/output pin (open-drain in output mode). 														
1.1 Features	1	<ul style="list-style-type: none"> • On-chip memory <table border="1"> <thead> <tr> <th colspan="2">Product Classification</th> <th>Remarks</th> </tr> </thead> <tbody> <tr> <td rowspan="5">Masked ROM version</td> <td>H8/36912</td> <td>Under planning</td> </tr> <tr> <td>H8/36911</td> <td>Under planning</td> </tr> <tr> <td>H8/36902</td> <td>Under planning</td> </tr> <tr> <td>H8/36901</td> <td>Under planning</td> </tr> <tr> <td>H8/36900</td> <td>Under planning</td> </tr> </tbody> </table>	Product Classification		Remarks	Masked ROM version	H8/36912	Under planning	H8/36911	Under planning	H8/36902	Under planning	H8/36901	Under planning	H8/36900	Under planning
Product Classification		Remarks														
Masked ROM version	H8/36912	Under planning														
	H8/36911	Under planning														
	H8/36902	Under planning														
	H8/36901	Under planning														
	H8/36900	Under planning														
	2	<ul style="list-style-type: none"> • On-chip oscillator <p>— Frequency accuracy: 8MHz \pm1% (Typ.) $V_{cc} = 5.0\text{ V}$, $T_a = 25^\circ\text{C}$ (Flash memory version): 8MHz \pm3% $V_{cc} = 4.0$ to 5.0 V, $T_a = -20$ to 75°C 10MHz \pm4% (Typ.) $V_{cc} = 4.0$ to 5.0 V, $T_a = -20$ to 75°C</p>														
	2	<table border="1"> <thead> <tr> <th>Package</th> <th>Code</th> </tr> </thead> <tbody> <tr> <td>LQFP-32</td> <td>FP-32A</td> </tr> <tr> <td>SOP-32</td> <td>FP-32D</td> </tr> <tr> <td>SDIP-32</td> <td>32P4B</td> </tr> </tbody> </table>	Package	Code	LQFP-32	FP-32A	SOP-32	FP-32D	SDIP-32	32P4B						
Package	Code															
LQFP-32	FP-32A															
SOP-32	FP-32D															
SDIP-32	32P4B															
	2	<ul style="list-style-type: none"> • Compact package <table border="1"> <thead> <tr> <th>Package</th> </tr> </thead> <tbody> <tr> <td>LQFP-32</td> </tr> <tr> <td>SOP-32</td> </tr> <tr> <td>SDIP-32*</td> </tr> </tbody> </table> <p>Note: * Flash memory version only</p>	Package	LQFP-32	SOP-32	SDIP-32*										
Package																
LQFP-32																
SOP-32																
SDIP-32*																

Item

Page Revision (See Manual for Details)

Figure 1.1 Internal Block Diagram of H8/36912 Group 3, 4

Figure 1.2 Internal Block Diagram of H8/36902 Group

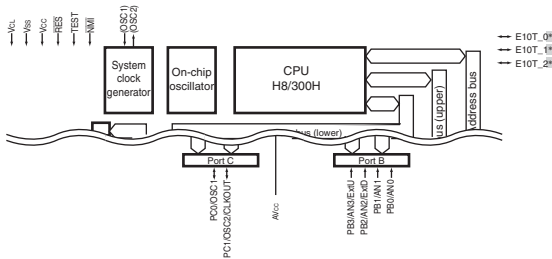

Note: * Can also be used for the E7 or E8 emulator.

Figure 1.3 Pin Arrangement of H8/36912 Group (FP-32A) 5, 6

Figure 1.4 Pin Arrangement of H8/36902 Group (FP-32A)

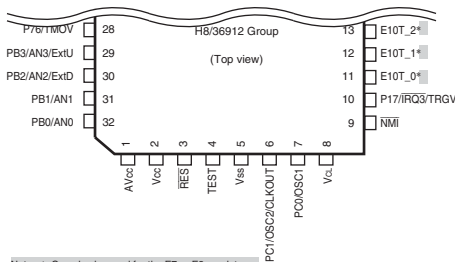

Note: * Can also be used for the E7 or E8 emulator.

Figure 1.5 Pin Arrangement of H8/36912 Group (FP-32D, 32P4B) 7, 8

Figure 1.6 Pin Arrangement of H8/36902 Group (FP-32D, 32P4B)

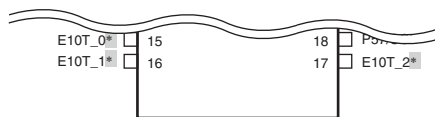

Note: * Can also be used for the E7 or E8 emulator.

Table 1.1 Pin Functions 9, 10

Type	Symbol	Pin No.		Functions
		FP-32D, 32P4B	FP-32A	
E7, E8	E10T_0,	15, 16, 17	11, 12,	Interface pins for the E7 or E8 emulator
	E10T_1,			
	E10T_2			

Section 2 CPU 11

- High-speed operation
 - All frequently-used instructions execute in two or four states

Figure 2.1 Memory Map (1) 12

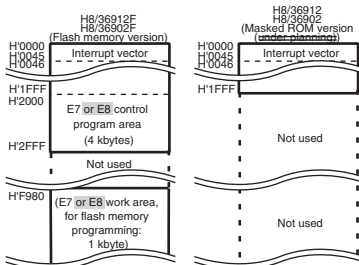

Figure 2.1 Memory Map (2) 13

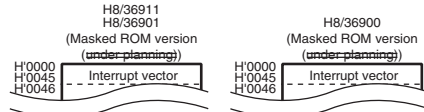
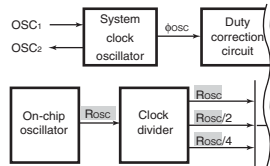

Table 3.1 Exception Sources and Vector Address 48

Relative Module	Exception Sources
IIC2*	IIC_2 transmit data empty IIC_2 transmit end IIC_2 receive error
Timer B1*	Timer B1 overflow

Note: * Available for the H8/36912 Group only.

Figure 5.1 Block Diagram of Clock Pulse Generators 69



5.2.1 RC Control Register (RCCR) 71

Bit	Bit Name	Description
1	RCPSC1	Division Ratio Select for On-chip Oscillator
0	RCPSC0	The division ratio of R_{osc} changes right after rewriting this bit.
		These bits can be written to only when the CKSTA bit in CKCSR is 0.
		0X: R_{osc} (not divided)
		10: $R_{osc}/2$
		11: $R_{osc}/4$

5.2.2 RC Trimming Data Protect Register (RCTRMDPR) 73

Bit	Bit Name	Description
4	TRMDRWE	Trimming Date Register Write Enable
		This register can be written to when the LOCKDW bit is 0 and this bit is 1.
		[Setting condition]
		<ul style="list-style-type: none"> When writing 0 to the WRI bit while writing 1 to the TRMDRWE bit while the PRWE bit is 1
		[Clearing conditions]
		<ul style="list-style-type: none"> Reset When writing 0 to the WRI bit and writing 0 to the TRMDRWE bit while the PRWE bit is 1

Item **Page** **Revision (See Manual for Details)**

5.2.3 RC Trimming Data Register (RCTRMDR) 73

Bit	Bit Name	Description
7	TRMD7	Trimming Data
6	TRMD6	In the flash memory version, the trimming data is loaded from the flash memory to this register right after a reset. These bits are always read as undefined value.
5	TRMD5	
4	TRMD4	
3	TRMD3	
2	TRMD2	As for the masked ROM version (under planning), the on-chip oscillator frequency can be trimmed by rewriting these bits.
1	TRMD1	
0	TRMD0	

5.2.4 Clock Control/Status Register (CKCSR) 74

Bit	Bit Name	Description
7	PMRC1	Port C Function Select 1 and 0
6	PMRC0	

Figure 5.5 Timing Chart of Switching On-chip Oscillator Clock to External Clock 78

Note: *The ϕ halt duration is the duration from the timing when the ϕ clock stops to the first rising edge of the ϕ_{osc} clock after six clock cycles of the ϕ_{rc} clock have elapsed.

Table 5.1 Crystal Resonator Parameters 82

Frequency (MHz)	12
R _s (Max.)	50 Ω

Section 7 ROM 97

The features of the 12-kbyte (including 4 kbytes as the E7 or E8 control program area) flash memory built into the HD64F36912G and HD64F36902G are summarized below.

Figure 7.1 Flash Memory Block Configuration 98

← Programming unit: 64 kbytes →

Table 7.3 System Clock Frequencies for which Automatic Adjustment of LSI Bit Rate is Possible 105

Host Bit Rate	System Clock Frequency Range of LSI
9600bps	8 MHz (on-chip oscillator clock)
4800bps	8 MHz (on-chip oscillator clock)
2400bps	8 MHz (on-chip oscillator clock)

Figure 7.4 Erase/Erase-Verify Flowchart 111

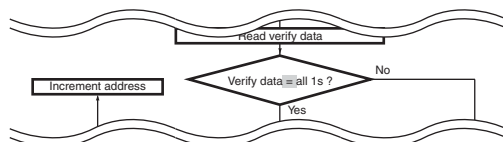

Section 8 RAM 115

Note: * When the E7 or E8 is used, area H'F980 to H'FD7F must not be accessed.

Item **Page** **Revision (See Manual for Details)**

13.2.1 Timer Control/Status Register WD (TCSRWD) 192

Bit	Bit Name	Description
4	TCSRWE	Timer Control/Status Register WD Write Enable The WDON and WRST bits can be written when the TCSRWE bit is set to 1. When writing data to this bit, the value for bit 5 must be 0.

14.8.2 Mark State and Break Sending 236 Replaced

15.3.5 I²C Bus Status Register (ICSR) 251

Bit	Bit Name	Description
3	STOP	Stop Condition Detection Flag [Setting conditions] <ul style="list-style-type: none"> In master mode, when a stop condition is detected after frame transfer In slave mode, when a stop condition is detected after the general call address or the first byte slave address, next to detection of start condition, accords with the address set in SAR

Figure 15.15 Receive Mode Operation Timing 265

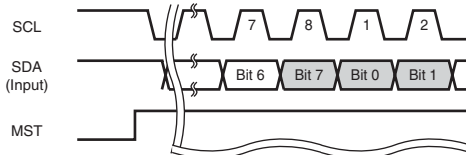

15.7 Usage Notes 272 Added

16.3.1 A/D Data Registers A to D (ADDRA to ADDR D) 276

There are four 16-bit read-only ADDR registers;
Therefore, byte access to ADDR should be done by reading the upper byte first then the lower one. ADDR is initialized to H'0000.

Figure 17.2 Block Diagram of Power-On Reset Circuit and Low-Voltage Detection Circuit 287

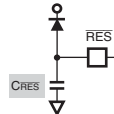

20.3 Electrical Characteristics (Masked ROM Version) 331

20.3 Electrical Characteristics (Masked ROM Version) [Preliminary]
The guarantee value for the electrical characteristics of masked ROM version is preliminary.
20.3.1 Power Supply Voltage and Operating Ranges

Item

Page Revision (See Manual for Details)

Table 20.13 AC
Characteristics

339

Item	Symbol	Values		
		Min.	Typ.	Max.
On-chip oscillator oscillation frequency	f _{RC}	7.6	8.0	8.4
		9.4	10.0	10.6

Table A.1 Instruction Set

353

- Arithmetic instructions

Mnemonic	Operand Size	Addressing Mode and Instruction Length (bytes)							Operation	Condition Code					No. of States ¹	
		#Rn	Rn	@Rn	@(d, ERn)	@-ERn/@ERn	@aa	@(d, PC)		@@aa	1	H	N	Z	O	Normal
ADD	ADD, #imm8, Rd	2							Rd ← Rd + imm8							
INC	INC, #2, ERn	2							ERn ← ERn + 2							
DAA	DAA, Rd	2							Rd ← decimal adjust							

Appendix C Product Code Lineup

395

Product Type	Model Marking	Package Code
H8/36912 Flash memory version	HD64F36912GFH	LQFP-32 (FP-32A)
	HD64F36912GTP	SOP-32 (FP-32D)
	HD64F36912GP	SDIP-32 (32P4B)
Masked ROM version	HD64336912G(***) FH	LQFP-32 (FP-32A)
	HD64336912G(***) TP	SOP-32 (FP-32D)
	HD64336912G(***) P	SDIP-32 (32P4B)
H8/36911 Masked ROM version	HD64336911G(***) FH	LQFP-32 (FP-32A)
	HD64336911G(***) TP	SOP-32 (FP-32D)
	HD64336911G(***) P	SDIP-32 (32P4B)
H8/36902 Flash memory version	HD64F36902GFH	LQFP-32 (FP-32A)
	HD64F36902GTP	SOP-32 (FP-32D)
	HD64F36902GP	SDIP-32 (32P4B)
Masked ROM version	HD64336902G(***) FH	LQFP-32 (FP-32A)
	HD64336902G(***) TP	SOP-32 (FP-32D)
	HD64336902G(***) P	SDIP-32 (32P4B)
H8/36901 Masked ROM version	HD64336901G(***) FH	LQFP-32 (FP-32A)
	HD64336901G(***) TP	SOP-32 (FP-32D)
	HD64336901G(***) P	SDIP-32 (32P4B)
H8/36900 Masked ROM version	HD64336900G(***) FH	LQFP-32 (FP-32A)
	HD64336900G(***) TP	SOP-32 (FP-32D)
	HD64336900G(***) P	SDIP-32 (32P4B)

Figure D.3 32P4B Package Dimension

Package Code	32P4B
JEDEC	—
JEITA	—
Mass (reference value)	2.2

Index

A		
A/D converter	273	
A/D conversion time	280	
External trigger input	281	
Sample-and-hold circuit	280	
Scan mode	279	
Single mode	279	
Acknowledge	255	
Address break	63	
Addressing modes		
Absolute address	33	
Immediate	34	
Memory indirect	34	
Program-counter relative	34	
Register direct	32	
Register indirect	33	
Register indirect with displacement	33	
Register indirect with post-increment	33	
Register indirect with pre-decrement	33	
B		
Bit Synchronous Circuit	271	
C		
Clock pulse generators		
System Prescaler S	83	
Clocked Synchronous Serial Format	263	
Condition field	31	
Condition-code register (CCR)	16	
CPU	11	
E		
Effective address	35	
Effective address extension	31	
Exception handling	47	
Reset exception handling	54	
Stack status	58	
Trap instruction	47	
F		
Flash memory	97	
Boot mode	102	
Boot program	102	
Erase/erase-verify	109	
Erasing units	97	
Error protection	112	
Hardware protection	112	
Program/program-verify	107	
Programming units	97	
Programming/erasing in user program mode	106	
Software protection	112	
G		
General registers	15	
I		
I/O ports	117	
I/O port block diagrams	379	
I ² C Bus Format	254	
I ² C Bus Interface 2 (IIC2)	239	
Instruction set	21	
Arithmetic operations instructions	23	
Bit Manipulation instructions	26	
Block data transfer instructions	30	
Branch instructions	28	
Data Transfer instructions	22	
Logic Operations instructions	25	

Shift Instructions	25
System control instructions.....	29
Internal power supply step-down circuit.....	299
Interrupt	
Internal interrupts	56
Interrupt response time	59
IRQ3 to IRQ0 interrupts.....	55
NMI interrupt.....	55
WKP5 to WKP0 interrupts	55

L

Low-voltage detection circuit.....	285
LVDI	293, 295
LVDI (interrupt by low voltage detect) circuit.....	293, 295
LVDR	292
LVDR (reset by low voltage detect) circuit.....	292

M

Memory map	12
Module standby function	95

N

Noise Canceler.....	265
---------------------	-----

O

On-board programming modes.....	102
Operation field.....	30

P

Package.....	2
Package dimensions.....	396

Power-down modes.....	85
Sleep mode.....	93
Standby mode	93
Subsleep mode	94
Power-on reset	285
Power-on reset circuit	291
Product code lineup	395
Program counter (PC).....	16
PWM operation.....	176

R

Register

ABRKCR	64, 304, 308, 310
ABRKSR	66, 304, 308, 310
ADCR	278, 303, 307, 310
ADCSR.....	276, 303, 307, 310
ADDRA	275, 303, 307, 310
ADDRB	275, 303, 307, 310
ADDRC	275, 303, 307, 310
ADDRD	275, 303, 307, 310
BARH	66, 304, 308, 310
BARL.....	66, 304, 308, 310
BDRH	66, 304, 308, 310
BDRL.....	66, 304, 308, 310
BRR	206, 303, 307, 310
EBR1.....	101, 303, 307, 309
FENR	101, 303, 307, 309
FLMCR1	99, 303, 307, 309
FLMCR2.....	100, 303, 307, 309
GRA.....	171, 303, 306, 309
GRB.....	171, 303, 306, 309
GRC.....	171, 303, 307, 309
GRD.....	171, 303, 307, 309
ICCR1	242, 302, 306, 309
ICCR2	245, 302, 306, 309
ICDRR	253, 302, 306, 309
ICDRS.....	253
ICDRT	253, 302, 306, 309
ICIER.....	248, 302, 306, 309

ICMR	246, 302, 306, 309
ICSR	250, 302, 306, 309
IEGR1	49, 304, 308, 311
IEGR2	50, 304, 308, 311
IENR1	50, 304, 308, 311
IRR1	52, 305, 308, 311
IWPR	53, 305, 308, 311
LVDCR	288, 302, 306, 309
LVDSR	290, 302, 306, 309
MSTCR1	89, 305, 308, 311
MSTCR2	90, 305, 308, 311
PCR1	119, 304, 308, 311
PCR2	122, 304, 308, 311
PCR5	125, 304, 308, 311
PCR7	128, 304, 308, 311
PCR8	131, 304, 308, 311
PDR1	119, 304, 308, 310
PDR2	122, 304, 308, 310
PDR5	126, 304, 308, 310
PDR7	129, 304, 308, 310
PDR8	131, 304, 308, 310
PDRB	134, 304, 308, 310
PMR1	118, 304, 308, 311
PMR5	125, 304, 308, 311
PUCR1	120, 304, 308, 310
PUCR5	126, 304, 308, 310
RDR	200, 303, 307, 310
RSR	200
SAR	252, 302, 306, 309
SCR3	202, 303, 307, 310
SMR	201, 303, 307, 310
SPMR	211, 303, 307, 310
SSR	204, 303, 307, 310
SYSCR1	86, 304, 308, 311
SYSCR2	88, 304, 308, 311
TCB1	141, 302, 306, 309
TCNT	171, 306, 309
TCNTV	147, 303, 307, 310
TCORA	148, 303, 307, 310

TCORB	148, 303, 307, 310
TCRV0	148, 303, 307, 309
TCRV1	151, 303, 307, 310
TCRW	164, 302, 306, 309
TCSRVD	150, 303, 307, 310
TCSRWD	192, 303, 307, 310
TCWD	194, 304, 307, 310
TDR	200, 303, 307, 310
TIERW	165, 302, 306, 309
TIOR0	168, 303, 306, 309
TIOR1	169, 303, 306, 309
TLB1	141
TMB1	140, 302, 306, 309
TMRW	163, 302, 306, 309
TMWD	194, 304, 307, 310
TSR	200
TSRW	166, 302, 306, 309
Register field	30

S

Serial communication interface 3

(SCI3)	197
Asynchronous mode	212
Bit rate	206
Break	236
Clocked synchronous mode	219
Framing error	216
Multiprocessor communication function	227
Overrun error	216
Parity error	216
Slave address	255
Stack pointer (SP)	16
Start condition	255
Stop condition	255
System clocks	69

T

Timer B1.....	139
Auto-reload timer operation	142
Interval timer operation	142
Timer V	145
Timer W	159
Transfer Rate	244

V

Vector address.....	47
---------------------	----

W

Watchdog timer.....	191
---------------------	-----

**Renesas 16-Bit Single-Chip Microcomputer
Hardware Manual
H8/36912 Group, H8/36902 Group**

Publication Date: Rev.1.00, Nov. 07, 2003
Rev.3.00, Sep. 14, 2006

Published by: Sales Strategic Planning Div.
Renesas Technology Corp.

Edited by: Customer Support Department
Global Strategic Communication Div.
Renesas Solutions Corp.

Renesas Technology Corp. Sales Strategic Planning Div. Nippon Bldg., 2-6-2, Ohte-machi, Chiyoda-ku, Tokyo 100-0004, Japan



RENESAS SALES OFFICES

<http://www.renesas.com>

Refer to "<http://www.renesas.com/en/network>" for the latest and detailed information.

Renesas Technology America, Inc.

450 Holger Way, San Jose, CA 95134-1368, U.S.A
Tel: <1> (408) 382-7500, Fax: <1> (408) 382-7501

Renesas Technology Europe Limited

Dukes Meadow, Millboard Road, Bourne End, Buckinghamshire, SL8 5FH, U.K.
Tel: <44> (1628) 585-100, Fax: <44> (1628) 585-900

Renesas Technology (Shanghai) Co., Ltd.

Unit 204, 205, AZIA Center, No.1233 Lujiazui Ring Rd, Pudong District, Shanghai, China 200120
Tel: <86> (21) 5877-1818, Fax: <86> (21) 6887-7898

Renesas Technology Hong Kong Ltd.

7th Floor, North Tower, World Finance Centre, Harbour City, 1 Canton Road, Tsimshatsui, Kowloon, Hong Kong
Tel: <852> 2265-6688, Fax: <852> 2730-6071

Renesas Technology Taiwan Co., Ltd.

10th Floor, No.99, Fushing North Road, Taipei, Taiwan
Tel: <886> (2) 2715-2888, Fax: <886> (2) 2713-2999

Renesas Technology Singapore Pte. Ltd.

1 Harbour Front Avenue, #06-10, Keppel Bay Tower, Singapore 098632
Tel: <65> 6213-0200, Fax: <65> 6278-8001

Renesas Technology Korea Co., Ltd.

Kukje Center Bldg. 18th Fl., 191, 2-ka, Hangang-ro, Yongsan-ku, Seoul 140-702, Korea
Tel: <82> (2) 796-3115, Fax: <82> (2) 796-2145

Renesas Technology Malaysia Sdn. Bhd

Unit 906, Block B, Menara Amcorp, Amcorp Trade Centre, No.18, Jalan Persiaran Barat, 46050 Petaling Jaya, Selangor Darul Ehsan, Malaysia
Tel: <603> 7955-9390, Fax: <603> 7955-9510



H8/36912 Group, H8/36902 Group Hardware Manual



Renesas Electronics Corporation

1753, Shimonumabe, Nakahara-ku, Kawasaki-shi, Kanagawa 211-8668 Japan

REJ09B0105-0300