

THIS DRAWING IS UNPUBLISHED. RELEASED FOR PUBLICATION, 19 .
 © COPYRIGHT 19 BY AMP INCORPORATED. ALL RIGHTS RESERVED.

LOC	DIST	REVISIONS					
		P	LTR	DESCRIPTION	DATE	DWN	APVD
AF	50		A	REL PER 0G1A-0348-98	10/2/98	JR	SH

- CONTINUOUS STRIP ON REELS.
- WIRE SIZE [#20-#16] AWG.
- INSULATION RANGE 1.52-2.54 [.060-.100] DIA.
- MATING TAB THK 0.51±0.025 [.020±.001].

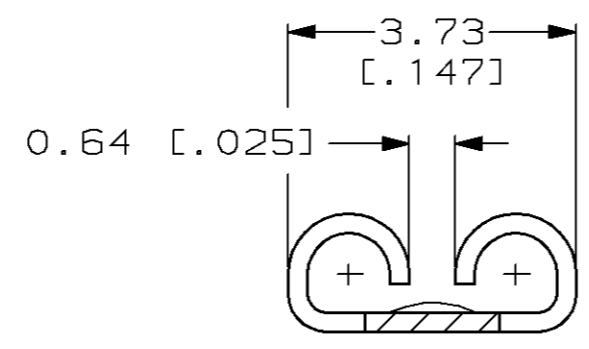
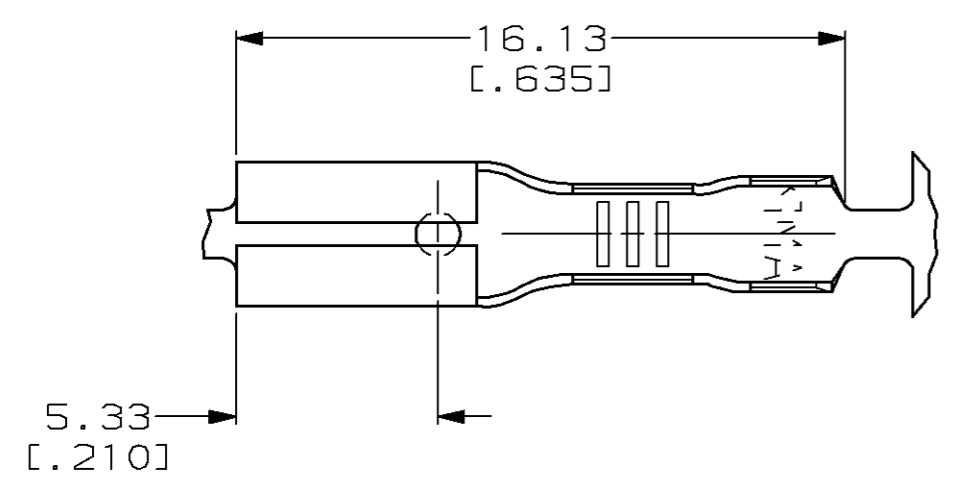

VIEW A-A
SCALE 10:1

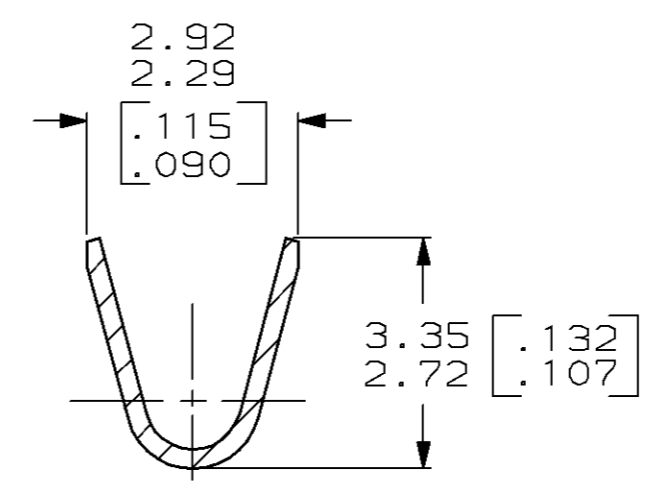
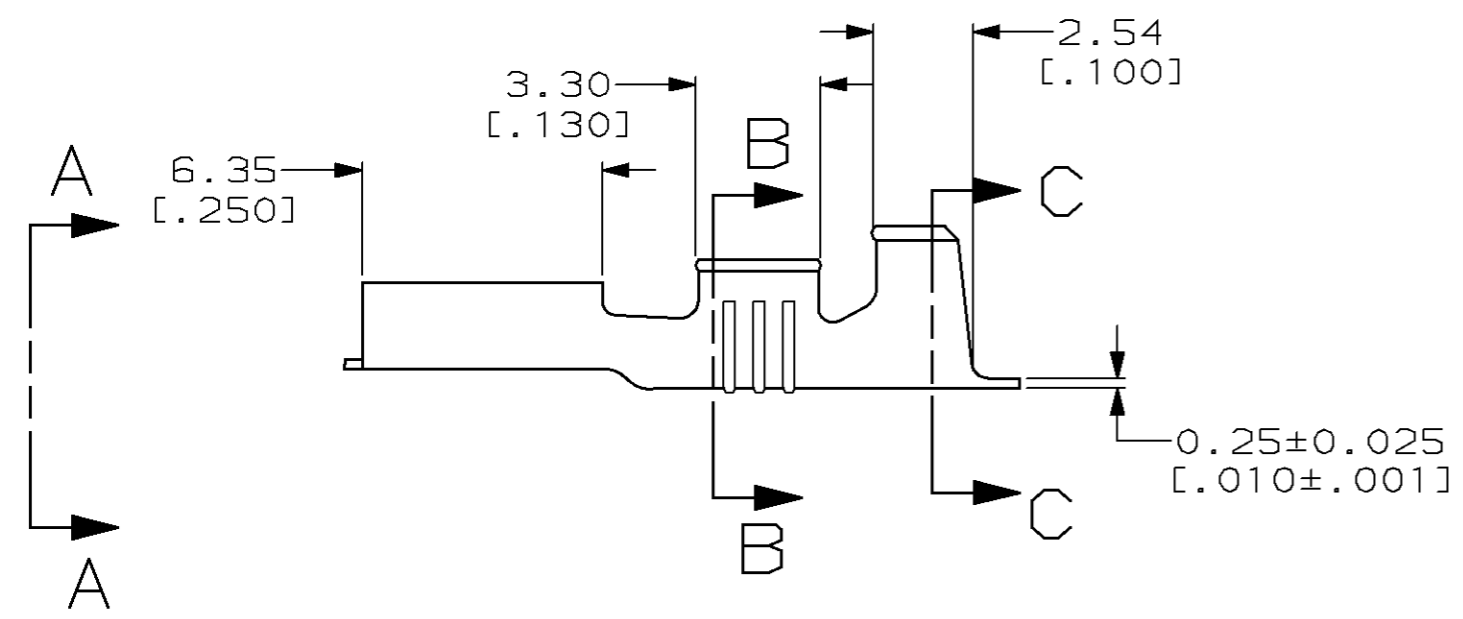

SECTION B-B
SCALE 10:1

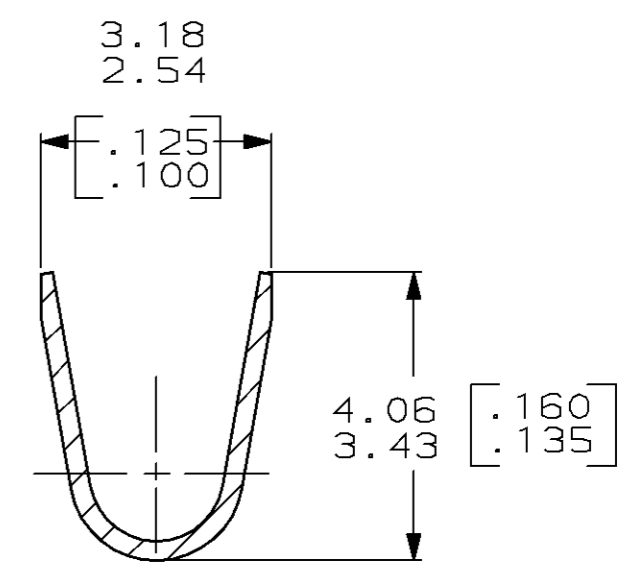

SECTION C-C
SCALE 10:1

1217102-1
PART NO.

THIS DRAWING IS A CONTROLLED DOCUMENT.		DWN	JR RUTH	7/27/98	AMP AMP Incorporated Harrisburg, PA 17105-3608												
DIMENSIONS: MM [INCHES]		CHK	MS FEHER	7/27/98													
TOLERANCES UNLESS SPECIFIED OTHERWISE		APVD	G YETTER	7/27/98													
<table border="1"> <tr><td>0 PLC</td><td>±-</td></tr> <tr><td>1 PLC</td><td>±-</td></tr> <tr><td>2 PLC</td><td>±0.25 [.010]</td></tr> <tr><td>3 PLC</td><td>±-</td></tr> <tr><td>4 PLC</td><td>±-</td></tr> <tr><td>ANGLES</td><td>±-</td></tr> </table>		0 PLC	±-	1 PLC		±-	2 PLC	±0.25 [.010]	3 PLC	±-	4 PLC	±-	ANGLES	±-	PRODUCT SPEC	-	NAME
0 PLC	±-																
1 PLC	±-																
2 PLC	±0.25 [.010]																
3 PLC	±-																
4 PLC	±-																
ANGLES	±-																
MATERIAL	082 C.R.STEEL	FINISH	0.00381 [.000150] MIN NICKEL	APPLICATION SPEC	-	SIZE	A3	CAGE CODE	00779	DRAWING NO	C= 1217102	RESTRICTED TO	-				
CUSTOMER DRAWING				WEIGHT	-	SCALE	5:1	SHEET	1 OF 1	REV	A						