

ATLANTIC VERSION TERMINATOR INTERFACE ADAPTER	PART NUMBER	REVISION	DESCRIPTION	FEED TYPE	APPLICATOR STYLE CONVERSION CHART						
					CONVERT TO	PART NUMBERS REQUIRED					
	2266418-2	A	FINE CRIMP HEIGHT ADJUST	PNEUMATIC	-	-	-	-	-	-	
	2266418-5	A	FINE CRIMP HEIGHT ADJUST	SERVO LATCH PLATE ⁴	SERVO LATCH PLATE	2119951-1	-	8-2266418-5	1901094-3	-	2168400-6 (QUANTITY 2)
					SMART APPLICATOR	2161326-1	-	8-2266418-4	-	-	-
	2266418-6	A	NON-CRIMP HEIGHT ADJUST	SERVO LATCH PLATE ⁴	PNEUMATIC FEED	2119950-1	1338685-1	5-18022-5	2119641-1	2119799-1	2063440-1
					-	-	-	-	-	-	-
	2266418-7	A	FINE CRIMP HEIGHT ADJUST	NONE	-	-	-	-	-	-	-
	7-2266418-7	A	CRIMP TOOLING KIT	-	-	-	-	-	-	-	-

APPLICATOR DATA		
CRIMP	SIZE	TYPE
WIRE	3.30 mm [.130]	F
INSUL	3.94 mm [.155]	O

APPLICATOR INSTRUCTIONS 408-10389

TERMINAL DATA: KOSTAL TERMINAL		KOSTAL CRIMP SPECIFICATION	
TERMINAL NAME: SLK 2.8			
WIRE STRIP LENGTH		INSULATION DIAMETER RANGE	
5.00-5.60 mm [.197-.220 IN]		Ø3.40-3.70 mm [.134-.146 IN]	
TERMINAL APPLICATION SPECIFICATION		00074173	
TERMINALS APPLIED ¹⁰			
TE TERMINAL	KOSTAL TERMINAL	TE TERMINAL	KOSTAL TERMINAL
1572233-1	22124499720	1572899-1	10124499110
1572233-2	22125499720	1572899-2	10140499110
1572233-3	22140499720	1572899-3	10125499110

WIRE SIZE	CRIMP HEIGHT mm [INCH]	CRIMP HEIGHT REFERENCE SETTING
4.00mm2	1.95 +/- 0.05 [.077 +/- .002]	7.8

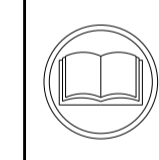

- ¹ RECOMMENDED SPARE PARTS
- ² GREASE BEARING SURFACES LIGHTLY
- 3. LUBRICATE DAILY PER THE APPLICATOR INSTRUCTION SHEET SUPPLIED WITH THE APPLICATOR.
- ⁴ APPLICATOR SPECIFIC DATA TO BE ENTERED INTO BLANK MEMORY CHIP AT ASSEMBLY. SEE BELOW FOR PART NUMBER:
 PNEUMATIC FEED WITH "SMART APPLICATOR" CONVERSION: 8-2266418-4
 SERVO FEED WITH "FINE CRIMP HEIGHT ADJUST": 8-2266418-5
 SERVO FEED WITH "NON-CRIMP HEIGHT ADJUST": 8-2266418-6
- 5. ADJUSTMENT OF THE STRIPPER MAY BE REQUIRED WHEN MOVING THE APPLICATOR BETWEEN BENCH AND LEADMAKER APPLICATIONS.
- ⁶ APPLY PART NUMBER 1-23419-5 LOCTITE TO THREADS OF ITEMS 62. APPLY PART NUMBER 2-23419-6 LOCTITE TO THREADS OF ITEM 242. FOR -6 ONLY APPLY PART NUMBER 1-23419-5 LOCTITE TO THREADS OF ITEMS 37.
- ⁷ GREASE THREADS, GROOVE AND O-RING ON ITEMS 35 & 252.
- ⁸ MAGNET, ITEM 166 MUST BE ORIENTED CORRECTLY IN ORDER TO PROPERLY ACTUATE THE COUNTER.
- ⁹ CRIMP HEIGHT REFERENCE SETTING WAS THE SETTING USED WHEN THE APPLICATOR WAS QUALIFIED AT THE FACTORY. ADJUSTMENT MAY BE NECESSARY WHEN RUNNING APPLICATOR IN THE FIELD.
- ¹⁰ TERMINAL PITCH NOT COMPATIBLE WITH MECHANICAL FEED.
- ¹¹ TO CONVERT THE APPLICATOR TO A NON-CARRIER CUTTING STYLE, REMOVE ITEM 13 AND ATTACH TO THE LOCATION ON THE BACK SIDE OF THE HOUSING. REFER TO INSTRUCTION SHEET FOR ADDITIONAL INFORMATION.
- ¹² WHEN ASSEMBLING A NON CRIMP HEIGHT ADJUST APPLICATOR (-6) USE SHIMS FROM ITEM 260 TO ACHIEVE A NOMINAL SHIM HEIGHT OF 3.85.
- ¹³ FEED MUST BE SET TO USE THE SLOT IN THE CARRIER STRIP.

***WARNING**
 ON INSTALLATION, SET WIRE DISC, ITEM 40 TO LARGEST WIRE SIZE SETTING. USE OF SETTINGS BELOW MINIMUM REQUIRED CRIMP HEIGHT SETTING WILL CAUSE DAMAGE TO CRIMP TOOLING.

ATLANTIC VERSION
 Shown on sheets 1 of 4 & 2 of 4
 (Pacific version shown on sheets 3 of 4 & 4 of 4)

SET UP GAUGE	LOC	DIST	REVISIONS					
2119599-1	A	66	P	LTN	DESCRIPTION	DATE	OWN	APVD
			A		RELEASED	02SEP2014	RK	GB
			A1		ECR-14-015266	15OCT2014	KH	UG

-	-	1	-	-	2119957-2	APPLICATOR SHIM PACK	260
-	1	1	1	1	1803078-3	SPACER, PRECISION	259
-	1	-	1	1	8-21084-0	O-RING, .676 ID, .070 DIA. MAT.	252
-	-	-	-	1	2119640-1	PUSH ROD, AIR FEED	250
-	-	-	-	1	2079988-1	BUSHING, LCH5-12, MISUMI	249
-	-	-	-	1	2119641-1	FEED CAM, AIR FEED	248
-	1	-	1	1	2119798-1	DETENT PIN	247
-	1	-	1	1	1-22279-3	SPRING, COMPRESSION	246
-	-	1	-	-	2161314-1	RAM, STEPPED, ATLANTIC, SF, NON-ADJ	245
-	1	1	1	1	2119082-4	CAM, SNAIL, INSULATION ADJUSTMENT	244
-	1	1	1	1	2079764-1	WASHER, WAVE SPRING, CREST-TO-CREST	243
-	1	1	1	1	2119083-1	RETAINER, INSULATION DIAL	242
-	1	1	1	1	7-18023-7	SCR, SKT HD CAP M3 X 4.0	241
-	-	2	2	-	2168400-6	SHCS, LOW HEAD, RoHS, M5 X 16	240
-	-	-	-	1	2063440-1	AIR FEED MODULE	238
-	-	1	1	-	2119740-2	TAG, IDENTIFICATION	213
-	-	1	1	-	1901094-3	SPACER, FEEDER	198
-	-	-	-	2	21045-3	RING, RETAIN, EXTERN, 3/16 CRESCENT	172
-	1	1	1	1	994969-1	MAGNET, RARE EARTH HIGH ENERGY	166
-	REF	REF	REF	REF	994970-2	COUNTER, MAGNETIC	164
-	-	-	-	1	240638-1	SPRING, FEED FINGER	163
-	-	-	-	1	3-23627-7	PIN, RETAIN, GRVD, 3/16 X .854	137
-	-	-	-	1	2119799-1	HOLDER, FEED FINGER, AF	136
-	-	REF	REF	-	SEE NOTE 4	MEMORY CHIP, PROGRAMMED	135
-	-	1	1	-	1633743-1	SERVO FEED LATCH ASM	133
-	-	REF	REF	-	2119944-1	FEED FINGER ASSEMBLY, SF	117
-	1	1	1	1	1-455888-9	SPACER, CRIMPER	82
-	1	1	1	1	2119956-1	DOCUMENTATION PACKAGE	71
-	1	1	1	1	2119791-9	DEPRESSOR, WIRE	70
-	1	-	-	1	2119740-1	TAG, IDENTIFICATION	67
-	2	2	2	2	2168078-1	SCREW, DRIVE, RH, RoHS, 2 x .188	66
-	1	-	1	1	2119793-1	LIMITER, ADJUSTMENT BOLT	63
-	3	-	3	3	992763-5	SCR, SET, SOC, CONE POINT, M3 x 4.0	62
-	1	1	1	1	2079383-4	SCR, BHSC, RoHS (M4 X 8)	60
-	-	-	-	1	5-18022-5	SCR, HEX HD CAP, M4 X 6.0	59
-	-	-	-	1	1338685-1	PAWL, FEED	56
-	4	4	4	4	2168400-1	SHCS, LOW HEAD, RoHS, M4 X 12	54
-	2	2	2	2	1-2168083-0	SCR, SKT HD CAP, RoHS, M4 X 10	53
-	1	1	1	1	5018030-1	NUT, HEX, REG, RoHS, M3	52
-	1	1	1	1	811242-5	BUMPER, HOLD DOWN	51
-	1	1	1	1	690753-2	SPACER, TONKER	50
-	-	-	-	1	18023-9	SCR, SKT HD CAP M4 X 6.0	49
-	1	1	1	1	2119656-9	APPLICATOR BASIC ASSEMBLY, SF	46
-	1	-	1	1	2161311-1	RAM, STEPPED, AMP STYLE, SIDE FEED	44
-	1	1	1	1	1-2079383-5	SCR, BHSC, RoHS (M8 X 40)	41
-	1	-	1	1	2119645-1	DISC, NUMBERED FA WIRE ADJUSTMENT	40
-	1	-	1	1	2119957-1	APPLICATOR SHIM PACK	39
-	1	1	1	1	2119644-2	RAM WASHER, PRECISION	38
-	1	1	1	1	2119085-1	FA HEAD, ATLANTIC STYLE	37
-	1	-	1	1	2119092-1	BOLT, ADJUSTMENT	35
-	1	1	1	1	1752356-9	SUPPORT, TERMINAL	34
-	2	2	2	2	2079383-5	SCR, BHSC, RoHS (M4 X 20)	33
-	1	1	1	1	2161328-1	HEX HEAD, FLANGED, M5 x 8mm LONG	32
-	1	1	1	1	1320908-7	SPACER, STRIP GUIDE	30
-	1	1	1	1	2119959-2	ASSEMBLY, STRIP GUIDE	29
-	1	1	1	1	455888-3	SPACER, CRIMPER	28
-	1	1	1	1	1320928-6	STRIP GUIDE	24
-	1	1	1	1	2168083-2	SCR, SKT HD CAP, RoHS, M4 X 8.0	21
-	2	2	2	2	1-18028-2	WASHER, FLAT, REG M4	20
-	1	1	1	1	2119533-1	STRIPPER, SIDE FEED	19
-	1	1	1	1	2119806-1	INSERT, SHEAR	13
-	1	1	1	1	3-22280-3	SPRING, COMPRESSION	12
-	1	1	1	1	1-356885-4	STOP, SHEAR	11
-	1	1	1	1	2119805-1	SHEAR HOLDER, FRONT	10
-	1	1	1	1	318707-1	FLOATING SHEAR, FRONT	9
-	1	1	1	1	1633136-1	ANVIL, COMBINATION .130	8
-	-	-	-	-	-	-	7
-	-	-	-	-	-	-	6
-	1	1	1	1	2119757-8	DEPRESSOR, SHEAR	5
-	1	1	1	1	238011-3	BLOCK, CRIMPER SPACER	4
-	1	1	1	1	4-1803018-2	CRIMPER, INSULATION O	3
-	1	1	1	1	455888-8	SPACER, CRIMPER	2
-	1	1	1	1	2-1752057-0	CRIMPER, WIRE PREMIUM, STEPPED	1

DIMENSIONS:		TOLERANCES UNLESS OTHERWISE SPECIFIED:		OWN	CHK	DATE	TE Connectivity	
mm	0 PLC ±.5	1 PLC ±.5	2 PLC ±.13	Y. YIN	G. BAILEY	22 JUL 2014	Harrisburg, PA 17105-3608	
	3 PLC ±.013	4 PLC ±.0001	ANGLES ±.0001	U. GUO		22 JUL 2014	NAME Ocean Side Feed Applicator	
MATERIAL	FINISH	WEIGHT	SCALE	Customer Accessible Production Drawing		1:2	SHEET 1 of 4	REV A1

LOC		DIST		REVISIONS			
A	66	P	LTM	DESCRIPTION	DATE	DWN	APVD
		-	-	SEE SHEET 1	-	-	-

FEED TYPE

PNEUMATIC

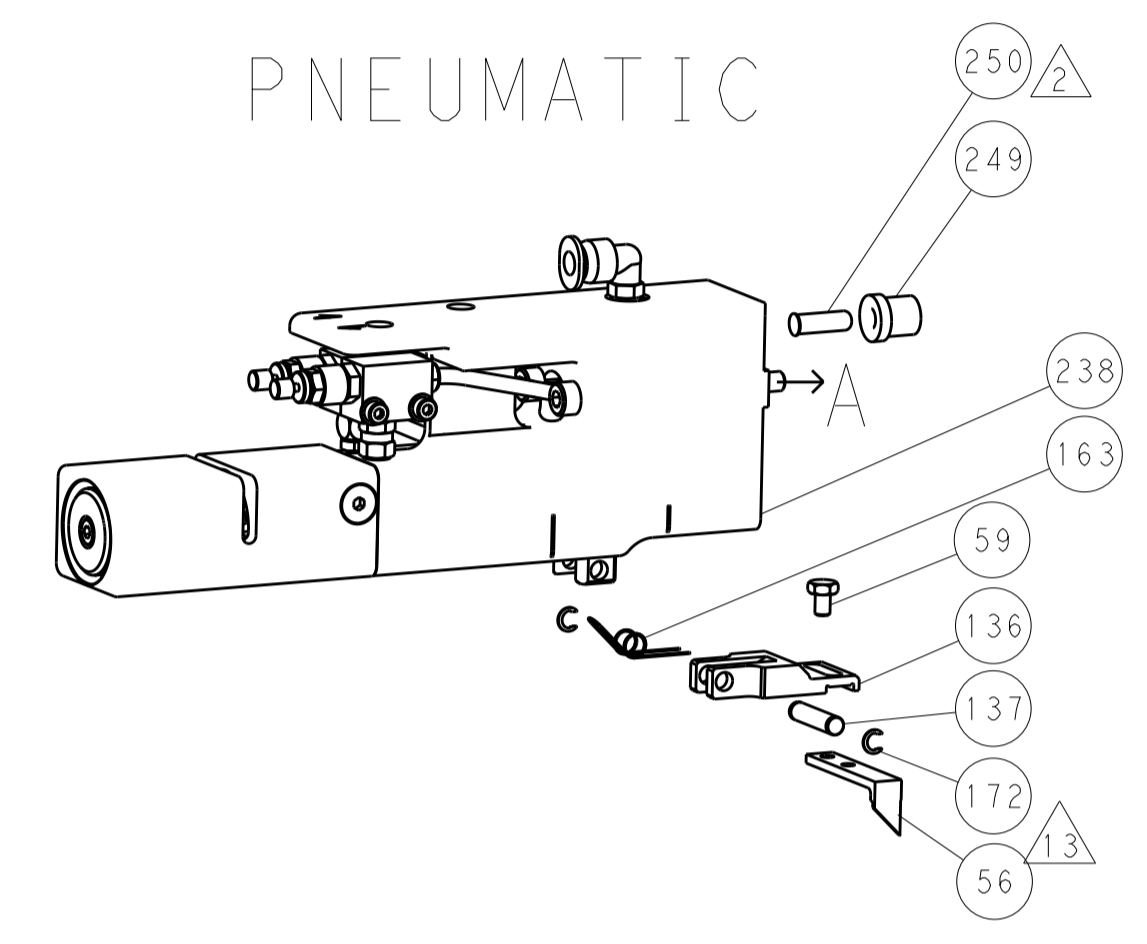

SERVO LATCH PLATE

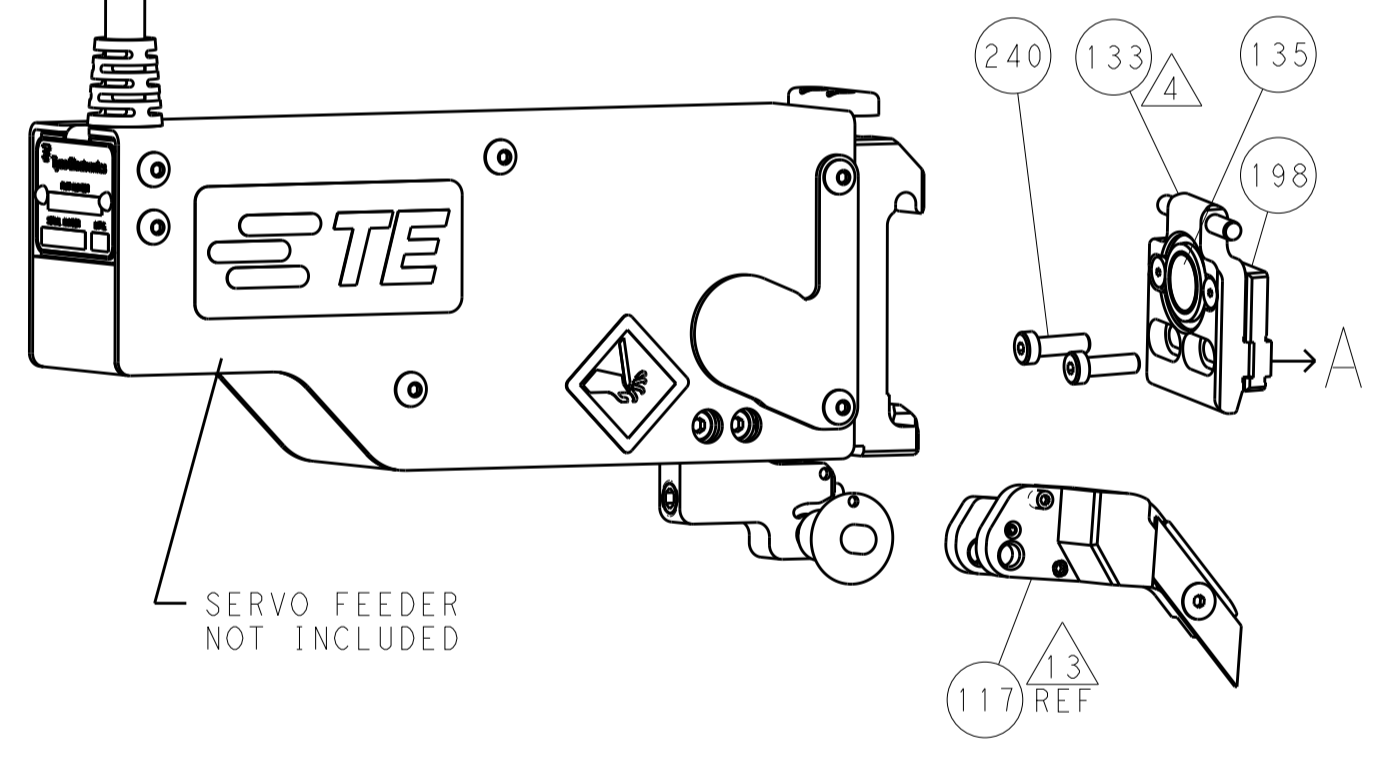

CAM POSITION

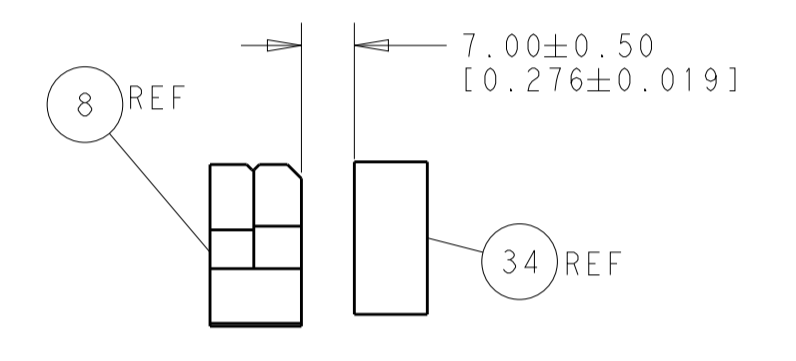
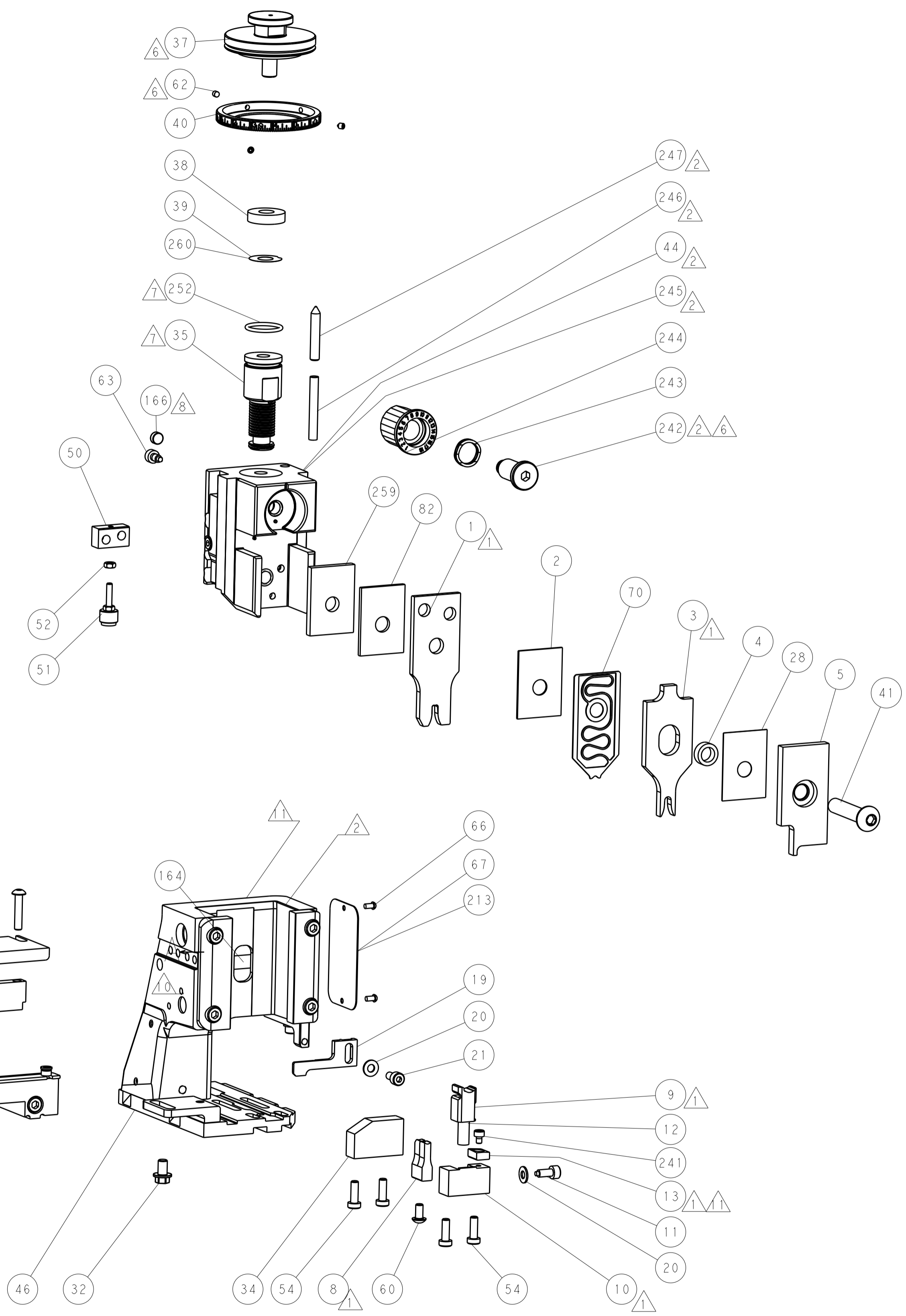
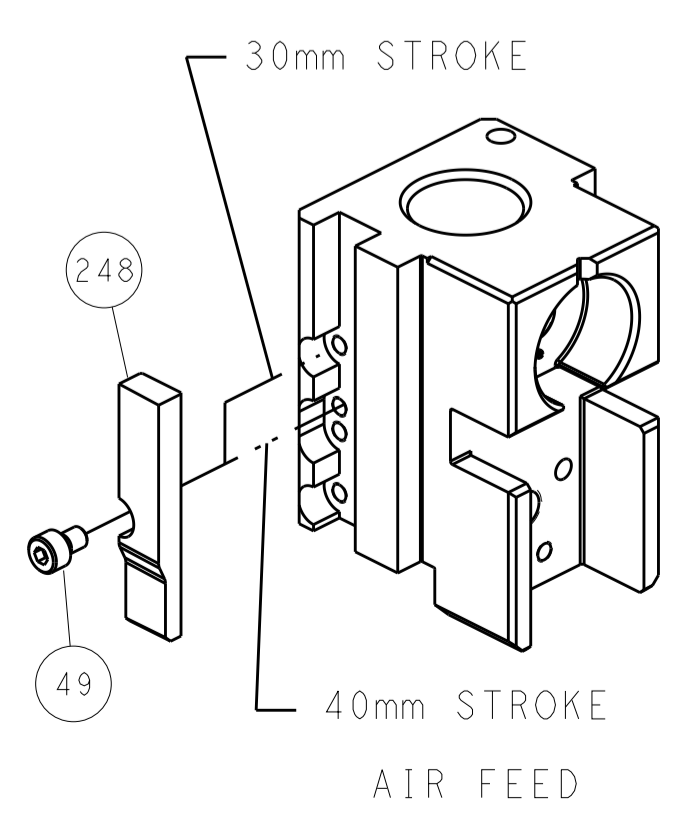

TERMINAL SUPPORT LOCATION

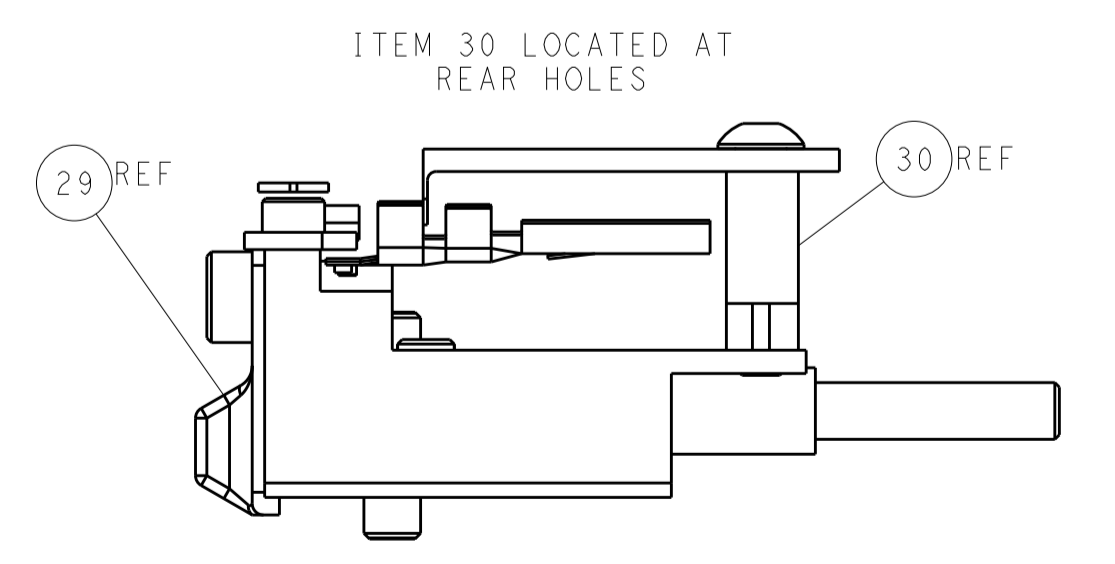

FEED TRACK POSITION GUIDE BY INSULATION BARREL

ATLANTIC VERSION
 Shown on sheets 1 of 4 & 2 of 4
 (Pacific version shown on sheets 3 of 4 & 4 of 4)

DIMENSIONS:		TOLERANCES UNLESS OTHERWISE SPECIFIED:		DWN T. YIN 22JUL2014		TE Connectivity Harrisburg, PA 17105-3608	
mm	0 PLC ±0.5	1 PLC ±0.5	2 PLC ±0.13	3 PLC ±0.013	4 PLC ±0.0001	NAME Ocean Side Feed Applicator	
MATERIAL:		FINISH:		APVD G. BAILEY 22JUL2014		RESTRICTED TO	
Customer Accessible Production Drawing		SCALE 1:2		SHEET 2 OF 4		REV A1	

PACIFIC VERSION TERMINATOR INTERFACE ADAPTER	PART NUMBER	REVISION	DESCRIPTION	FEED TYPE	CONVERT TO	PART NUMBERS REQUIRED					
	2-2266418-2	A	FINE CRIMP HEIGHT ADJUST	PNEUMATIC	SERVO LATCH PLATE	2119951-1	-	8-2266418-5	1901094-3	-	2168400-6 (QUANTITY 2)
	2-2266418-5	A	FINE CRIMP HEIGHT ADJUST	SERVO LATCH PLATE ⁴	SMART APPLICATOR	2161326-1	-	8-2266418-4	-	-	-
	2-2266418-7	A	FINE CRIMP HEIGHT ADJUST	NONE	PNEUMATIC FEED	2119950-1	1338685-1	5-18022-5	2119641-2	2119799-1	2063440-1
	7-2266418-7	A	CRIMP TOOLING KIT	-	-	-	-	-	-	-	-

APPLICATOR DATA		
CRIMP WIRE	SIZE	TYPE
	3.30 mm [1.30]	F
INSUL	3.94 mm [1.55]	O
APPLICATOR INSTRUCTIONS 408-10389		

TERMINAL DATA: KOSTAL TERMINAL		KOSTAL CRIMP SPECIFICATION	
TERMINAL NAME: SLK 2.8			
WIRE STRIP LENGTH		INSULATION DIAMETER RANGE	
5.00-5.60 mm [1.97-.220 IN]		Ø3.40-3.70 mm [1.34-.146 IN]	
TERMINAL APPLICATION SPECIFICATION	00074173	-	-
TERMINALS APPLIED ¹⁰			
TE TERMINAL	KOSTAL TERMINAL	TE TERMINAL	KOSTAL TERMINAL
1572233-1	22124499720	1572899-1	10124499110
1572233-2	22125499720	1572899-2	10140499110
1572233-3	22140499720	1572899-3	10125499110

WIRE SIZE	CRIMP HEIGHT mm [INCH]	CRIMP HEIGHT REFERENCE SETTING
4.00mm2	1.95+/-0.05 [1.077+/-0.02]	7.8



- ¹ RECOMMENDED SPARE PARTS
- ² GREASE BEARING SURFACES LIGHTLY
- 3. LUBRICATE DAILY PER THE APPLICATOR INSTRUCTION SHEET SUPPLIED WITH THE APPLICATOR.
- ⁴ APPLICATOR SPECIFIC DATA TO BE ENTERED INTO BLANK MEMORY CHIP AT ASSEMBLY. SEE BELOW FOR PART NUMBER:
PNEUMATIC FEED WITH "SMART APPLICATOR" CONVERSION: 8-2266418-4
SERVO FEED WITH "FINE CRIMP HEIGHT ADJUST": 8-2266418-5
- 5. ADJUSTMENT OF THE STRIPPER MAY BE REQUIRED WHEN MOVING THE APPLICATOR BETWEEN BENCH AND LEADMAKER APPLICATIONS.
- ⁶ APPLY PART NUMBER 1-23419-5 LOCTITE TO THREADS OF ITEMS 62. APPLY PART NUMBER 2-23419-6 LOCTITE TO THREADS OF ITEM 242.
- ⁷ GREASE THREADS, GROOVE AND O-RING ON ITEMS 139 & 152.
- ⁸ MAGNET MUST BE ORIENTED CORRECTLY IN ORDER TO PROPERLY ACTUATE THE COUNTER.
- ⁹ CRIMP HEIGHT REFERENCE SETTING WAS THE SETTING USED WHEN THE APPLICATOR WAS QUALIFIED AT THE FACTORY. ADJUSTMENT MAY BE NECESSARY WHEN RUNNING APPLICATOR IN THE FIELD.
- ¹⁰ TERMINAL PITCH NOT COMPATIBLE WITH MECHANICAL FEED.
- ¹¹ TO CONVERT THE APPLICATOR TO A NON-CARRIER CUTTING STYLE, REMOVE ITEM 13 AND ATTACH TO THE LOCATION ON BACK SIDE OF THE HOUSING. REFER TO INSTRUCTION SHEET FOR ADDITIONAL INFORMATION.
- ¹² FEED MUST BE SET TO USE THE SLOT IN THE CARRIER STRIP.

***WARNING**
ON INSTALLATION, SET WIRE DISC, ITEM 40 TO LARGEST WIRE SIZE SETTING. USE OF SETTINGS BELOW MINIMUM REQUIRED CRIMP HEIGHT SETTING WILL CAUSE DAMAGE TO CRIMP TOOLING.

PACIFIC VERSION
Shown on sheets 3 of 4 & 4 of 4
(Atlantic version shown on sheets 1 of 4 & 2 of 4)

SET UP GAUGE	LOC	DIST	REVISIONS			
2119599-1	A	66	REV	DATE	BY	APPV
			-	SEE SHEET 1	-	-

REV	DATE	BY	APPV	DESCRIPTION	DATE	QTY	APV
-	1	1	1	1803078-3	SPACER, PRECISION		259
-	1	1	1	2119782-1	FINE ADJUST HEAD ASM, PACIFIC STYLE		251
-	-	-	1	2119640-1	PUSH ROD, AIR FEED		250
-	-	-	1	2079988-1	BUSHING, LCH5-12, MISUMI		249
-	1	1	1	1-22279-3	SPRING, COMPRESSION		246
-	1	1	1	2119082-4	CAM, SNAIL, INSULATION ADJUSTMENT		244
-	1	1	1	2079764-1	WASHER, WAVE SPRING, CREST-TO-CREST		243
-	1	1	1	2119083-1	RETAINER, INSULATION DIAL		242
-	1	1	1	7-18023-7	SCR, SKT HD CAP M3 X 4.0		241
-	-	2	-	2168400-6	SHCS, LOW HEAD, RoHS, M5 X 16		240
-	-	-	1	2063440-1	AIR FEED MODULE		238
-	-	1	-	2119740-2	TAG, IDENTIFICATION		213
-	-	1	-	1901094-3	SPACER, FEEDER		198
-	-	-	2	21045-3	RING, RETAIN, EXTERN, 3/16 CRESCENT		172
-	1	1	1	994969-1	MAGNET, RARE EARTH HIGH ENERGY		166
-	REF	REF	REF	994970-2	COUNTER, MAGNETIC		164
-	-	-	1	240638-1	SPRING, FEED FINGER		163
-	1	1	1	8-21084-1	O-RING, .801 ID, .070 DIA. MAT.		152
-	-	-	1	2119641-2	FEED CAM, AIR FEED		151
-	1	1	1	2119798-2	DETENT PIN		145
-	1	1	1	2079383-8	SCR, BHSC, RoHS (M4 X 16)		144
-	4	4	4	2168400-5	SHCS, LOW HEAD, RoHS, M4 X 20		143
-	-	-	-	2119653-2	FEED CAM, POST FEED		142
-	1	1	1	1-2119656-0	APPLICATOR BASIC ASSEMBLY, SF		141
-	1	1	1	2161312-1	RAM, STEPPED, ASIAN STYLE, SIDE FEED		140
-	1	1	1	2119092-2	BOLT, ADJUSTMENT		139
-	-	-	1	3-23627-7	PIN, RETAIN, GRVD, 3/16 X .854		137
-	-	-	1	2119799-1	HOLDER, FEED FINGER, AF		136
-	-	REF	-	SEE NOTE 4	MEMORY CHIP, PROGRAMMED		135
-	-	1	-	1633743-1	SERVO FEED LATCH ASM		133
-	-	REF	-	2119944-1	FEED FINGER ASSEMBLY, SF		117
-	1	1	1	1-455888-9	SPACER, CRIMPER		82
-	1	1	1	2119956-1	DOCUMENTATION PACKAGE		71
-	1	1	1	2119791-9	DEPRESSOR, WIRE		70
-	1	-	1	2119740-1	TAG, IDENTIFICATION		67
-	2	2	2	2168078-1	SCREW, DRIVE, RH, RoHS, 2 x .188		66
-	1	1	1	2119793-1	LIMITER, ADJUSTMENT BOLT		63
-	3	3	3	992763-5	SCR, SET, SOC, CONE POINT, M3 X 4.0		62
-	-	-	1	5-18022-5	SCR, HEX HD CAP, M4 X 6.0		59
-	-	-	1	1338685-1	PAWL, FEED		56
-	2	2	2	1-2168083-0	SCR, SKT HD CAP, RoHS, M4 X 10		53
-	1	1	1	5018030-1	NUT, HEX, REG, RoHS, M3		52
-	1	1	1	811242-5	BUMPER, HOLD DOWN		51
-	1	1	1	690753-2	SPACER, TONKER		50
-	-	-	1	18023-9	SCR, SKT HD CAP M4 X 6.0		49
-	1	1	1	1-2079383-5	SCR, BHSC, RoHS (M8 X 40)		41
-	1	1	1	2119645-1	DISC, NUMBERED FA WIRE ADJUSTMENT		40
-	1	1	1	2119957-1	APPLICATOR SHIM PACK		39
-	1	1	1	2119644-2	RAM WASHER, PRECISION		38
-	1	1	1	1752356-9	SUPPORT, TERMINAL		34
-	2	2	2	2079383-5	SCR, BHSC, RoHS (M4 X 20)		33
-	1	1	1	2161328-1	HEX HEAD, FLANGED, M5 X 8mm LONG		32
-	1	1	1	1320908-7	SPACER, STRIP GUIDE		30
-	1	1	1	2119959-2	ASSEMBLY, STRIP GUIDE		29
-	1	1	1	455888-3	SPACER, CRIMPER		28
-	1	1	1	1320928-6	STRIP GUIDE		24
-	1	1	1	2168083-2	SCR, SKT HD CAP, RoHS, M4 X 8.0		21
-	2	2	2	1-18028-2	WASHER, FLAT, REG M4		20
-	1	1	1	2119533-1	STRIPPER, SIDE FEED		19
-	1	1	1	2119806-1	INSERT, SHEAR		13
-	1	1	1	3-22280-3	SPRING, COMPRESSION		12
-	1	1	1	1-356885-4	STOP, SHEAR		11
-	1	1	1	2119805-1	SHEAR HOLDER, FRONT		10
-	1	1	1	318707-1	FLOATING SHEAR, FRONT		9
-	1	1	1	1633136-1	ANVIL, COMBINATION .130		8
-	-	-	-	-	-		7
-	-	-	-	-	-		6
-	1	1	1	2119757-8	DEPRESSOR, SHEAR		5
-	1	1	1	238011-3	BLOCK, CRIMPER SPACER		4
-	1	1	1	4-1803018-2	CRIMPER, INSULATION O		3
-	1	1	1	455888-8	SPACER, CRIMPER		2
-	1	1	1	2-1752057-0	CRIMPER, WIRE PREMIUM, STEPPED		1

DIMENSIONS:	TOLERANCES UNLESS OTHERWISE SPECIFIED:	OWN	CHK	APPV	DATE	NAME	PRODUCT SPEC	APPLICATION SPEC	SIZE	CAGE CODE	DRAWING NO	RESTRICTED TO
mm	0 PLC ±.5 1 PLC ±0.5 2 PLC ±0.13 3 PLC ±0.013 4 PLC ±0.001 ANGLES ±.1	Y. YIN	G. BAILEY	H. GUO	22 JUL 2014	TE Connectivity Harrisburg, PA 17105-3608			A1	00779	2266418	
Customer Accessible Production Drawing												
SCALE										1:2	SHEET 3 OF 4	

LOC		DIST		REVISIONS			
A	66	P	LTM	DESCRIPTION	DATE	DMN	APVD
		-		SEE SHEET 1			

FEED TYPE PNEUMATIC

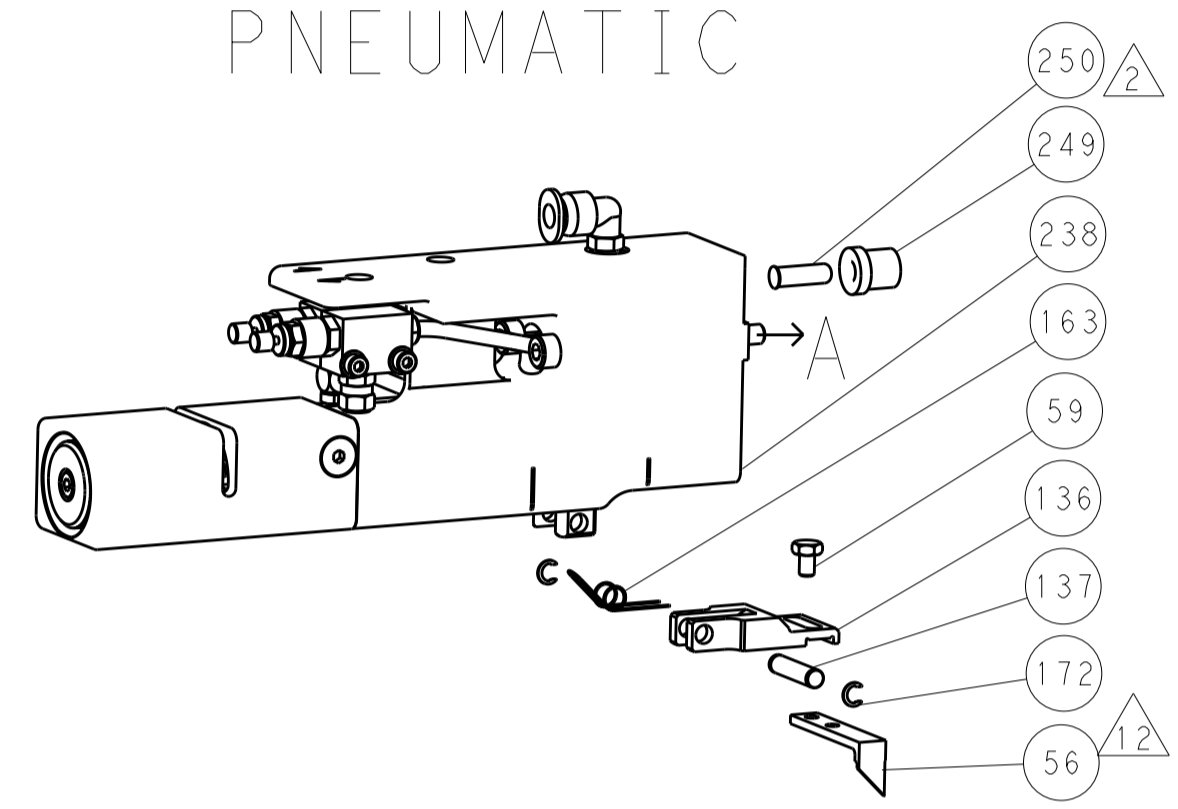

SERVO LATCH PLATE

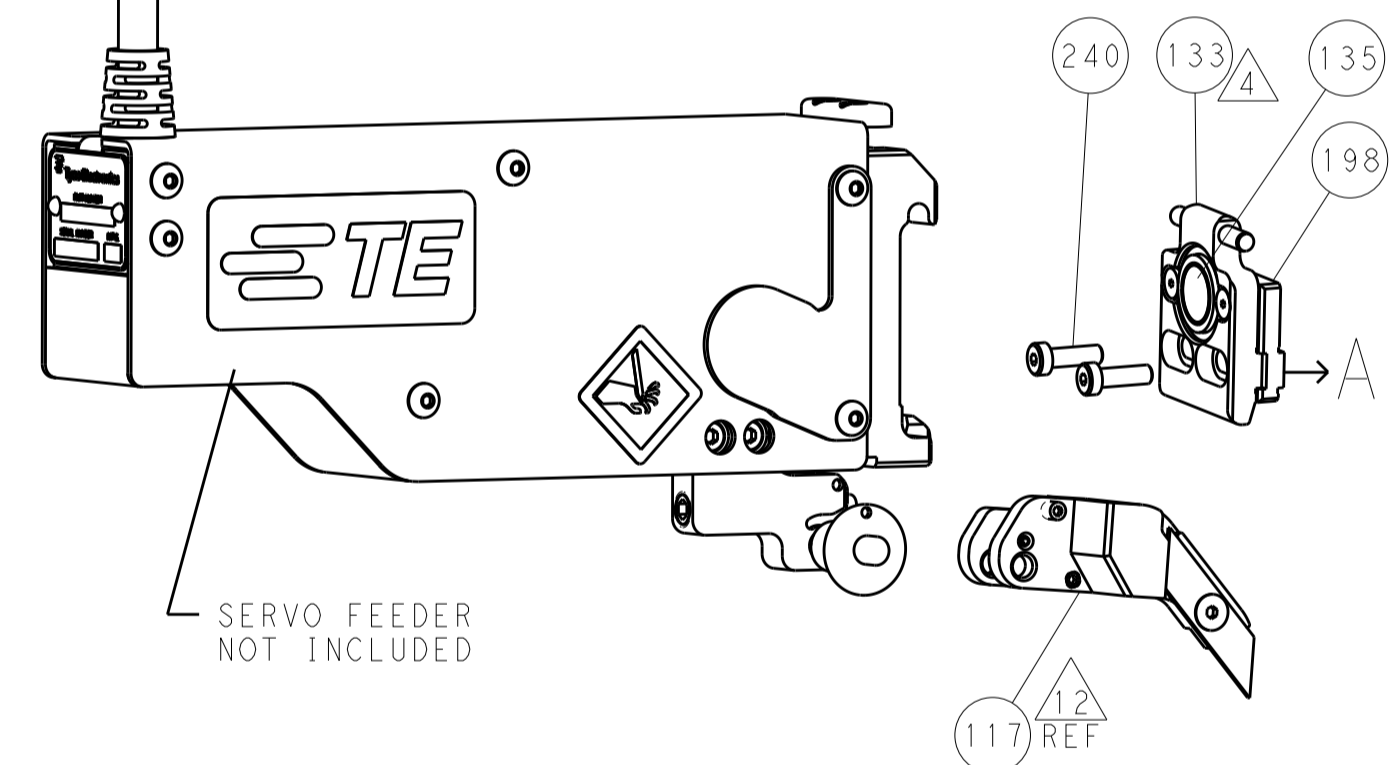

CAM POSITION



AIR FEED

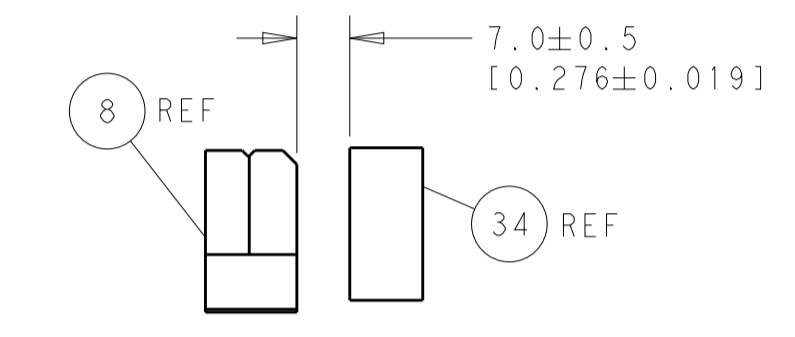
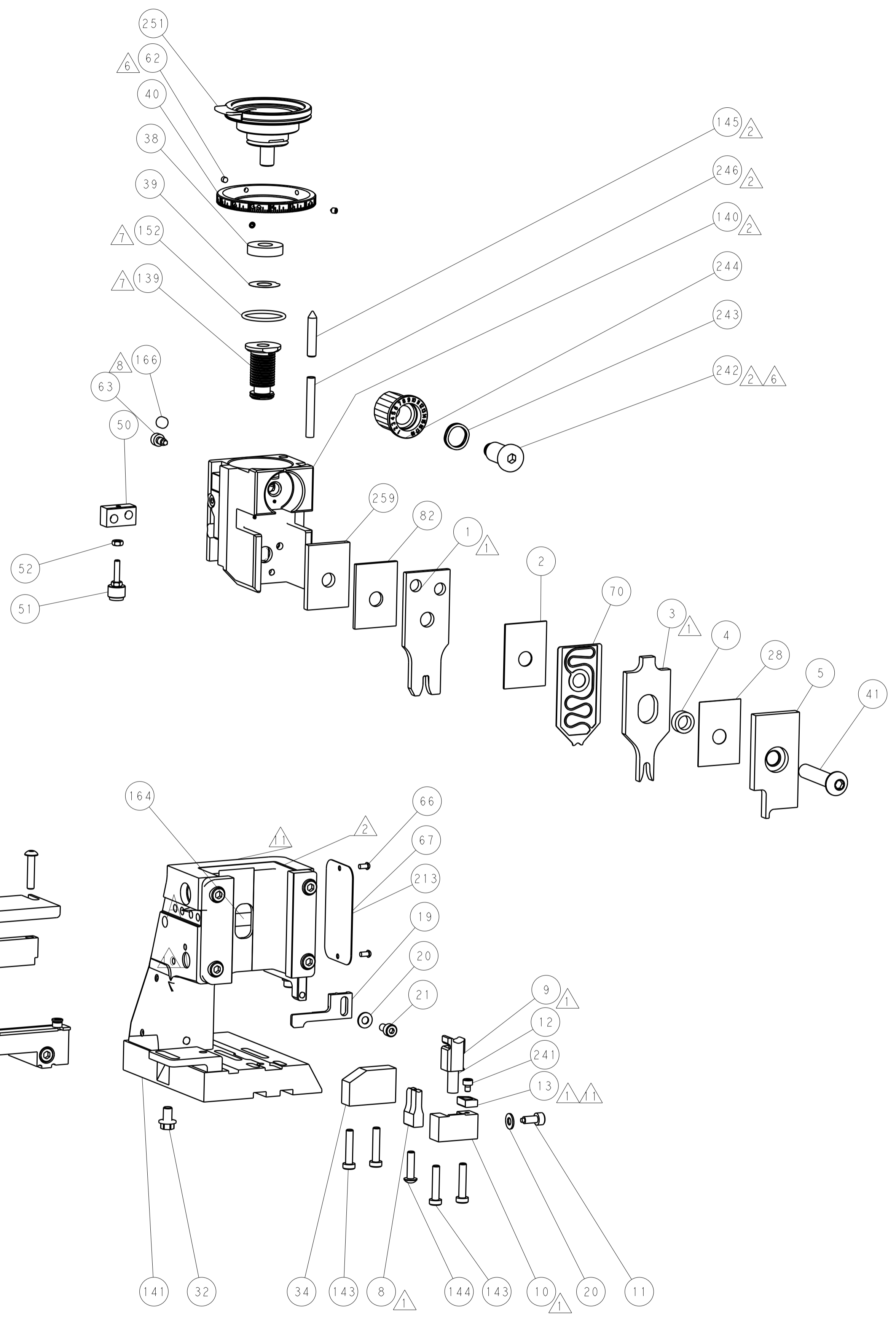

TERMINAL SUPPORT LOCATION

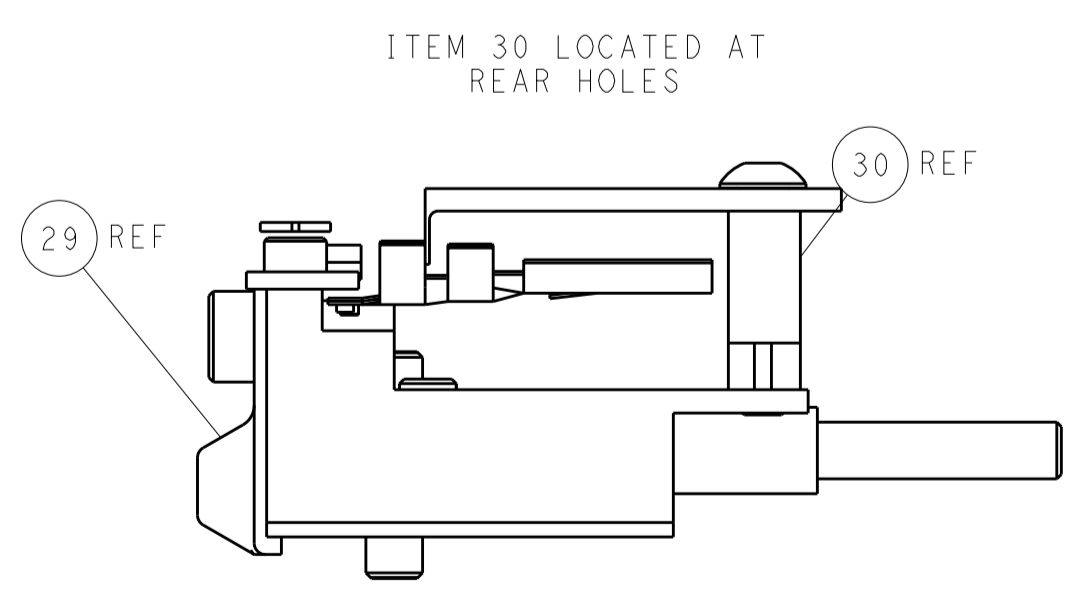

FEED TRACK POSITION
GUIDE BY INSULATION BARREL

PACIFIC VERSION
 Shown on sheets 3 of 4 & 4 of 4
 (Atlantic version shown on sheets 1 of 4 & 2 of 4)

DIMENSIONS:		TOLERANCES UNLESS OTHERWISE SPECIFIED:		DWG Y. YIN 22JUL2014		REVISED BY G. BAILEY 22JUL2014		NAME Ocean Side Feed Applicator	
mm	0 PLC ±0.5	1 PLC ±0.5	2 PLC ±0.13	3 PLC ±0.013	4 PLC ±0.001	ANGLES ±0.001	FINISH	WEIGHT	RESTRICTED TO
MATERIAL								Customer Accessible Production Drawing	SCALE 1:2 SHEET 4 OF 4 REV A1