

THIS DRAWING IS UNPUBLISHED. RELEASED FOR PUBLICATION
 © COPYRIGHT - By - ALL RIGHTS RESERVED.

LOC	DIST	REVISIONS			
P	LTR	DESCRIPTION	DATE	DWN	APVD
D		ECO-14-013776	10NOV14	MGM	CT

DESCRIPTION	MATERIAL	FINISH
MODULE ASSEMBLY	EPOXY THERMOSET	COLOR: BLACK
GROMMET	FLOORSILICONE 40/50 PER MIL-R-25988	COLOR: NATURAL
CONTACT SOCKET	BERYLLIUM COPPER PER ASTM-B194	GOLD PLATE PER MIL-G-45204
RETAINING CLIP	BERYLLIUM COPPER PER ASTM-B194 OR STAINLESS STEEL PER QQ-S-766	NONE

TOP BUSSING ARRANGEMENT

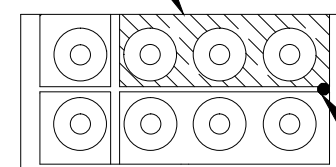

INDEXING INDICATOR

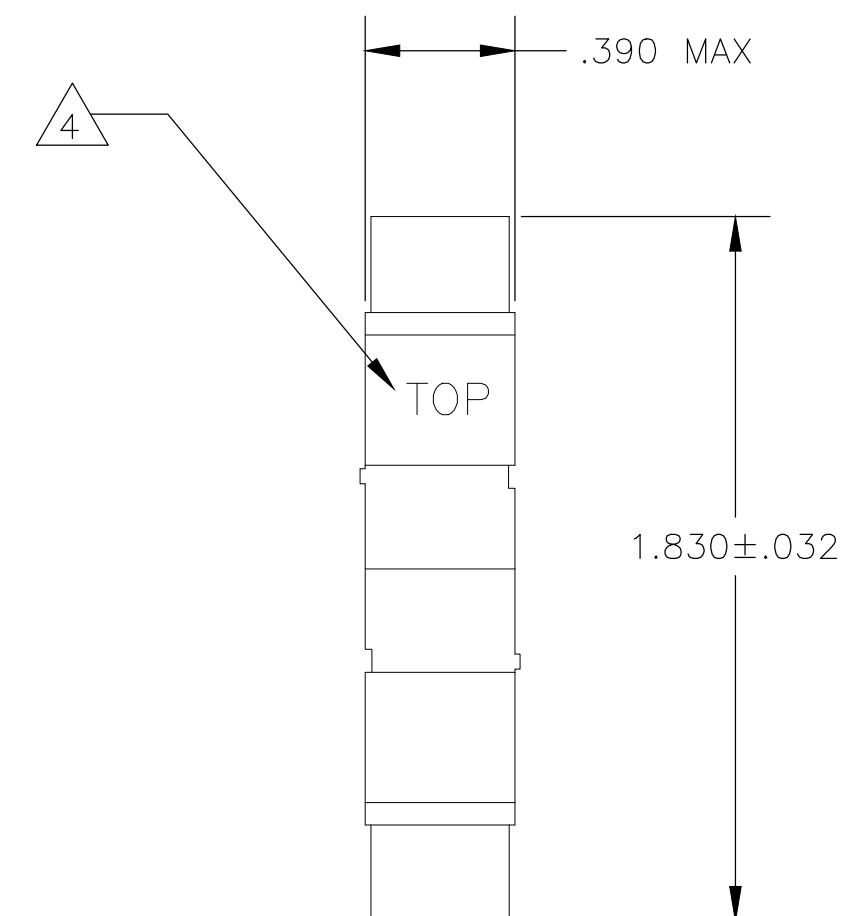
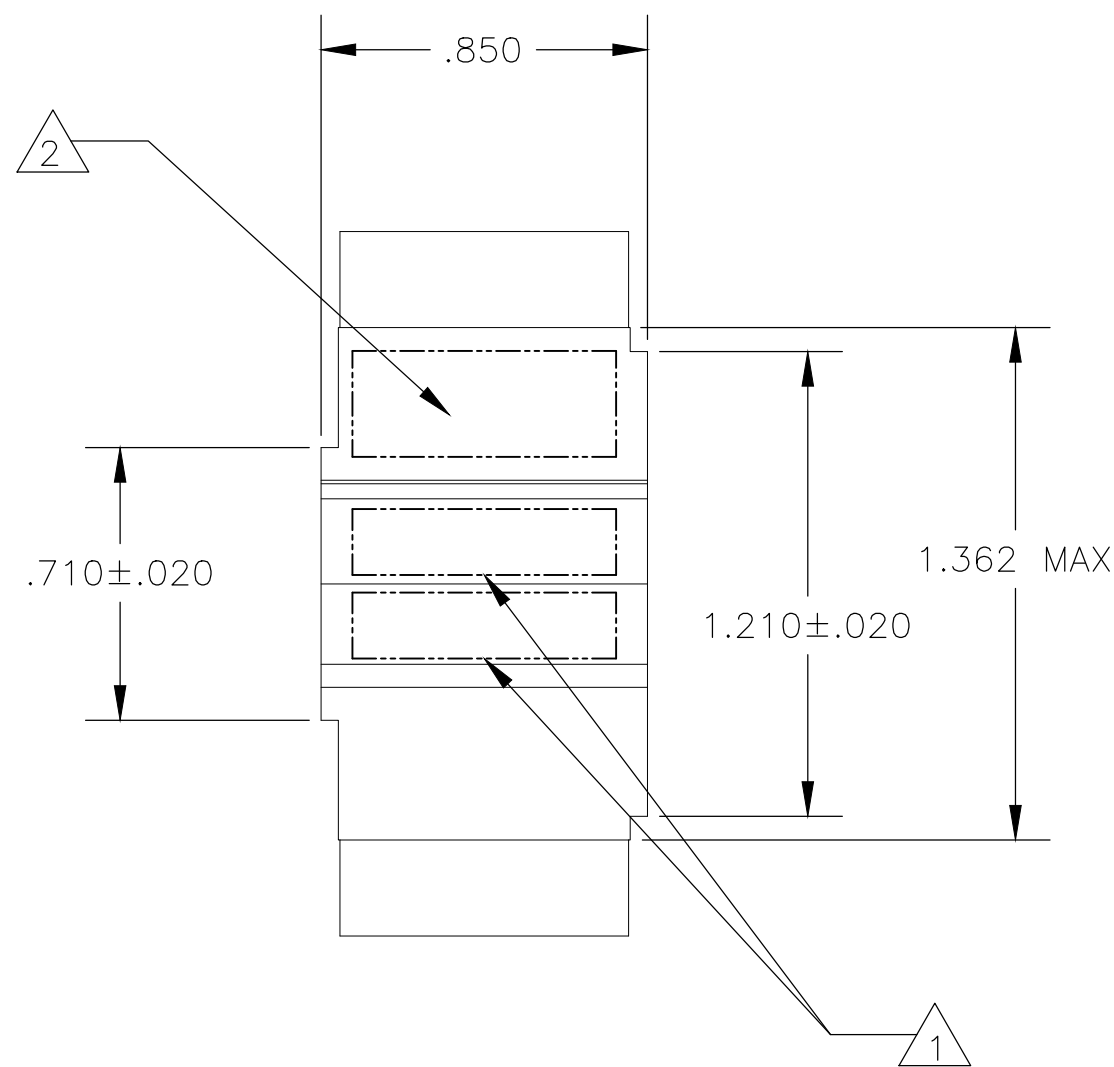

BOTTOM BUSSING ARRANGEMENT

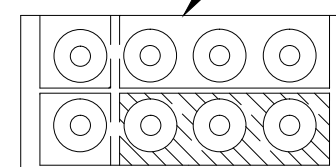

- 1 MARK MODULE ASSEMBLY WITH "AMP", AMP PART NO. AND DATE CODE ON EITHER SIDE.
- 2 MARK MODULE ASSEMBLY WITH CUSTOMER PART NO. 12103B16E15-204 ON EITHER SIDE.
- 3. ROLLS ROYCE QUALITY SPECIFICATION CQC-103 IS INVOKED FOR THIS PART NO.
- 4 MARK WORD "TOP" AT LOCATION SHOWN.

592852

592852-1
PART NO.

THIS DRAWING IS A CONTROLLED DOCUMENT.		DWN N. FRITZ 09-21-93																				
DIMENSIONS: INCHES		CHK R. RYAN 09-21-93																				
TOLERANCES UNLESS OTHERWISE SPECIFIED:		APVD R. RYAN 09-21-93	NAME MODULE, COMBINATION ASSEMBLY SIZE 16 TJ																			
<table border="1"> <tr><td>0 PLC</td><td>±</td><td>-</td></tr> <tr><td>1 PLC</td><td>±</td><td>-</td></tr> <tr><td>2 PLC</td><td>±</td><td>-</td></tr> <tr><td>3 PLC</td><td>±</td><td>.005</td></tr> <tr><td>4 PLC</td><td>±</td><td>-</td></tr> <tr><td>ANGLES</td><td>±</td><td>-</td></tr> </table>		0 PLC	±	-	1 PLC	±	-	2 PLC	±	-	3 PLC	±	.005	4 PLC	±	-	ANGLES	±	-	PRODUCT SPEC -	SIZE A2	CAGE CODE 00779
0 PLC	±	-																				
1 PLC	±	-																				
2 PLC	±	-																				
3 PLC	±	.005																				
4 PLC	±	-																				
ANGLES	±	-																				
MATERIAL	FINISH	WEIGHT -	DRAWING NO C=592852	RESTRICTED TO -																		
CUSTOMER DRAWING			SCALE 2:1	SHEET 1 of 1																		