

THIS DRAWING IS UNPUBLISHED. RELEASED FOR PUBLICATION  
 © COPYRIGHT BY TYCO ELECTRONICS CORPORATION. ALL INTERNATIONAL RIGHTS RESERVED.

LOC	DIST	REVISIONS					
		P	LTR	DESCRIPTION	DATE	DWN	APVD
G	14		B1	REDRAWN PER ECR 10-006147	23MAR10	JR	TM

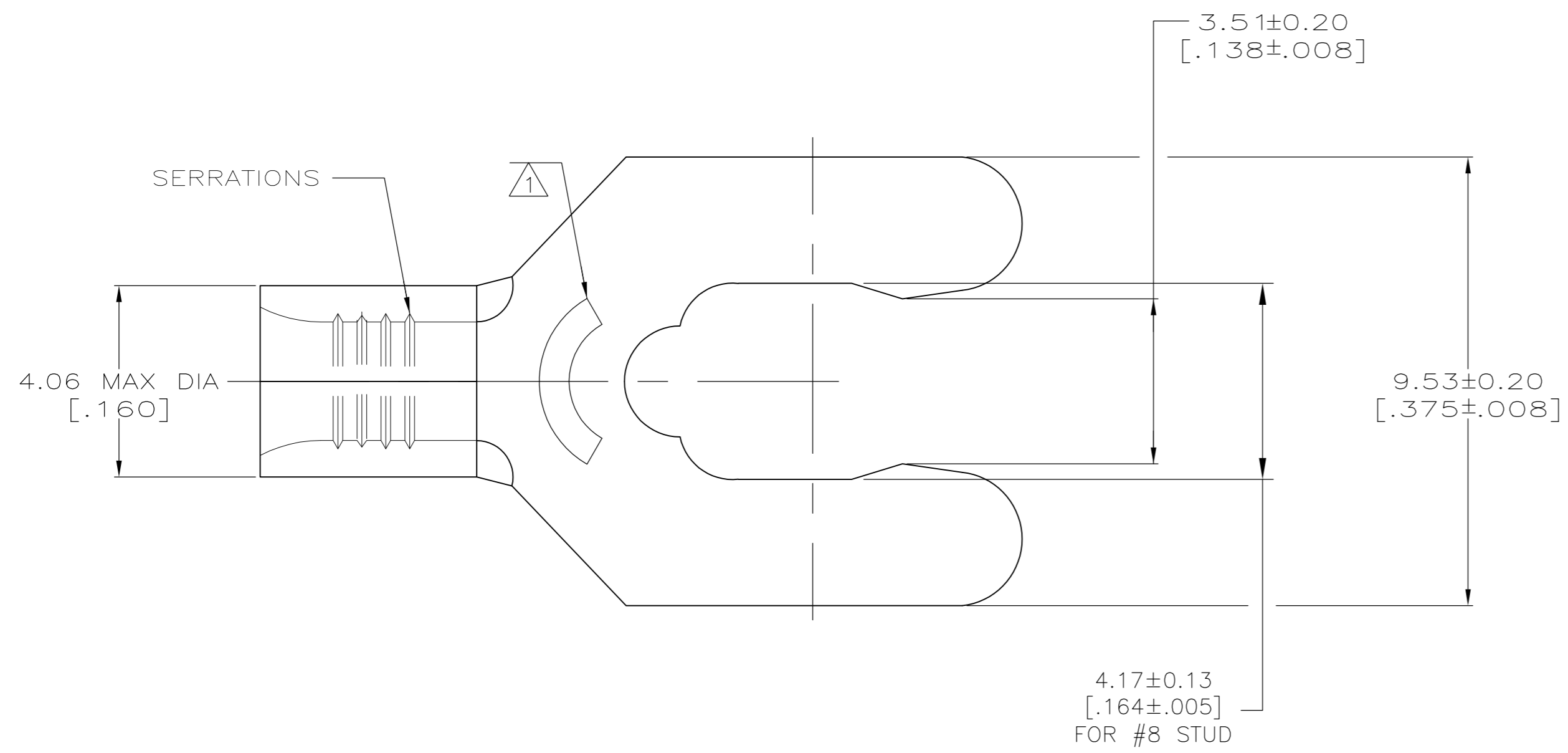

<b>AMP</b> WIRE RANGE	Listed FILE E13288	LR7189 Certified
16-14 AWG STRANDED	16-14 AWG STRANDED	NOT CERTIFIED

- 1 STAMP 8S AMP 16-14\* APPROX AS SHOWN  
8S INDICATES STUD SIZE
- 2 PHOS BRONZE PER ASTM B103, ANNEALED
- 3 TIN PLATE 0.00254 [.000100] MIN THK PER  
ASTM B545

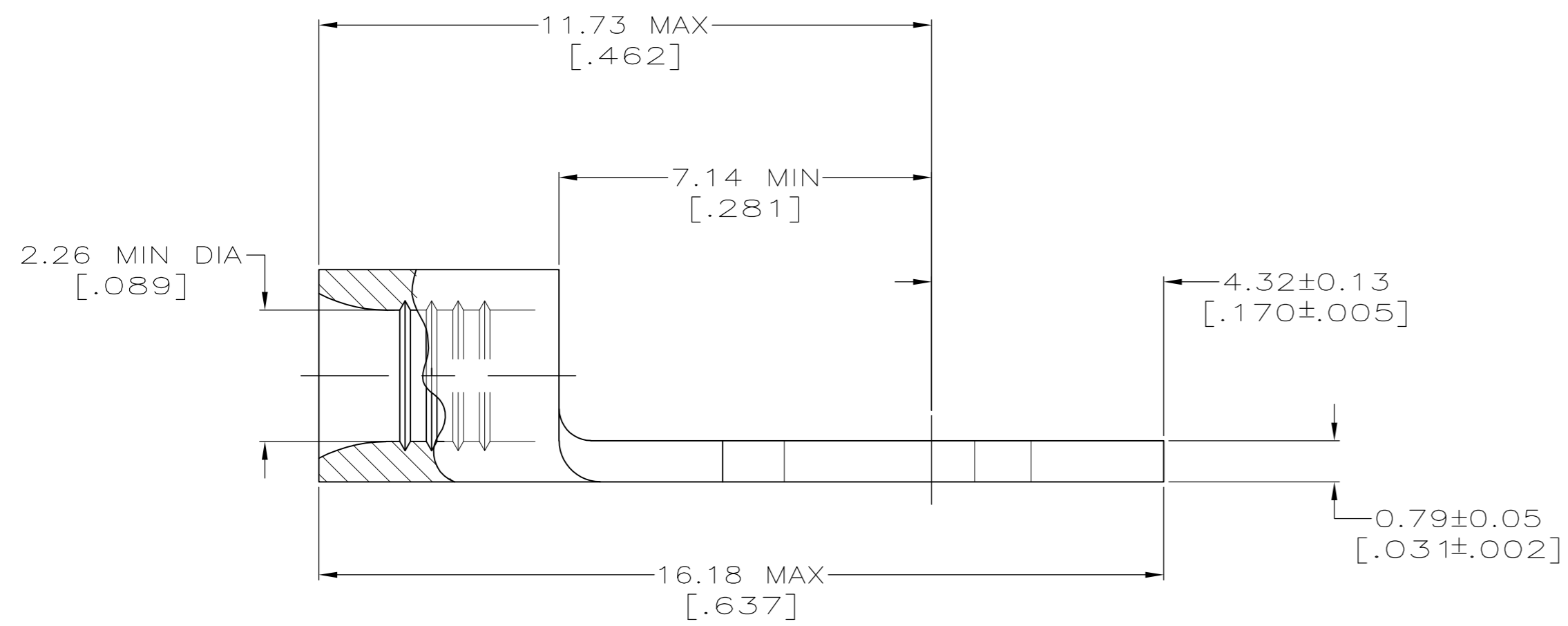

53011-1  
PART NO.

<b>CUSTOMER SERVICE SYSTEMS</b>		MAX RECOMMENDED OPERATING TEMPERATURE: 170°C MAX		THIS DRAWING IS A CONTROLLED DOCUMENT.		DWN TA BRINKMAN 2-12-93		Tyco Electronics Corporation Harrisburg, PA 17105-3608			
FOR ADDITIONAL PRODUCT INFORMATION OR COPIES OF DRAWINGS AND TECHNICAL DOCUMENTS	PRODUCT INFORMATION CENTER 1-800-522-6752	VOLTAGE RATING: N/A		DIMENSIONS: MM [ INCHES ]	TOLERANCES UNLESS OTHERWISE SPECIFIED:	CHK DA PATTERSON 2-12-93	APVD JL MECKLEY 2-12-93	NAME TERMINAL, SHORT SPRING SPADE, BUDGET 16-14			
FOR APPLICATION TOOLING INFORMATION	TOOLING ASSISTANCE CENTER 1-800-722-1111	CIRCULAR MIL AREA: 1.04-2.62mm² [2,050-5,180] STRANDED			0 PLC ± - 1 PLC ± - 2 PLC ± - 3 PLC ± - 4 PLC ± - ANGLES ± -	PRODUCT SPEC	APPLICATION SPEC	SIZE	CAGE CODE	DRAWING NO	RESTRICTED TO
FOR ORDER ENTRY	1-800-526-5142	THIS DRAWING IS A CONTROLLED DOCUMENT FOR AMP INCORPORATED. IT IS SUBJECT TO CHANGE AND THE CONTROLLING ENGINEERING ORGANIZATION SHOULD BE CONTACTED FOR THE LATEST REVISION.		MATERIAL	FINISH	WEIGHT	SCALE	SHEET	1 OF 1	REV	B1

53011