

how to hand crimp



NOTE: This hand tool is primarily intended for standard conductor sizes. It may not give a good insulation crimp support for all wire variations.

CAUTION: This tool is adjustable. See illustration 6 before use, set jaw eccentric to maximum opening then adjust crimp to wire pull test. Failure to follow this procedure can result in tool breakage.

Follow these six simple steps to fast, *positive* terminal crimping.

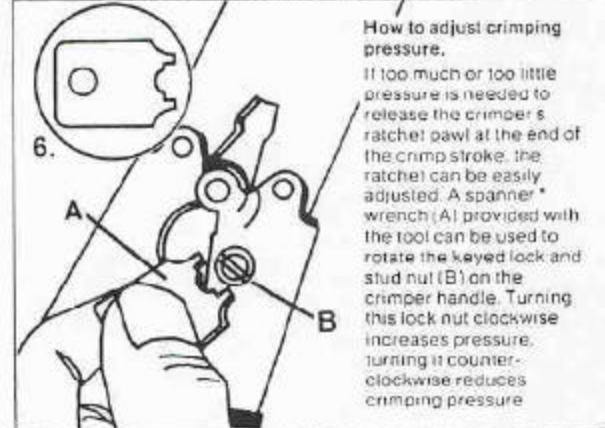
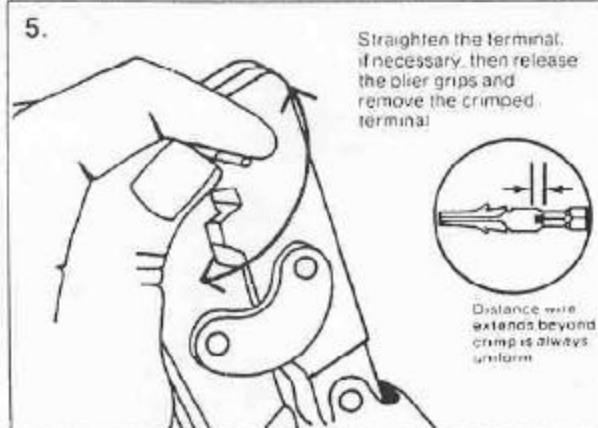
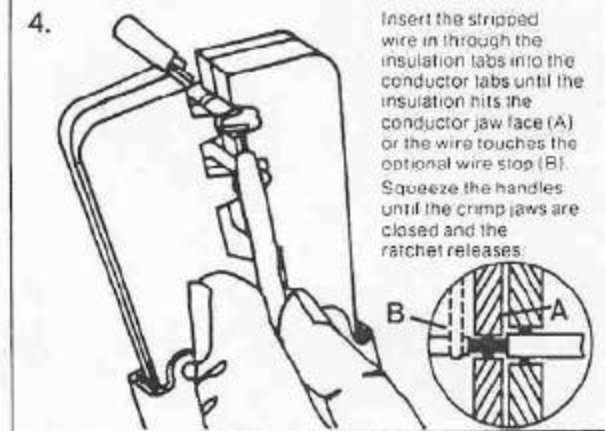
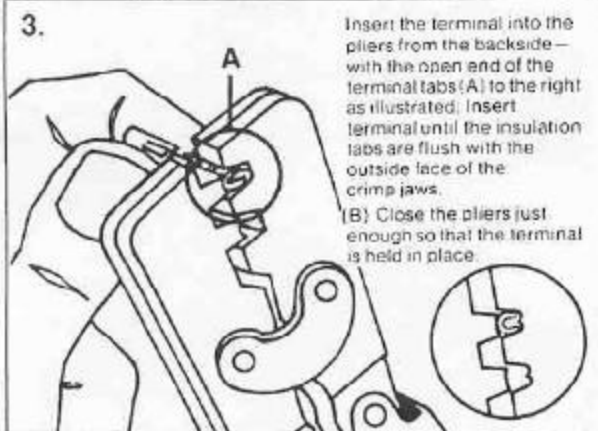
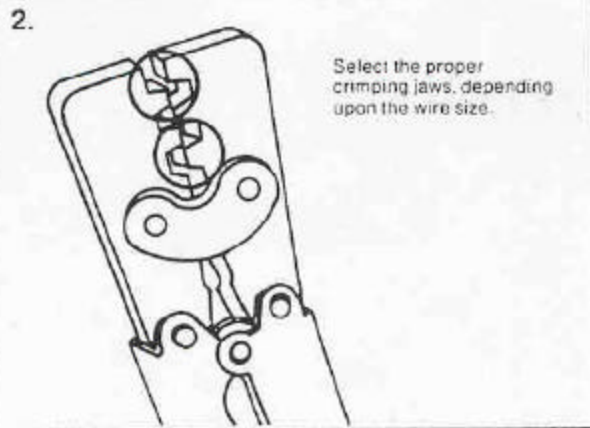
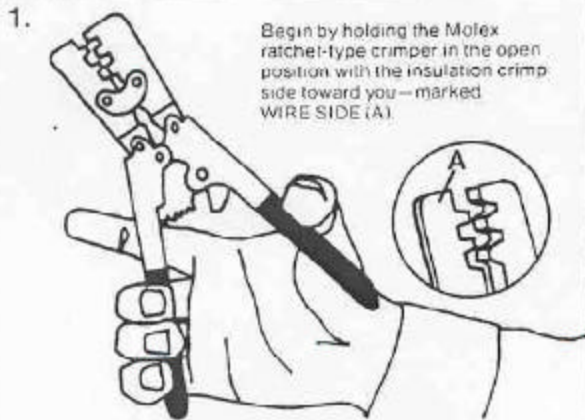

For additional copies of this instruction sheet, write to Molex Incorporated, 2222 Wellington Ct., Lisle, Illinois 60532

*Newer models should be adjusted with a screw driver.

**REPLACEMENT PARTS
FOR NO. 4160
HANDLE ASSEMBLY**

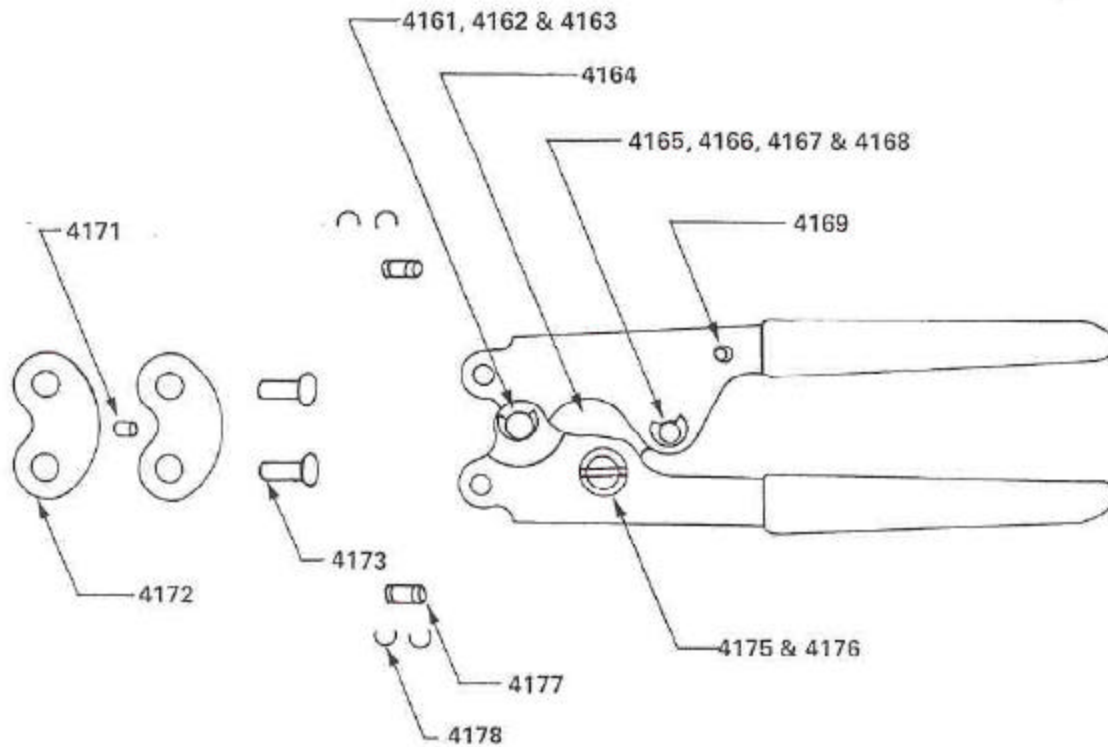

ORDER NO.	ENGINEERING NO.	DESCRIPTION
11-11-0008	4160	Handle Assembly
11-11-0011	4161	Pivot Pin
11-11-0012	4162	Retaining Ring (2 Req'd.)
11-11-0003	4163	Torsion Spring
11-11-0013	4164	Ratchet
11-11-0014	4165	Pawl
11-11-0015	4166	Pawl Pivot Pin
11-11-0016	4167	Retaining Ring (2 Req'd.)
11-11-0017	4168	Pawl Spring
11-11-0018	4169	Spring Retaining Pin
11-11-0019	4170	Inside Handle
11-11-0020	4171	Insert Pivot Pin
11-11-0021	4172	Link (2 Req'd.)
11-11-0022	4173	Rivet (2 Req'd.)
11-11-0023	4174	Outside Handle
11-11-0024	4175	Eccentric Stud
11-11-0025	4176	Nut
11-11-0026	4177	Handle Pin (2 Req'd.)
11-11-0027	4178	Retaining Ring (4 Req'd.)
11-11-0001	4179	Adjustment Wrench

HAND TOOL PULL TEST STANDARDS						
		PULL REQUIRED BY MATERIAL THICKNESS				
A.W.G.	(XX MM) ²	.015 Lbs (Kg)	.013 Lbs (Kg)	.010 Lbs (Kg)	.008 Lbs (Kg)	.006 Lbs (Kg)
10	{ 5,25 MM} ²	80 (36,29)	80 (36,29)			
12	{ 3,25 MM} ²	70 (31,75)	70 (31,75)			
14	{ 2,00 MM} ²	58 (26,31)	60 (27,24)	40 (18,14)		
16	{ 1,30 MM} ²	45 (20,41)	50 (22,70)	35 (15,88)		
18	{ 0,80 MM} ²	35 (15,88)	35 (15,88)	25 (11,34)	25 (11,34)	20 (9,07)
20	{ 0,50 MM} ²	18 (8,16)	25 (11,35)	15 (6,80)	14 (6,35)	14 (6,35)
22	{ 0,35 MM} ²			12 (5,44)	10 (5,44)	10 (5,44)
24	{ 0,20 MM} ²			8 (3,62)	8 (3,62)	8 (3,62)
26	{ 0,12 MM} ²			6 (2,72)	6 (2,72)	6 (2,72)
28	{ 0,07 MM} ²			4 (1,81)	4 (1,81)	4 (1,81)
30	{ 0,05 MM} ²			3 (1,36)	3 (1,36)	3 (1,36)

HAND CRIMPING TOOL

DAILY MAINTENANCE AND INSPECTION PROCEDURE

1. Clean all dust, dirt, moisture and other foreign matter from the crimp jaws and linkage with a soft brush or lint free cloth. Do not use tools or objects that could damage the crimp area of the jaws.
2. The pivot pin and bearing surfaces should have a light coat of oil to insure smooth operation.
3. Crimp terminal sample, then check the pull test results against the Molex specifications above.
4. If the crimped terminal fails to meet the Molex specification, make adjustments in pressure following illustration #6 on "How To Hand Crimp".
5. When storing the tool, close the handles till the pawl is about to be released from the last tooth of the ratchet. This will hold the crimp jaws closed to prevent any objects from lodging within the crimp area.

PERIODIC INSPECTION SCHEDULE & PROCEDURE

Schedule:

Regular periodic visual inspections should be performed on the tool based on the amount of use, working conditions, operator skill and care. One such inspection a month would be recommended for a tool used regularly.

Procedure:

1. Partially close the tool and immerse it up to the plastic handle covers into a commercial solvent that will not affect paint or plastic.
2. Dry with air blast or by wiping with a lint free cloth and shaking the excess solvent from the tool.
3. Close the handles till the pawl is released from the ratchet. Release one handle. If it does not open quickly and freely, the torsion spring is worn and should be replaced.
4. Check the tension of the pawl spring and replace if necessary.
5. Inspect all crimp areas for any chipped, flattened, cracked, worn or broken crimp surfaces. If crimp area is damaged, return the tool to Molex for evaluation and repair.
6. Before the tool is put into service, crimp a sample terminal on a wire and compare the pull test with Pull Test Standards above.
7. If adjustments in crimp pressure are required, follow instructions shown in illustration #6, "How To Hand Crimp".



Hand Crimp Tool

Hand Tool Identification

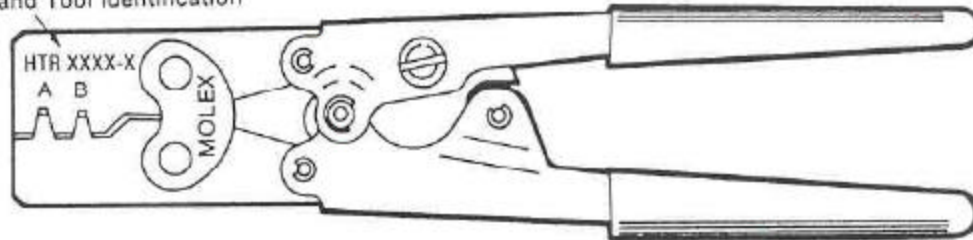

Terminal	Strip Length IN. (MM)	Wire Range AWG (XX) MM ²	Insul. Dia. Max. IN. (MM)	Hand Tool Eng. No.	Hand Tool Order No.	Crimp A	Position B
*1189	.156/.218 (3.96/5.53)	14-20 (2.00/0.50mm) ²	.140 (3.55)	HTR-1031-E	11-01-0084	—	14-20
*1190	.156/.218 (3.96/5.53)	14-20 (2.00/0.50mm) ²	.140 (3.55)	HTR-1031-E	11-01-0084	—	14-20
1219	.171/.203 (4.34/5.15)	12-14 (3.25/2.00mm) ²	.165 (4.19)	HTR-4067	11-01-0040	12-14	—
1220	.171/.203 (4.34/5.15)	12-14 (3.25/2.00mm) ²	.165 (4.19)	HTR-4067	11-01-0040	12-14	—
*1380	.156/.218 (3.96/5.53)	18-22 (0.80/0.35mm) ²	.120 (3.04)	HTR-1031-E	11-01-0084	20-22	18
*1381	.156/.218 (3.96/5.53)	18-22 (0.80/0.35mm) ²	.120 (3.04)	HTR-1031-E	11-01-0084	20-22	18
1433	.156/.218 (3.96/5.53)	24-30 (0.35/0.05mm) ²	.060 (1.52)	HTR-2262	11-01-0006	24-30	—
1434	.156/.218 (3.96/5.53)	24-30 (0.35/0.05mm) ²	.060 (1.52)	HTR-2262	11-01-0006	24-30	—
1450	.156/.218 (3.96/5.53)	14-20 (2.00/0.50mm) ²	.140 (3.55)	HTR-1031-E	11-01-0084	—	14-20
1451	.156/.218 (3.96/5.53)	14-20 (2.00/0.50mm) ²	.140 (3.55)	HTR-1031-E	11-01-0084	—	14-20
1457-1	.156/.218 (3.96/5.53)	16-22 (1.30/0.35mm) ²	.135 (3.42)	HTR-1031-E	11-01-0084	20-22	16-18
1457-2	.156/.218 (3.96/5.53)	14-16 (2.00/1.30mm) ²	.140 (3.55)	HTR-1031-E	11-01-0084	—	14-16
1508-1	.156/.218 (3.96/5.53)	14-20 (2.00/0.50mm) ²	.140 (3.55)	HTR-2450	11-01-0023	14-20	—
*1560	.125/.156 (3.17/3.96)	18-24 (0.80/0.20mm) ²	.110 (2.79)	HTR-1719-C	11-01-0008	20-24	18
*1561	.125/.156 (3.17/3.96)	18-24 (0.80/0.20mm) ²	.110 (2.79)	HTR-1719-C	11-01-0008	20-24	18
*1589	.156/.218 (3.96/5.53)	18-22 (0.80/0.12mm) ²	.120 (3.04)	HTR-1031-E	11-01-0084	20-22	18
*1590	.156/.218 (3.96/5.53)	18-22 (0.80/0.12mm) ²	.120 (3.04)	HTR-1031-E	11-01-0084	20-22	18
*1786	.125/.156 (3.17/3.96)	18-24 (0.80/0.20mm) ²	.110 (2.79)	HTR-1719-C	11-01-0008	20-24	18
*1787	.125/.156 (3.17/3.96)	18-24 (0.80/0.20mm) ²	.110 (2.79)	HTR-1719-C	11-01-0008	20-24	18
*1793	.125/.156 (3.17/3.96)	18-24 (0.80/0.20mm) ²	.110 (2.79)	HTR-1719-C	11-01-0008	20-24	18



Hand Crimp Tool

Hand Tool Identification

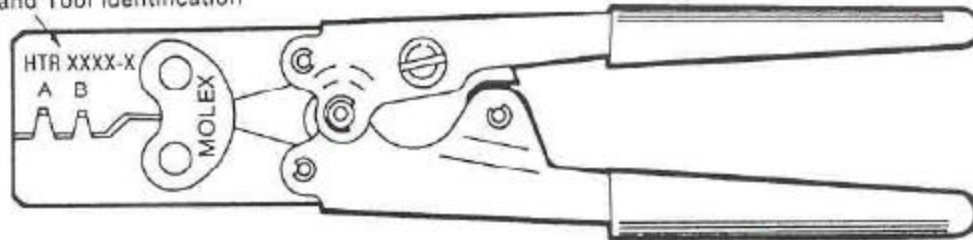

Terminal	Strip Length IN. (MM)	Wire Range AWG (XX) MM ²	Insul. Dia. Max. IN. (MM)	Hand Tool Eng. No.	Hand Tool Order No.	Crimp A	Position B
*1189	.156/.218 (3.96/5.53)	14-20 (2.00/0.50mm) ²	.140 (3.55)	HTR-1031-E	11-01-0084	—	14-20
*1190	.156/.218 (3.96/5.53)	14-20 (2.00/0.50mm) ²	.140 (3.55)	HTR-1031-E	11-01-0084	—	14-20
1219	.171/.203 (4.34/5.15)	12-14 (3.25/2.00mm) ²	.165 (4.19)	HTR-4067	11-01-0040	12-14	—
1220	.171/.203 (4.34/5.15)	12-14 (3.25/2.00mm) ²	.165 (4.19)	HTR-4067	11-01-0040	12-14	—
*1380	.156/.218 (3.96/5.53)	18-22 (0.80/0.35mm) ²	.120 (3.04)	HTR-1031-E	11-01-0084	20-22	18
*1381	.156/.218 (3.96/5.53)	18-22 (0.80/0.35mm) ²	.120 (3.04)	HTR-1031-E	11-01-0084	20-22	18
1433	.156/.218 (3.96/5.53)	24-30 (0.35/0.05mm) ²	.060 (1.52)	HTR-2262	11-01-0006	24-30	—
1434	.156/.218 (3.96/5.53)	24-30 (0.35/0.05mm) ²	.060 (1.52)	HTR-2262	11-01-0006	24-30	—
1450	.156/.218 (3.96/5.53)	14-20 (2.00/0.50mm) ²	.140 (3.55)	HTR-1031-E	11-01-0084	—	14-20
1451	.156/.218 (3.96/5.53)	14-20 (2.00/0.50mm) ²	.140 (3.55)	HTR-1031-E	11-01-0084	—	14-20
1457-1	.156/.218 (3.96/5.53)	16-22 (1.30/0.35mm) ²	.135 (3.42)	HTR-1031-E	11-01-0084	20-22	16-18
1457-2	.156/.218 (3.96/5.53)	14-16 (2.00/1.30mm) ²	.140 (3.55)	HTR-1031-E	11-01-0084	—	14-16
1508-1	.156/.218 (3.96/5.53)	14-20 (2.00/0.50mm) ²	.140 (3.55)	HTR-2450	11-01-0023	14-20	—
*1560	.125/.156 (3.17/3.96)	18-24 (0.80/0.20mm) ²	.110 (2.79)	HTR-1719-C	11-01-0008	20-24	18
*1561	.125/.156 (3.17/3.96)	18-24 (0.80/0.20mm) ²	.110 (2.79)	HTR-1719-C	11-01-0008	20-24	18
*1589	.156/.218 (3.96/5.53)	18-22 (0.80/0.12mm) ²	.120 (3.04)	HTR-1031-E	11-01-0084	20-22	18
*1590	.156/.218 (3.96/5.53)	18-22 (0.80/0.12mm) ²	.120 (3.04)	HTR-1031-E	11-01-0084	20-22	18
*1786	.125/.156 (3.17/3.96)	18-24 (0.80/0.20mm) ²	.110 (2.79)	HTR-1719-C	11-01-0008	20-24	18
*1787	.125/.156 (3.17/3.96)	18-24 (0.80/0.20mm) ²	.110 (2.79)	HTR-1719-C	11-01-0008	20-24	18
*1793	.125/.156 (3.17/3.96)	18-24 (0.80/0.20mm) ²	.110 (2.79)	HTR-1719-C	11-01-0008	20-24	18



Hand Crimp Tool

Hand Tool Identification

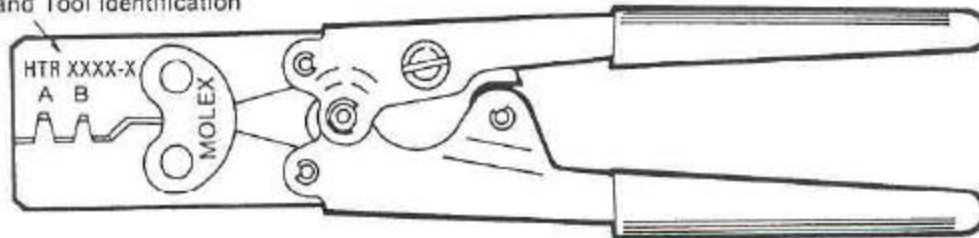

Terminal	Strip Length IN. (MM)	Wire Range AWG (XX) MM ²	Insul. Dia. Max. IN. (MM)	Hand Tool Eng. No.	Hand Tool Order No.	Crimp A	Position B
2176	.140/.187 (3.55/4.74)	14-22 (2.00/0.35mm) ²	.140 (3.55)	HTR-2450-A	11-01-0101	18-22	(1) 14-18 (2)
2189	.125/.156 (3.17/3.96)	24-30 (0.20/0.05mm) ²	.070 (1.77)	HTR-2262-A	11-01-0037	24-30	—
2190	.125/.156 (3.17/3.96)	24-30 (0.20/0.05mm) ²	.070 (1.77)	HTR-2262-A	11-01-0037	24-30	—
2192	.156/.218 (3.96/5.53)	24-30 (0.20/0.05mm) ²	.060 (1.52)	HTR-2262	11-01-0006	24-30	—
*2236	.156/.218 (3.96/5.53)	20-22 (0.50/0.35mm) ²	.060 (1.52)	HTR-1031-E	11-01-0084	20-22	—
*2237	.156/.218 (3.96/5.53)	20-22 (0.50/0.35mm) ²	.060 (1.52)	HTR-1031-E	11-01-0084	20-22	—
*2269	.156/.218 (3.96/5.53)	14-20 (2.00/0.50mm) ²	.140 (3.55)	HTR-1031-E	11-01-0084	—	14-20
*2273	.156/.218 (3.96/5.53)	18-22 (0.80/0.35mm) ²	.120 (3.04)	HTR-1031-E	11-01-0084	20-22	18
*2282	.156/.218 (3.96/5.53)	14-18 (2.00/0.80mm) ²	.140 (3.55)	HTR-1031-E	11-01-0084	—	14-18
*2283	.156/.218 (3.96/5.53)	14-18 (2.00/0.80mm) ²	.140 (3.55)	HTR-1031-E	11-01-0084	—	14-18
2328	.140/.187 (3.55/4.74)	14-22 (2.00/0.35mm) ²	.140 (3.55)	HTR-2450	11-01-0023	18-22	14-18
*2477	.100/.125 (2.54/3.17)	18-24 (0.80/0.20mm) ²	.110 (2.79)	HTR-2445-A	11-01-0026	18-24	—
*2478	.100/.125 (2.54/3.17)	18-24 (0.80/0.20mm) ²	.110 (2.79)	HTR-2445-A	11-01-0026	18-24	—
2482	.167/.218 (4.74/5.53)	12-14 (3.25/2.00mm) ²	.165 (4.19)	HTR-2843	11-01-0044	12-14	—
2576	.140/.187 (3.55/4.74)	14-22 (2.00/0.35mm) ²	.140 (3.55)	HTR-2450-A	11-01-0101	18-22	(1) 14-18 (2)
*2578	.100/.125 (2.54/3.17)	22-26 (0.35/0.12mm) ²	.060 (1.52)	HTR-2445-A	11-01-0026	—	22-26
*2679	.125/.156 (3.17/3.96)	18-24 (0.80/0.20mm) ²	.110 (2.79)	HTR-1719-C	11-01-0008	20-24	18
2697-1	.156/.218 (3.96/5.53)	12-20 (3.25/0.50mm) ²	.188 (4.77)	HTR-1758	11-01-0011	12-20	—
2697-2	.156/.218 (3.96/5.53)	12-20 (3.25/0.50mm) ²	.230 (5.84)	HTR-2266	11-01-1020	12-20	—
2698	.156/.218 (3.96/5.53)	14-22 (2.00/0.35mm) ²	.140 (3.55)	HTR-2450	11-01-0023	18-22	14-18
2699	.156/.218 (3.96/5.53)	12-20 (3.25/0.50mm) ²	.188 (4.77)	HTR-1758	11-01-0011	12-20	—



Hand Crimp Tool

Hand Tool Identification

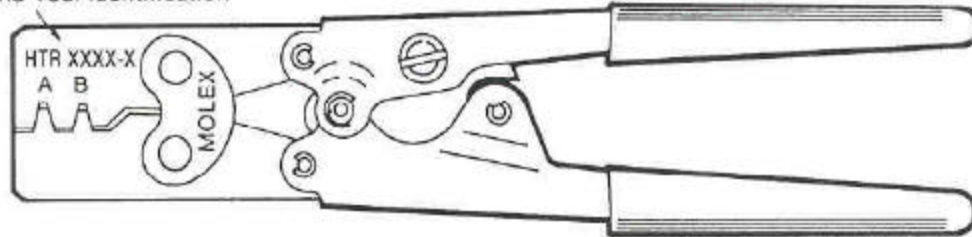

Terminal	Strip Length IN. (MM)	Wire Range AWG (XX) MM ²	Insul. Dia. Max. IN. (MM)	Hand Tool Eng. No.	Hand Tool Order No.	Crimp A	Position B
2717	.125/.156 (3.17/3.96)	24-30 (0.20/0.05mm) ²	.070 (1.77)	HTR-2262-A	11-01-0037	24-30	—
2759	.100/.125 (2.54/3.17)	24-30 (0.20/0.05mm) ²	.062 (1.57)	HTR-2262-A	11-01-0037	24-30	—
2776	.156/.218 (3.96/5.53)	14-20 (2.00/0.50mm) ²	.140 (3.55)	HTR-2090-A	11-01-0019	14-20	—
2799	.156/.218 (3.96/5.53)	24-28 (0.20/0.07mm) ²	.070 (1.77)	HTR-2262	11-01-0006	24-28	—
2855	.125/.156 (3.17/3.96)	18-24 (0.80/0.20mm) ²	.110 (2.79)	HTR-1719-C	11-01-0008	20-24	18
2870	.156/.218 (3.96/5.53)	22-24 (0.35/0.20mm) ²	.070 (1.77)	HTR-7176	11-01-0097	22-24	—
2871	.156/.218 (3.96/5.53)	22-24 (0.35/0.20mm) ²	.070 (1.77)	HTR-7176	11-01-0097	22-24	—
2878	.125/.156 (3.17/3.96)	18-24 (0.80/0.20mm) ²	.110 (2.79)	HTR-2445-A	11-01-0026	18-24	—
2951	.125/.156 (3.17/3.96)	24-30 (0.20/0.05mm) ²	.070 (1.77)	HTR-2262-A	11-01-0037	24-30	—
3100	.125/.158 (3.17/3.96)	24-30 (0.20/0.05mm) ²	.070 (1.77)	HTR-2262	11-01-0006	24-30	—
4018	.100/.125 (2.54/3.17)	18-24 (0.80/0.20mm) ²	.110 (2.79)	HTR-2445-A	11-01-0026	18-24	—
4259	.100/.125 (2.54/3.17)	24-30 (0.20/0.05mm) ²	.070 (1.77)	HTR-7051	11-01-0072	24-30	—
4268	.156/.218 (3.96/5.53)	14-20 (2.00/0.50mm) ²	.140 (3.55)	HTR-1031-E	11-01-0084	—	14-20
4272	.156/.218 (3.96/5.53)	18-22 (0.80/0.35mm) ²	.120 (3.04)	HTR-1031-E	11-01-0084	20-22	14-18
4292	.156/.218 (3.96/5.53)	24-30 (0.20/0.05mm) ²	.060 (1.52)	HTR-2262	11-01-0006	24-30	—
4295	.125/.156 (3.17/3.96)	18-24 (0.80/0.20mm) ²	.110 (2.79)	HTR-1719-C	11-01-0008	20-24	18
4296	.156/.218 (3.96/5.53)	16-22 (1.30/0.35mm) ²	.120 (3.04)	HTR-1031-E	11-01-0084	20-22	16-18
4296-1	.156/.218 (3.96/5.53)	16-22 (1.30/0.35mm) ²	.120 (3.04)	HTR-1031-E	11-01-0084	20-22	16-18
4366	.125/.156 (3.17/3.96)	18-24 (0.80/0.20mm) ²	.110 (2.79)	HTR-6115	11-01-0058	18-24	—
4428-1	.125/.156 (3.17/3.96)	18-24 (0.80/0.20mm) ²	.110 (2.79)	HTR-2445-A	11-01-0026	18-24	—
4428-3	.125/.156 (3.17/3.96)	22-26 (0.35/0.12mm) ²	.062 (1.57)	HTR-2445-A	11-01-0026	—	22-26



Hand Crimp Tool

Hand Tool Identification

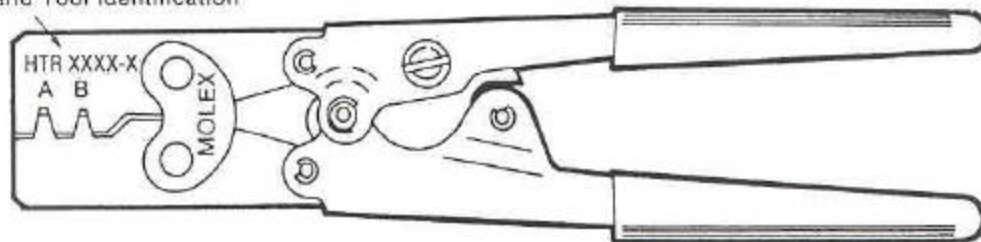

Terminal	Strip Length IN. (MM)	Wire Range AWG (XX) MM ²	Insul. Dia. Max. IN. (MM)	Hand Tool Eng. No.	Hand Tool Order No.	Crimp A	Position B
4428-7	.125/.156 (3,17/3,96)	18-24 (0,80/0,20mm) ²	—	HTR-2445-A	11-01-0026	18-24	—
4499	.125/.187 (3,17/4,74)	18-24 (0,80/0,20mm) ²	.125 (3,05)	HTR-1719-C	11-01-0008	20-24	18
4529	.125/.156 (3,17/3,96)	18-24 (0,80/0,20mm) ²	.110 (2,79)	HTR-1719-C	11-01-0008	20-24	18
4548	.100/.125 (2,54/3,17)	24-30 (0,20/0,05mm) ²	.062 (1,57)	HTR-2262-A	11-01-0037	24-30	—
4549	.156/.218 (3,96/5,53)	14-20 (2,00/0,50mm) ²	.140 (3,55)	HTR-1031-E	11-01-0084	—	14-20
*4550	.156/.218 (3,96/5,53)	14-20 (2,00/0,50mm) ²	.140 (3,55)	HTR-1031-E	11-01-0084	—	14-20
4559	.125/.156 (3,17/3,96)	24-30 (0,20/0,05mm) ²	.070 (1,77)	HTR-2262-A	11-01-0037	24-30	—
4563	.156/.218 (3,96/5,53)	18-26 (0,80/0,12mm) ²	.120 (3,04)	HTR-1031-E	11-01-0084	20-22	18
4573	.125/.156 (3,17/3,96)	24-30 (0,20/0,05mm) ²	.070 (1,77)	HTR-6115	11-01-0058	—	24-30
*4578	.100/.125 (2,54/3,17)	18-24 (0,80/0,20mm) ²	.110 (2,79)	HTR-2445-A	11-01-0026	18-24	—
4583	.125/.156 (3,17/3,96)	22-30 (0,35/0,05mm) ²	.060 (1,52)	HTR-2445-A	11-01-0026	—	24-30
4706	.234/.250 (5,94/6,35)	18-22 Std. Cr. (0,80/0,35mm) ²	.118 (2,99)	HTR-4971-A	11-01-0065	18-22	—
4706-1	.234/.250 (5,94/6,35)	18 Std. Cr. (0,80mm) ²	.118 (2,99)	HTR-4971-B	11-01-0066	18	—
4706-2	.234/.250 (5,94/6,35)	18-22 Std. Cr. (0,80/0,35mm) ²	.118 (2,99)	HTR-4971-C	11-01-0067	18-22	—
4706-3	.234/.250 (5,94/6,35)	18-22 Std. Cr. (0,80/0,35mm) ²	.110 (2,79)	HTR-4971-D	11-01-0068	18-22	—
4785	.218/.250 (5,35/6,35)	14-18 (2,00/0,80mm) ²	.140 (3,55)	HTR-6143	11-01-0062	14-18	—
4809	.100/.125 (2,54/3,17)	24-30 (0,20/0,05mm) ²	.062 (1,57)	HTR-2262-A	11-01-0037	24-30	—
4811	.234/.250 (5,94/6,35)	22-24 (0,35/0,20mm) ²	.100 (2,54)	HTR-4971-F	11-01-0086	22-24	—
4811-1	.234/.250 (5,94/6,35)	22-26 (0,35/0,12mm) ²	.060 (1,52)	HTR-4971-E	11-01-0085	22-26	—
4811A-3	.234/.250 (5,94/6,35)	22-24 (0,35/0,20mm) ²	.100 (2,54)	HTR-4971-E	11-01-0086	22-24	—
4811A-4	.234/.250 (5,94/6,35)	22-26 (0,35/0,12mm) ²	.060 (1,52)	HTR-4971-E	11-01-0085	22-26	—



Hand Crimp Tool

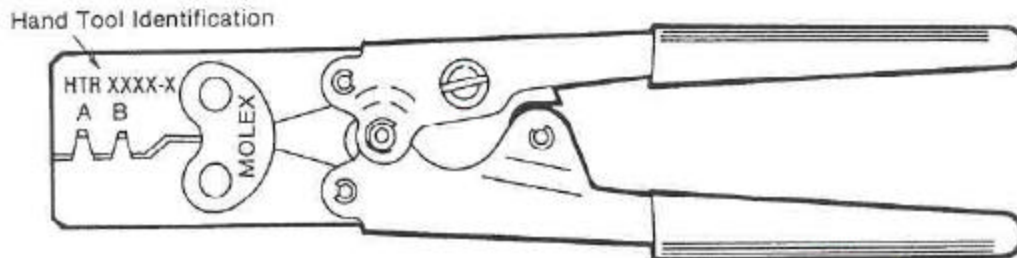

Terminal	Strip Length IN. (MM)	Wire Range AWG (XX) MM ²	Insul. Dia. Max. IN. (MM)	Hand Tool Eng. No.	Hand Tool Order No.	Crimp A	Position B
*4838	.100/.125 (2,54/3,17)	20-22 (0,50/0,35mm) ²	.095 (2,41)	HTR-2445-A	11-01-0026	20-22	—
6043	.125/.156 (3,17/3,96)	24-30 (0,20/0,05mm) ²	.070 (1,77)	HTR-2262	11-01-0006	24-30	—
6045	.125/.156 (3,17/3,96)	18-24 (0,80/0,20mm) ²	.110 (2,79)	HTR-1719-C	11-01-0008	20-24	18
6093-1	.100/.125 (2,54/3,17)	22 (0,35mm) ²	.095 (2,41)	HTR-6177	11-01-0096	—	22
6252	.100/.125 (2,54/3,17)	22-26 (0,35/0,12mm) ²	.065 (1,65)	HTR-2445-A	11-01-0026	—	24-26
*6271	.156/.218 (3,96/5,53)	18-22 (0,80/0,35mm) ²	.120 (3,04)	HTR-1031-E	11-01-0084	20-22	18
6308	.156/.218 (3,96/5,53)	24-30 (0,20/0,05mm) ²	.060 (1,52)	HTR-2262	11-01-0006	24-30	—
*6310	.156/.218 (3,96/5,53)	14-20 (2,00/0,50mm) ²	.140 (3,55)	HTR-1031-E	11-01-0084	—	14-20
*6361	.100/.125 (2,54/3,17)	18-22 (0,80/0,35mm) ²	.120 (3,04)	HTR-1719-C	11-01-0008	20-22	18
*6362	.100/.125 (2,54/3,17)	18-22 (0,80/0,35mm) ²	.120 (3,04)	HTR-1719-C	11-01-0008	20-22	18
*6438	.100/.125 (2,54/3,17)	20-22 (0,50/0,35mm) ²	.095 (2,41)	HTR-2445-A	11-01-0026	20-22	—
6459	.100/.125 (2,54/3,17)	24-30 (0,20/0,05mm) ²	.062 (1,57)	HTR-2262-A	11-01-0037	24-30	—
6664	.156/.218 (3,96/5,53)	22-30 (0,35/0,05mm) ²	.065 (1,52)	HTR-2262-A	11-01-0037	24-30	—
6722	.156/.218 (3,96/5,53)	12-14 (3,25/2,00mm) ²	.155 (3,94)	—	—	—	—
*6770	.125/.156 (3,17/3,96)	18-24 (0,80/0,20mm) ²	.110 (2,79)	HTR-1719-C	11-01-0008	20-24	18
6772	.125/.156 (3,17/3,96)	18-24 (0,80/0,20mm) ²	.110 (2,79)	HTR-1719-C	11-01-0008	20-24	18
6778	.100/.125 (2,54/3,17)	24-30 (0,20/0,05mm) ²	.082 (1,57)	HTR-7174	11-01-0093	—	26-30
6796	.125/.156 (3,17/3,96)	24-30 (0,20/0,05mm) ²	.070 (1,77)	HTR-2262-A	11-01-0037	24-30	—
6838	.100/.125 (2,54/3,17)	18-24 (0,80/0,20mm) ²	.110 (2,79)	HTR-2445-A	11-01-0106	18-24	—
*6850	.156/.218 (3,96/5,53)	16-18 (1,30/0,80mm) ²	.135 (3,42)	HTR-1031-E	11-01-0084	—	16-18
6886-2	.125/.156 (3,17/3,96)	18-24 (0,80/0,20mm) ²	.084 (2,13)	HTR-7052	11-01-0074	18-24	—



Hand Crimp Tool

Hand Tool Identification

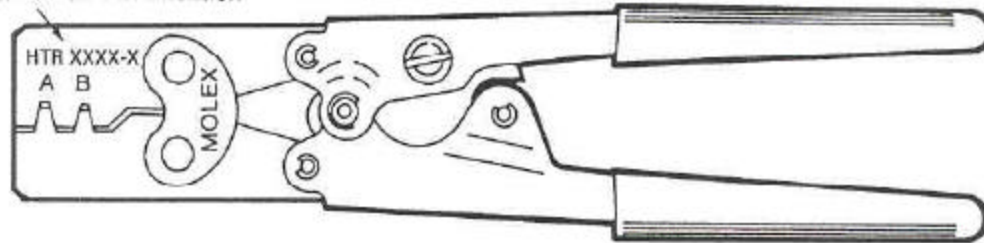

Terminal	Strip Length IN. (MM)	Wire Range AWG (XX) MM ²	Insul. Dia. Max. IN. (MM)	Hand Tool Eng. No.	Hand Tool Order No.	Crimp A	Position B
6893	.156/.218 (3,96/5,53)	24-30 (0,35/0,05mm) ²	.060 (1,52)	HTR-2262	11-01-0006	24-30	—
6894	.156/.218 (3,96/5,53)	24-30 (0,35/0,05mm) ²	.060 (1,52)	HTR-2262	11-01-0006	24-30	—
6937	.125/.156 (3,17/3,96)	20-24 (0,50/0,20mm) ²	—	HTR-7064	11-01-0100	20-24	—
*7238	.156/.218 (3,96/5,53)	14-18 (2,00/0,80mm) ²	.140 (3,55)	HTR-1031-E	11-01-0084	—	14-18
*7239	.156/.218 (3,96/5,53)	14-18 (2,00/0,80mm) ²	.140 (3,55)	HTR-1031-E	11-01-0084	—	14-18
7242	.125/.156 (3,17/3,96)	22-30 (0,35/0,05mm) ²	.060 (1,52)	HTR-2445-A	11-01-0026	—	24-30
*7258	.100/.125 (2,54/3,17)	22-26 (0,35/0,12mm) ²	.060 (1,52)	HTR-2445-A	11-01-0026	—	22-26
7291	.125/.156 (3,17/3,96)	18-24 (0,80/0,20mm) ²	.110 (2,79)	HTR-1719-C	11-01-0008	20-24	18
7293	.156/.218 (3,96/5,53)	24-30 (0,20/0,05mm) ²	.060 (1,52)	HTR-2262	11-01-0006	24-30	—
7319	.187/.218 (4,74/5,53)	18-22 (0,80/0,35mm) ²	.095 (2,41)	HTR-7093	11-01-0082	18-22	—
*7423	.156/.218 (3,96/5,53)	16-22 (1,30/0,35mm) ²	.120 (3,04)	HTR-1031-E	11-01-0084	20-22	16-18
7430	.100/.125 (2,54/3,17)	22-26 (0,35/0,12mm) ²	.095 (2,41)	HTR-8502	11-01-0104	—	22-26
7486	.100/.125 (2,54/3,17)	22-24 (0,35/0,20mm) ²	.050 (1,27)	HTR-7123	11-01-0091	—	Single Wire 22-24
7499	.125/.156 (3,17/3,96)	22-24 (0,35/0,20mm) ²	.050 (1,27)	HTR-2262	11-01-0006	24-30	—
7511	.100/.125 (2,54/3,17)	22-24 (0,35/0,20mm) ²	.050 (1,27)	HTR-7123	11-01-0091	Double Wire 22-24	—
7676	.140/.187 (3,55/4,74)	14-22 (2,00/0,35mm) ²	.140 (3,55)	HTR-2450	11-01-0023	18-22	14-18
7879	.100/.125 (2,54/3,17)	24-30 (0,20/0,05mm) ²	.060 (1,52)	HTR-2262-A	11-01-0037	24-30	—
*8058	.156/.218 (3,96/5,53)	18-22 (0,80/0,35mm) ²	.140 (3,55)	HTR-1031-E	11-01-0084	18-22	—
8662	.125/.156 (3,17/3,96)	18-22 (0,80/0,35mm) ²	.100 (2,79)	HTR-1719-C	11-01-0008	20-24	18
8818	.100/.125 (2,54/3,17)	18-22 (0,80/0,35mm) ²	.095 (2,40)	HTR-2445-A	11-01-0026	18-22	—
8960	.100/.125 (2,54/3,17)	18-24 (0,80/0,20mm) ²	.095 (2,40)	HTR-1719-C	11-01-0008	20-24	18