



M68EVB908QL4

Development Board for Motorola MC68HC908QL4

CONTENTS

CAUTIONARY NOTES	3
TERMINOLOGY	3
FEATURES	4
GETTING STARTED	5
REFERENCE DOCUMENTATION	5
M68EVB908QL4 STARTUP	6
M68EVB908QL4 OPERATION	6
MEMORY MAP	6
POWER SUPPLY	7
<i>PWR_SEL Option</i>	7
+5V_EN Option	7
POWER Indicator	7
PWR - Power Jack	7
U1 AND U2 SOCKETS	7
USER_COMPONENTS	8
JP1 USER OPTIONS	8
RESET Switch	8
IRQ Switch	8
RV1 User Potentiometer	8
MON08 DEBUG PORT	9
MON_EN Option	9
CLK_EN Option	9
X1 CLOCK OSCILLATOR	9
LIN-J1 / J2 PORTS	10
LIN_EN Option	10
WAKE Switch	10
LIN Connectors and Options	11
MC68HC980QL4 PORT CONNECTORS	11
MCU_PORT	11
CYCLONE PORT	12
TROUBLESHOOTING	12
M68EVB908QL4 SCHEMATIC	13
ERRATA	13

Cautionary Notes

- 1) Electrostatic Discharge (ESD) prevention measures should be applied whenever handling this product. ESD damage is not a warranty repair item.
- 2) Axiom Manufacturing reserves the right to make changes without further notice to any products to improve reliability, function or design. Axiom Manufacturing does not assume any liability arising out of the application or use of any product or circuit described herein; neither does it convey any license under patent rights or the rights of others.
- 3) EMC Information on the M68EVB908QL4 board:
 - a) This product as shipped from the factory with associated power supplies and cables, has been tested and meets with requirements of CE and the FCC as a **CLASS A** product.
 - b) This product is designed and intended for use as a development platform for hardware or software in an educational or professional laboratory.
 - c) In a domestic environment this product may cause radio interference in which case the user may be required to take adequate prevention measures.
 - d) Attaching additional wiring to this product or modifying the products operation from the factory default as shipped may effect its performance and also cause interference with other apparatus in the immediate vicinity. If such interference is detected, suitable mitigating measures should be taken.

Terminology

This development board applies option selection jumpers. Terminology for application of the option jumpers is as follows:

Jumper on, in, or installed = jumper is a plastic shunt that fits across 2 pins and the shunt is installed so that the 2 pins are connected with the shunt.

Jumper off, out, or idle = jumper or shunt is installed so that only 1 pin holds the shunt, no 2 pins are connected, or jumper is removed. It is recommended that the jumpers be idled by installing on 1 pin so they will not be lost.

This development board applies hard wired option selections (JP2). These option selections apply a circuit trace between the option pads to complete a default connection. This type connection places an equivalent Jumper Installed type option. The circuit trace between the option pads maybe cut with a razor blade or similar type knife to isolate the default connection provided. Applying the default connection again can be performed by installing the option post pins and shunt jumper, or by applying a wire between the option pads.

FEATURES

The M68EVB908QL4 is an evaluation or development board for the MC68HC908QL4 microcontroller. Development of applications is quick and easy with the included DB9 serial cable, sample software tools, examples, and debug monitor MON08. The prototyping area provides space to apply the CPU I/O to your needs. The Cyclone port is provided for high-end development tool application.

Features:

- ◆ MC68HC908QL4 CPU
 - * 4K Byte Flash
 - * 128 Bytes Ram
 - * 14 I/O lines (16 pins)
 - * 2 channel 16 bit TIM Timer
 - * 6 Channel 10 BIT A/D
 - * LIN Slave Serial Port
 - * 6 Key Wake-up Ports
 - * MON08 debug monitor ROM
 - * Internal Clock generator
 - * up to 8Mhz operation
- ◆ 9.8304MHz clock oscillator
- ◆ ZIF sockets for TSSOP or DIP packages
- ◆ Regulated 5V power supply
- ◆ LIN Ports with transceiver (MC33661)
- ◆ DEBUG Port – Serial RS232 MON08 interface
- ◆ CYCLONE Debug Cable Port
- ◆ Power Indicator
- ◆ User Components Provided
 - * 1 LED Indicators (PTB0)
 - * 2 Push Switches (PTA2-3)
 - * Potentiometer (PTB3)
- ◆ MCU Port connector provides all I/O
- ◆ Large 1" x 3" Prototype Area
- ◆ Supplied with DB9 Serial Cable, LIN connection cable, Utility Support disk (CD), Manuals, and Wall plug type power supply.

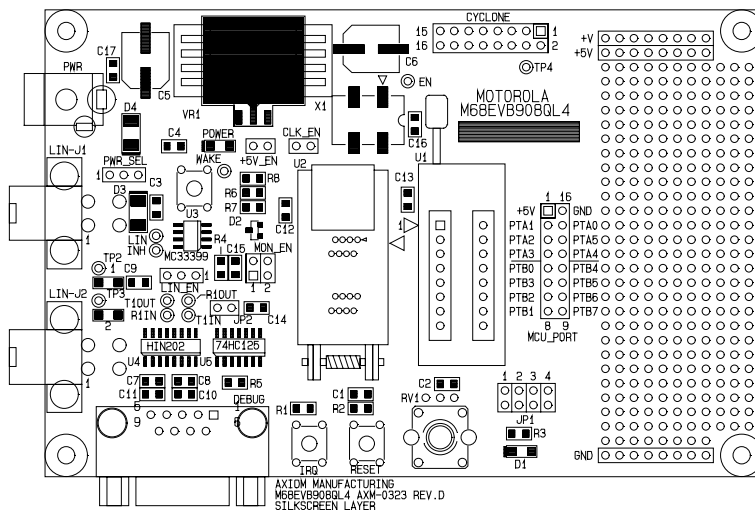

M68EVB908QL4

Specifications:

Board Size 3.250" x 5.0"
 Power Input: +6 - +20VDC, 9VDC typical
 Current Consumption: 30ma @ 9VDC input

The MON08 monitor is available by serial interface to host based development environments for source level debugging operations. Access to the MON08 is by the CYCLONE cable or the DEBUG port. PC hosting software is required to apply the MON08 debug ports. See the provided software samples for installation and application directions.

GETTING STARTED

The M68EVB908QL4 single board computer is a fully assembled, fully functional development board for the Motorola MC68HC908QL4 microcontroller. Provided with wall plug power supply and serial cable. Support software for this development board is provided for Windows 95/98/NT/2000/XP operating systems.

Development board users should also be familiar with the hardware and software operation of the target HC08 device, refer to the provided Motorola User Guide for the device and the HC08 Reference Manual for details. The development board purpose is to assist the user in quickly developing an application with a known working environment or to provide an evaluation platform for the target HC08. Users should be familiar with memory mapping, memory types, and embedded software design for the quickest successful application development.

Application development maybe performed by applying MON08 monitor with the DEBUG port or by applying the CYCLONE cable with supporting host software. The monitor provides an effective and low cost debug method.

The MON08 serial monitor is provided in the HC08 device internal ROM memory and applies some HC08 resources for operation. See the MON08 section of the QL4 user manual from Motorola for complete details. After the user application is tested under monitor control, the code can be configured for dedicated operation and programmed into the device.

Reference Documentation

Reference documents are provided on the support CD in Acrobat Reader format.

CD:\Documents\Reference\M68HC908QL4.pdf – QL4 device user manual

CD:\Documents\Reference\CPU08RM.pdf – CPU08 core user manual with instruction set

CD:\Documents\Schematics\M68EVB908QL4_SCH_D.pdf – M68EVB908QL4 schematics

CD:\Documents\Manuals\M68EVB908QL4man.pdf – This user manual

The most recent Motorola documents can be found at this link:

<http://e-www.motorola.com/>

Look under the products – microcontrollers selection to find related documents

M68EVB908QL4 Startup

Follow these steps to connect and power on the board for the default Monitor operation.

Note: LIN slave communication firmware is installed in the QL4 flash at the factory. Refer to Motorola application note AN2633/D LIN Drivers for SLIC Module of MC68HC908QL4 for details. This application note and software example may be found on the Motorola web site.

- 1) Inspect the U1 and U2 sockets for proper installation of a QL4 device in one of the sockets.
- 2) Install the provided Wall-Plug power supply in an available power outlet and connect to the EVB PWR jack. If the POWER Indicator is not ON, check the following:
 - PWR_SEL option jumper installed in the 1-2 position.
 - +5V_EN option jumper installed on both pins.
- 3) Install MON08 hosting software for applying the DEBUG port on the host PC.
- 4) Connect the M68EVB908QL4 board DEBUG serial connector to the host PC COM port with the provided serial cable.
- 5) Launch the host MON08 software and mass or bulk erase the QL4 flash to unsecure the device flash. This is required if the QL4 flash is programmed and the security is unknown.
- 6) Perform a MON08 restart procedure to start a debug session. Follow instructions and examples provided with the hosting software.

M68EVB908QL4 OPERATION

The M68EVB908QL4 board provides input and output features to assist in application development. These features may be isolated from the applied HC08 I/O ports by associated option jumpers. This allows alternate use of the HC08 I/O ports for other application and connection on the MCU_PORT connector. Caution should be observed so that the HC08 I/O port pin applied to an on board feature is not also applied to external components by the user.

MEMORY MAP

The EVB board does not provide any expansion memory or memory mapped peripherals. Refer to the HC08 device user manual for device memory location and type.

POWER SUPPLY

Input power is applied by external connection to the PWR power jack or LIN-J1/2 port connectors. The input source is selected by the PWR_SEL option jumper. The regulator is protected from reverse voltage application by diode D3 or D4. Input voltage is regulated to +5V supply by VR1 and enabled to the development board circuits by the +5V_EN option jumper installed. The POWER indicator will light when +5V is available.

PWR_SEL Option

The PWR_SEL option provides EVB board input power source selection between the LIN port connectors and primary input PWR jack. Default position is jumper installed on pins 1-2 for PWR jack input. The user may elect to move this option jumper to position 2-3 when applying the LIN ports on a LIN network that provides the +V source.

+5V_EN Option

The +5V_EN option provides board power enabled or disabled control. Default position is jumper installed on both pins. The user may elect to remove this option jumper when a Cyclone development cable is applied so that the cable can control the power up sequence.

POWER Indicator

The POWER indicator will be ON if +5V is available on the EVB board. The indicator may have a visible indication if the power supply is below +5V and out of regulation also.

PWR - Power Jack

PWR provides the default power input to the board. The power jack accepts a standard 2.0 ~ 2.1mm center barrel plug connector (positive voltage center) to provide the +V input supply of +6 to +20 VDC (+9VDC typical).

+Volts, 2mm center

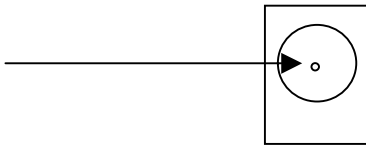

U1 and U2 Sockets

U1 and U2 provide Zero Insertion Force (ZIF) type sockets for installing the QL4 device. Only one QL4 may be installed on the development board at a time. U1 provides a Dual In-Line (DIP) type package mount and will also allow SOIC type packages to be applied with a SOIC / DIP adapter (Logical Systems part # PA16SO1-03-3 or similar). U2 offers the TSSOP package type mount. Use caution to verify the device PIN 1 location when installing in the sockets.

USER_COMPONENTS

Two push switches, potentiometer, and LED indicator are provided for user application.

JP1 USER OPTIONS

The JP1 option block provides a method to enable or connect user components to be applied with the HC08 I/O ports. The development board user should be familiar with the input and output application so that port conflicts do not occur. Following is the option connection reference table:

POSITION	USER COMPONENT	HC08 PORT	PORT DIRECTION	ALTERNATE PORT
1	IRQ Push Switch	PTA2/IRQ*/KBI2	Input	MCU PORT pin 3, MON_EN, CYCLONE
2	RESET Push Switch	PTA3/RST*/KBI3	Input	MCU PORT pin 4
3	RV1 Potentiometer	PTB3/AD5	Input	MCU PORT pin 6
4	D1 Indicator (active low)	PTB0/TCH0	Output	MCU PORT pin 5

Note: RESET switch, IRQ switch, and LED indicator are active logic low.

RESET Switch

The RESET switch applies an active low signal to the HC08 PTA3/RST*/KBI3 pin if the JP1 option position 2 is installed. When applying the CYCLONE cable and port, this jumper should be installed to enable the pull-up resistor on the RESET signal.

IRQ Switch

The IRQ switch applies an active low signal to the HC08 PTA2/IRQ*/KBI2 pin if the JP1 option position 1 is installed.

RV1 User Potentiometer

The User Potentiometer provides an adjustable linear voltage from 0 to 5V. The voltage signal is made available to HC08 port PTB3 / AD5 analog input by the JP1 position 3 option jumper installed. The HC08 ADC module can measure the input voltage to allow user application response to the input voltage level.

MON08 DEBUG PORT

The DEBUG port provides standard 9 pin connection with RS232 type serial interface to the HC08 MON08 debug monitor. The MON_EN and CLK_EN options should be installed prior to applying power to the EVB to apply the DEBUG port. HC08 ports PTA0, PTA2, and PTA5 are applied to operate this port. Monitor communication is provided without additional features such as BREAK or RESET. Hosting software is required to communicate with the monitor on this port. Do not apply the DEBUG port and CYCLONE cable at the same time. Refer to the M68EVB908QL4 schematic drawing for circuit and connector connections.

MON_EN Option

The MON_EN 1 and 2 option jumpers provide HC08 MON08 signals to the DEBUG Port. Install the jumpers on both pins to enable the signals.

MON_EN 1 – Enables the 9V VTT supply to HC08 port PTA2/IRQ to enable monitor mode on power up.

MON_EN 2 – Enables the MON08 communication from HC08 port PTA0 to the DEBUG port.

CLK_EN Option

The CLK_EN option jumper provides for a 9.8304Mhz clock to be applied to the HC08 PTA5/OSC1 pin. This clock source is required for MON08 debug monitor operation via the DEBUG port. Install the jumper on both pins to enable the 9.8304 clock signal to the HC08.

X1 CLOCK OSCILLATOR

The X1 clock Oscillator is provided to allow default monitor mode (MON08) operation. When the MON08 debug monitor is to be applied, the X1 clock should be optioned to provide the clock source. The CLK_EN option jumper installed will provide the X1 clock source to the HC08 device pin PTA5. User should also note that the MCU_PORT may provide a signal to drive the clock signal on PTA5. In this case, the CLK_EN option should not be installed.

LIN-J1 / J2 PORTS

The LIN ports provide parallel connectors for attaching a LIN network. Providing two connectors enables the user to either connect additional slave nodes or monitoring / test tools to the board without special wiring harness creation. The QL4 device provides a LIN Slave type node on the LIN Network. A LIN physical layer transceiver (MC33661, or similar) is provided between the QL4 device and the LIN network connectors. Refer to the MC33661 data sheet for complete details of transceiver operation. The following diagram represents the LIN connection:

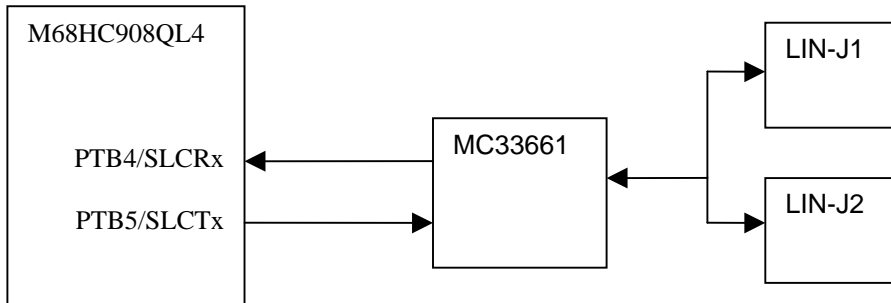

The LIN interface provides optional features of Enable control (LIN_EN option), Wake switch, and input power source option - PWR_SEL. See the PWR_SEL option in the power supply section of this manual for information on this option.

LIN_EN Option

The LIN_EN option allows enable control of the LIN transceiver. With a transceiver such as the MC33661, software control of the EN pin allows the user to set the slew rate control of the transceiver. This feature allows the EMC characteristics of the physical layer to be tuned to the needs of the application. Three options are available:

LIN_EN = OPEN: (No option jumper installed) The transceiver is disabled and in sleep mode, no LIN output messages will be possible. Pin 2 of the option pins can be wired to any available HC08 port to provide the enable signal. The WAKE switch maybe applied to enable the transceiver also.

LIN_EN = 1-2 jumper position: QL4 port PBT7 provides transceiver output control. PTB7 output high will enable the transceiver to allow LIN messages.

LIN_EN = 2-3 jumper position: Transceiver is always enabled. Port PTB7 maybe applied for other purposes with this option setting.

WAKE Switch

The WAKE switch applies the Wake up function of the transceiver. With LIN_EN option open, the switch will wake-up the transceiver. Wake also has a test pad for remote connections.

LIN Connectors and Options

The LIN network connectors (LIN-J1 and LIN-J2) provide a standard pin configuration with a network option position.

Front view (looking into connector from outside of board edge)

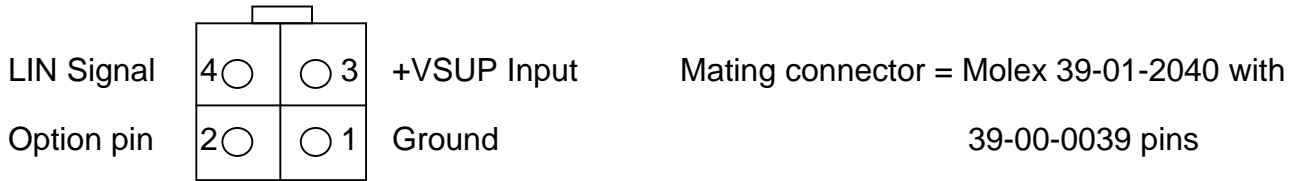

Option pin 2 on the LIN connectors provides an additional ground or Test Pad to apply another signal with the network. Test pad TP2 provides option access to LIN-J1 and TP3 provides option access to LIN-J2. Option pad set 1 and 2 will provide connections to ground for LIN_J1 and LIN-J2 option pin 2 respectfully.

MC68HC980QL4 PORT CONNECTORS

MCU_PORT

The MCU PORT provides access to the MC68HC980QL4 I/O ports. Port configuration reflects the DIP package device pin and signal order.

+5V (VDD)	1	16	GND (VSS)
PTA1/TCH1/KBI1	2	15	PTA0/AD0/KBD0
PTA2/IRQ*/KBI2/TCLK	3	14	PTA5/OSC1/AD3/KBD5
PTA3/RST*/KBI3	4	13	PTA4/OSC2/AD2/KBI4
PTB0/TCH0	5	12	PTB4/SLCRX
PTB3/AD5	6	11	PTB5/SLCTX
PTB2/AD4	7	10	PTB6
PTB1	8	9	PTB7

Notes:

- 1) PTA0 – 2, PTA4, and PTA5 applied with CYCLONE cable if installed.
- 2) PTA0 is also the MON08 debug monitor serial I/O (MON_EN).
- 3) PTA2 provides IRQ Push Switch input (JP1) or Monitor mode entry voltage (MON_EN).
- 4) PTA3 provides RESET Push Switch input (JP1).
- 5) PTB0 provides D1 indicator output (JP1).
- 6) PTB3/AD5 provides RV1 user pot input (JP1).
- 7) PTB4 provides LIN serial input (SLCRX).
- 8) PTB5 provides LIN serial output (SLCTX).

CYCLONE PORT

The Cyclone port is a 16 pin header compatible with a Cyclone development cable. Applying this cable allows supporting host tools to load and control the QY4 during development. The MON_EN, JP1 position 1, CLK_EN, and +5V_EN option jumpers should be open when applying this port.

N/C	1	2	GND (VSS)
N/C	3	4	TP4
N/C	5	6	PTA2/IRQ*
N/C	7	8	PTA0/MON08 I/O
N/C	9	10	PTA4
N/C	11	12	PTA1
PTA5/OSC1	13	14	N/C
+5V	15	16	N/C

N/C = No connection

TROUBLESHOOTING

The M68EVB908QL4 is fully tested and operational before shipping. If it fails to function properly, inspect the board for obvious physical damage first. Verify the setup as described under GETTING STARTED and START-UP sections of this manual.

1. Verify proper installation of a MC68HC908QL4 in the U1 or U2 socket (not both).
2. Disconnect all external connections to the board except for the serial cable to the PC and the wall plug. If applying the Cyclone cable, check it's operation or remove it.
3. Verify the wall plug connections to outlet and the power connector.
4. Verify the power source is enabled and the PWR_EN option is correctly installed.
5. Verify the +5V_EN option is installed and the Power indicator is ON. You should measure +5V on the +5V_EN jumper center.
6. Contact support@axman.com by email for further assistance. Provide board name and describe the problem.

M68EVB908QL4 Schematic

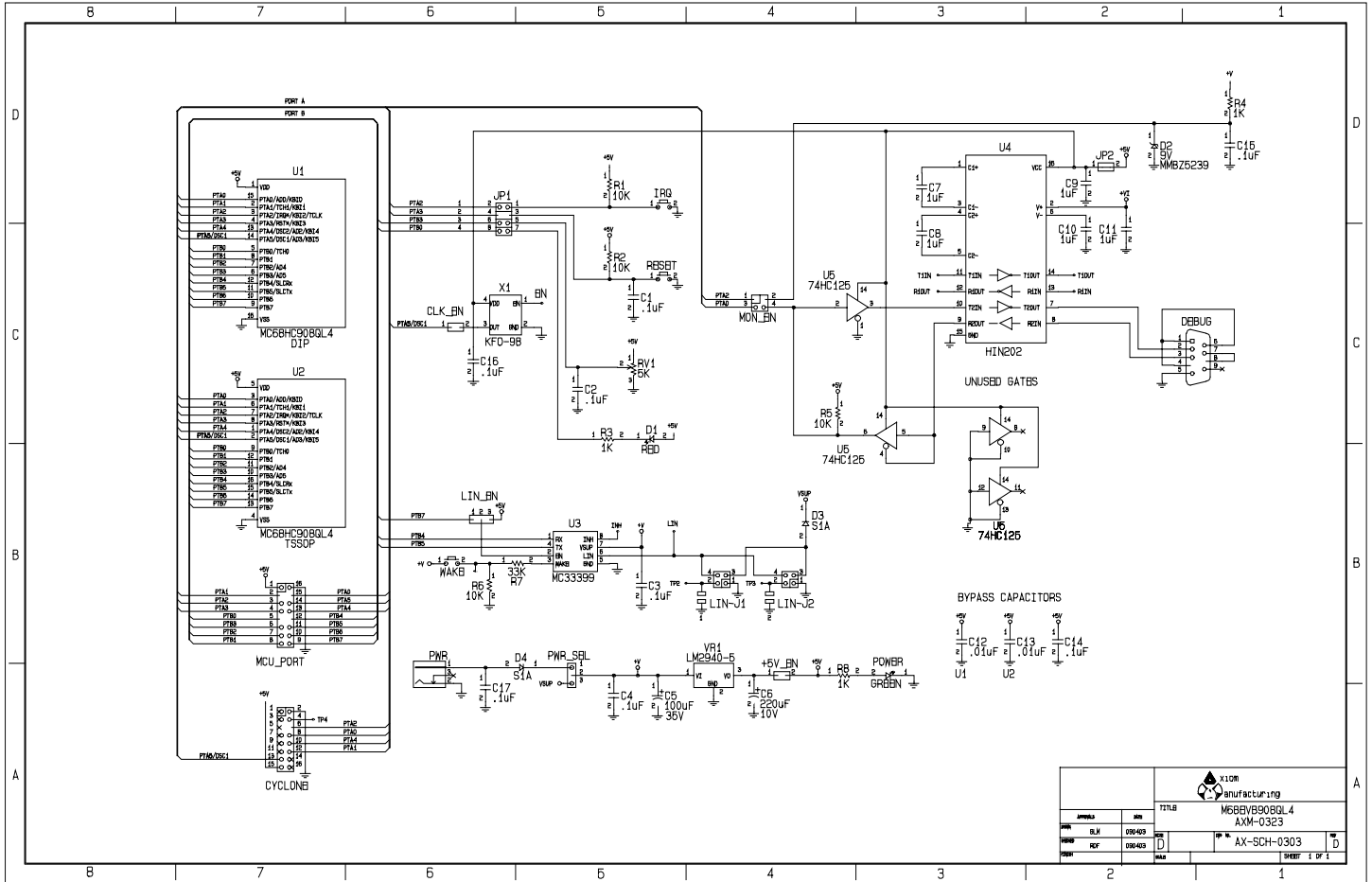

Errata

M68EVB908QL4 (AXM0323) Revision D:

- 1) PTA1 has a 100K pull-up resistor to +5V to provide DEBUG port Monitor mode entry. Not shown on Rev D schematic.
- 2) PTA4 has a 100K pull-down resistor to Ground/VSS to provide DEBUG port Monitor mode entry. Not shown on Rev D schematic.