

## 6.5 Gbps 40 × 40 Crosspoint Switch with Low Power Green Modes

Vitesse's multichannel 6.5 Gbps crosspoint switch provides a cost-effective solution for high-speed copper interconnects

### Highlights

- DC to 6.5 Gbps operation
- 40 × 40 fully non-blocking switch capability
- Protocol-independent operation
- Advanced EQ
- Low power green modes
- Small 23 mm × 23 mm form factor

### Applications

- HDMI/DVI/DisplayPort switching/routing
- Broadcast video routers
- Broadcast video switchers
- PCIe repeater applications
- Blade servers
- Storage servers
- Telecom

The VSC3340 is the industry's highest performance signal integrity crosspoint solution with low power green modes for optimal reduced power operation. The VSC3340 is uniquely capable of addressing a wide array of routing, switching, and signal integrity issues across storage, blade server, broadcast video, telecommunications, and Ethernet applications. In video applications, the VSC3340 can support HDMI, DVI, DisplayPort, or SDI HDTV protocols. The VSC3340 features a 40 × 40 non-blocking, multicasting switch core with ports running at any rate up to 6.5 Gbps. The VSC3340 architecture provides protocol-independent operation that allows each channel to run independently, and optimizes low power operation when running at lower speeds.

The VSC3340 includes both register and static programming modes. The VSC3340 incorporates Vitesse's fourth-generation input equalization and pre-emphasis I/O capability for the industry's latest generation protocols. The device can perform signal fanout, loopback, and protection switching. It can also regenerate signals severely compromised by transmission losses. Vitesse's industry-proven equalization provides highly effective compensation for deterministic jitter across a wide range of high-speed interconnect applications.

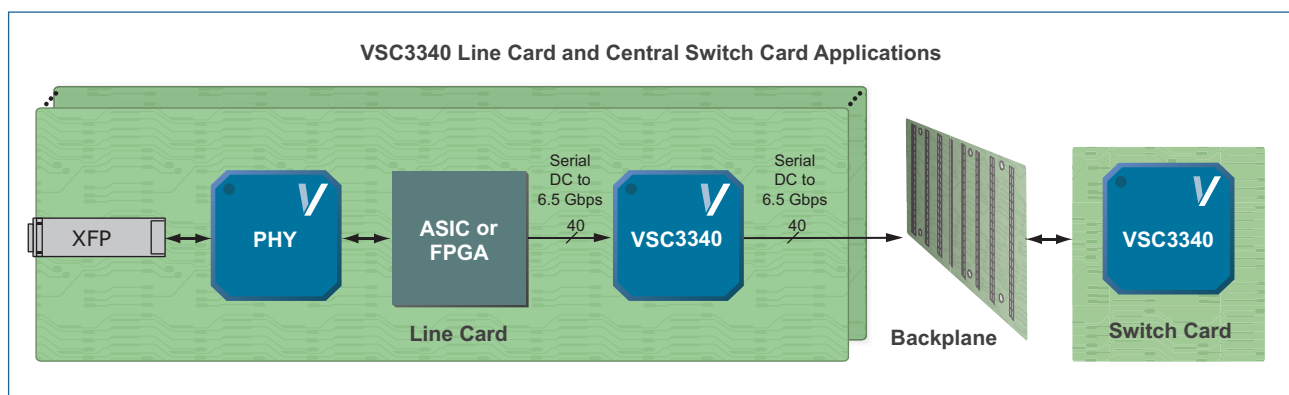

Using the VSC3340 in high-speed line cards ensures best-in-class I/O performance up to 6.5 Gbps with EQ technology to compensate for connector, backplane, and FR-4 loss. The VSC3340's small 23 mm × 23 mm form factor enables use in line card or central switch applications.

## Speed and Protocol Support

- 6.5 Gbps non-return-to-zero (NRZ) data bandwidth
- Protocol-independent low power green modes when used at lower data rates

## Architecture

- Fully non-blocking and multicasting switch core
- Loss of Signal (LOS) detection and forwarding (supports out-of-band signaling)
- Fully asynchronous operation with <1 ns latency
- 40 × 40 switch core enables signal fanout, loopback, and protection switching

## Signal Integrity

- Multiple time-constant programmable input and output equalization
- Wide equalization adjustment range
- Input EQ of 26 dB at 6.5 Gbps
- 9 dB of pre-emphasis

## Key Specifications

- 6.5 Gbps NRZ per channel data rate
- 2.5 V power supply
- 23 mm × 23 mm flip chip ball grid array package

## Related Vitesse Products

Visit [www.vitesse.com](http://www.vitesse.com) for information about these related Vitesse products:

- Crosspoint Switches
- Ethernet MACs
- Mux, Demux, and Transceivers
- Electronic Dispersion Compensation CDRs

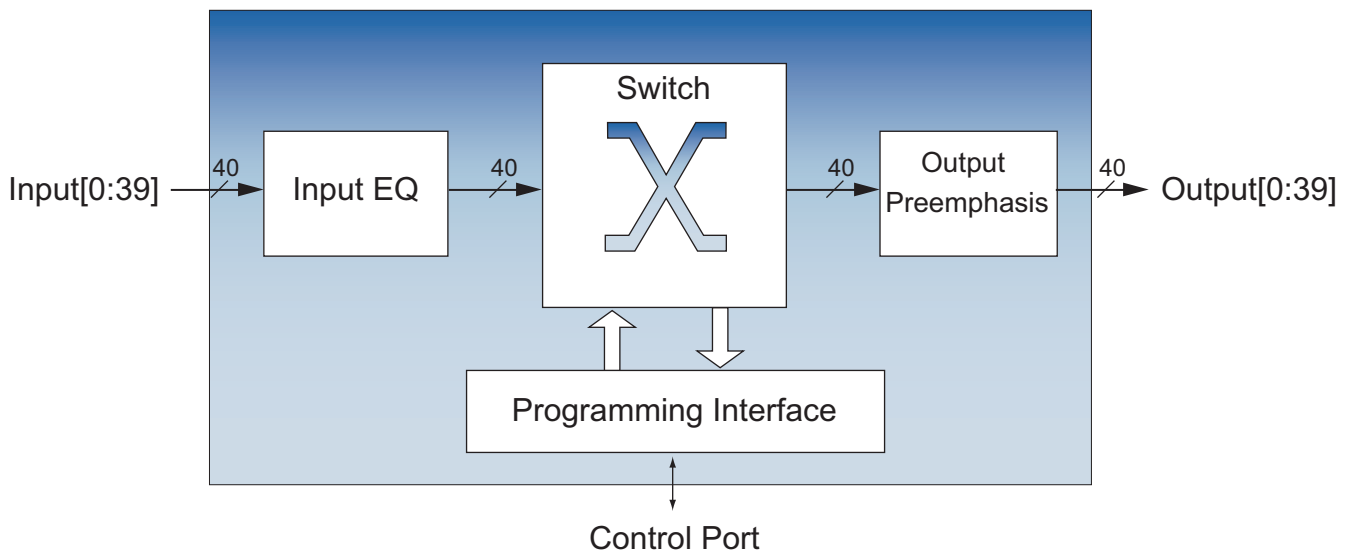

## Vitesse Semiconductor Corporation

741 Calle Plano • Camarillo, CA 93012 USA • Tel: +1.800.VITESSE • +1.805.388.3700 • Fax: +1.805.987.5896 • [www.vitesse.com](http://www.vitesse.com)

© 2010 by Vitesse Semiconductor Corporation. VPPD-02565 Revision 1.0. Vitesse Semiconductor Corporation ("Vitesse") retains the right to make changes to its products or specifications. As such, all information in this document, including descriptions of features, functions, performance, technical specifications and availability, is subject to change without notice at any time, and Vitesse assumes no responsibility for use of any information herein. Nothing contained herein conveys to the purchaser of microelectronic devices any license under the patent or any other intellectual property rights of any manufacturer. Vitesse®, and numerous other trademarks, are trademarks of Vitesse in the United States and/or other jurisdictions. Other trademarks used herein that are not the property of Vitesse are the property of their respective owners. While Vitesse products support IEC 60825, use of Vitesse products does not ensure compliance to IEC 60825. Buyers are responsible for ensuring compliance to IEC 60825. Buyers must fully indemnify Vitesse for any damages resulting from non-compliance to IEC 60825.