

SECTION A-A

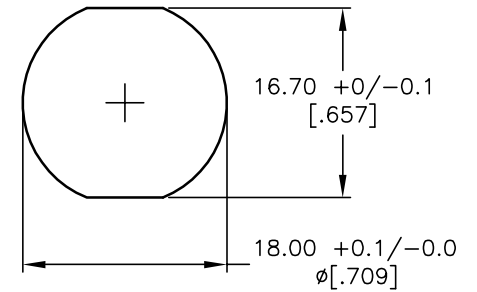

RECOMMEND PANEL MOUNTING

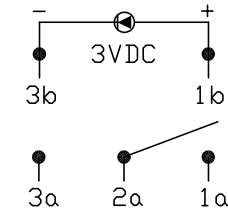
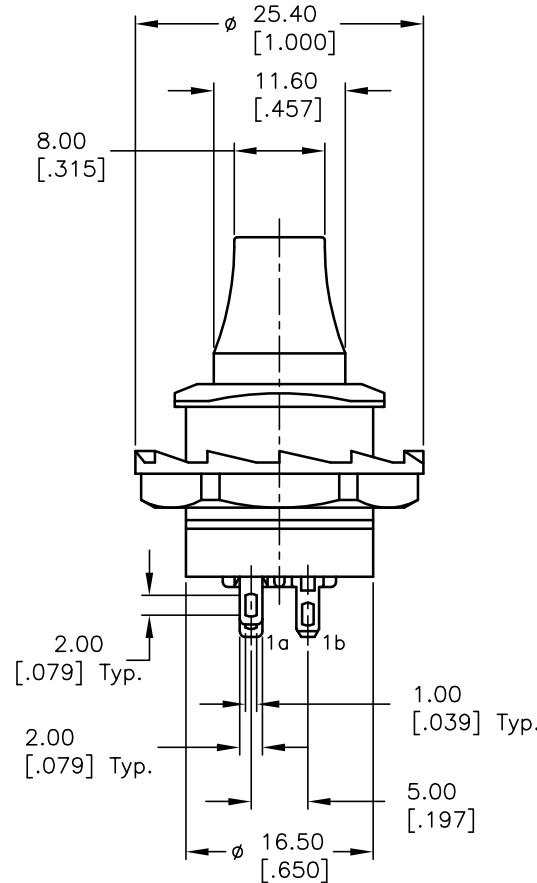
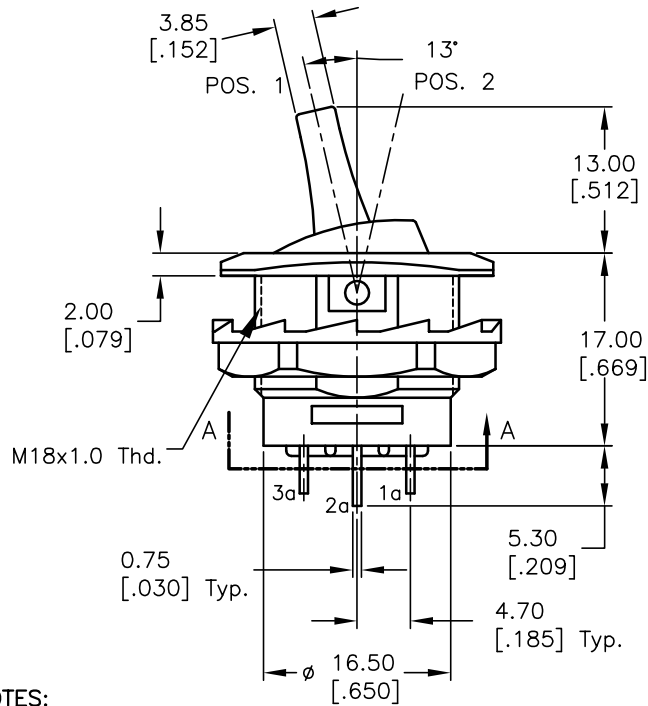

CIRCUIT: 5P; SPDT
CONTACT CONFIGURATION

SWITCH FUNCTION	
POS. 1	POS. 2
ON	ON
2a-1a	2a-3a

NOTES:

1. ALL DIMENSIONS IN MM [INCH]
2. GENERAL TOLERANCE: 0.0=±0.4
0.00=±0.25
3. TERM. NOS. FOR REF. ONLY
4. RATING: 10A 125V; 6A 250V AC
5. CONTACT RESISTANCE: 50m ohm max.
6. INSULATION RESISTANCE: DC 500V, 100M ohm min.
7. DIELECTRIC STRENGTH: AC 1500V 1 minute

E-SWITCH®

TITLE

RR3405CL-RED

REV.	ECN No.	DESCRIPTION	DATE	CHKD
A	10523	RELEASED FOR PRODUCTION		

SCALE

1.5:1

DATE

2/9/00

DR

MM

DWG

F030009

REV

A

THE INFORMATION CONTAINED IN THIS DOCUMENT IS PROPRIETARY TO E-SWITCH AND IS NOT TO BE COPIED OR TRANSFERRED