

CAN-SPI™

Manual

All Mikroelektronika's development systems feature a large number of peripheral modules expanding microcontroller's range of application and making the process of program testing easier. In addition to these modules, it is also possible to use numerous additional modules linked to the development system through the I/O port connectors. Some of these additional modules can operate as stand-alone devices without being connected to the microcontroller.

Additional Board

 **MikroElektronika**

SOFTWARE AND HARDWARE SOLUTIONS FOR EMBEDDED WORLD ...making it simple

CAN-SPI Additional Board

The CAN protocol is compliant with ISO standard and is primarily used in serial communication. It was originally intended for applications in automotive industry, but these days it is commonly used in other industries where a high noise resistance and high level of reliability at transferring data is required.

CAN network consists of several nodes cabled together (L and H lines). There is one CAN controller in each of these nodes used to adjust standard digital signals to voltages present in the network. The *CAN-SPI* board features a transceiver MCP2551 that provides necessary signal adjustments and enables these signals to be sent/received at a rate of up to 1 Mb/s. In addition, this circuit serves as a protection against high voltages that might appear in the network (EMI, ESD, noise caused by induction, etc.). The *CAN-SPI* board also features the MCP2515 circuit used as a CAN controller that exchanges data with microcontrollers using a standard Serial Peripheral Interface (SPI).

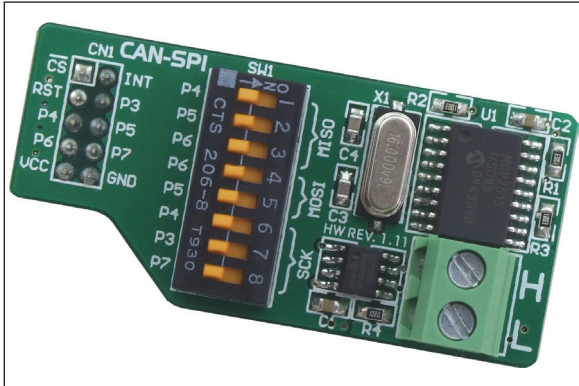

Figure 1: CAN-SPI additional board

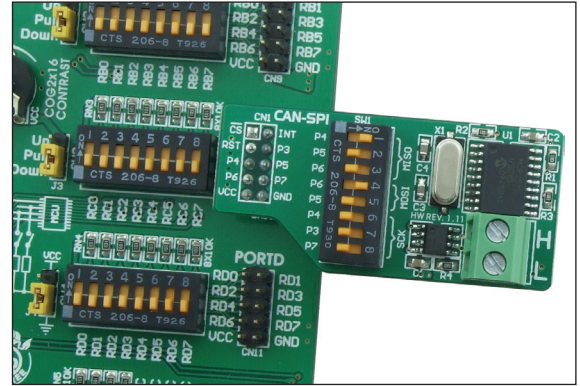

Figure 2: CAN-SPI board connected to a development system

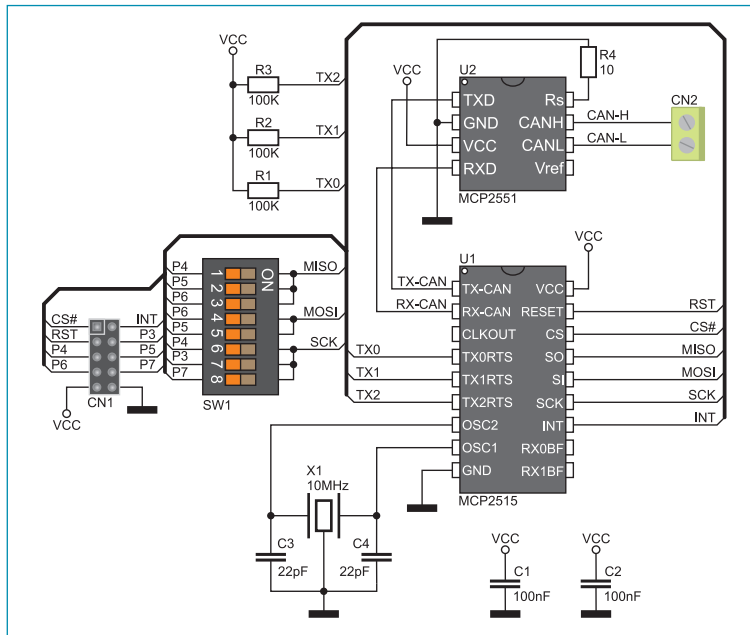

Figure 3: CAN-SPI additional board connection schematic

There are two connectors provided on the board. A 2x5 connector is used for connection with a development system the board is connected to, whereas a screw terminal with contacts marked H and L enables connection with the network. Since the board uses SPI interface for communication with microcontrollers, it may also be used with microcontrollers which are not supplied with the built-in CAN module.

DIP switch SW1 is used to select pins on the microcontroller port to be used for SPI communication (MISO, MOSI and SCK lines).