

# SPECIFICATIONS

PARAMETERS	VALUES	UNIT
RATED VOLTAGE	3.6	V0-p
OPERATING VOLTAGE RANGE	2 ~ 4	V0-p
RATED CURRENT (MAX)	100	mA
COIL RESISTANCE	16 ± 3	OHM
MINIMUM SPL @ 10 CM	85 (91 AVG)	dBA
RESONANT FREQUENCY	2,730 ± 500	Hz
OPERATING TEMPERATURE	-30 ~ +70	°C
STORAGE TEMPERATURE	-40 ~ +85	°C
HOUSING MATERIAL	LCP	-
TERMINAL MATERIAL	Sn PLATED BRASS	-
WEIGHT	0.8	grams

THIS DOCUMENT CONTAINS DATA PROPRIETARY TO PROJECTS UNLIMITED, INC. ANY USE OR REPRODUCTION, IN ANY FORM, WITHOUT PRIOR WRITTEN PERMISSION OF PROJECTS UNLIMITED, INC. IS PROHIBITED.  
©2003, Projects Unlimited Inc.

# REVISION HISTORY

LTR	DESCRIPTION	DATE	APPROVED
-	RELEASED FROM ENGINEERING	9/2/2016	

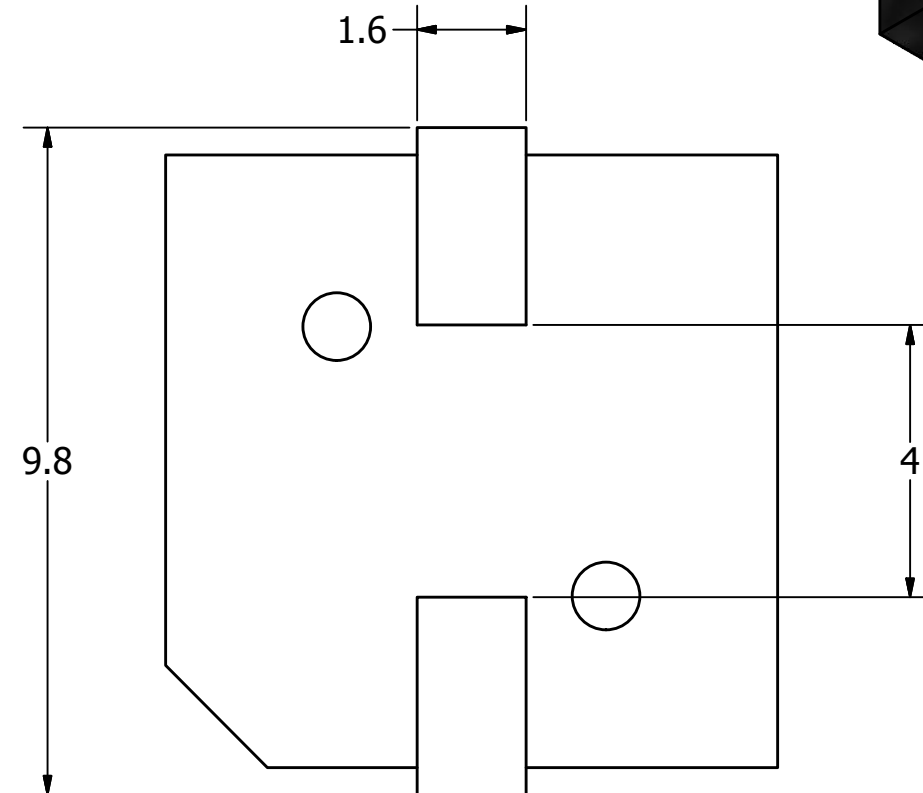
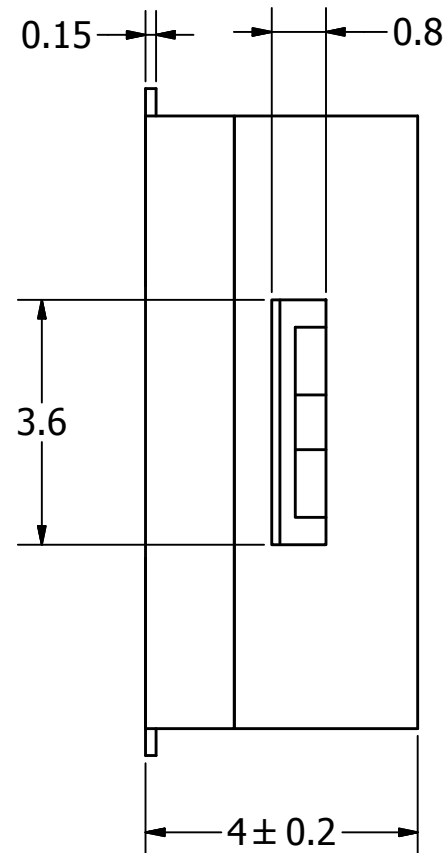
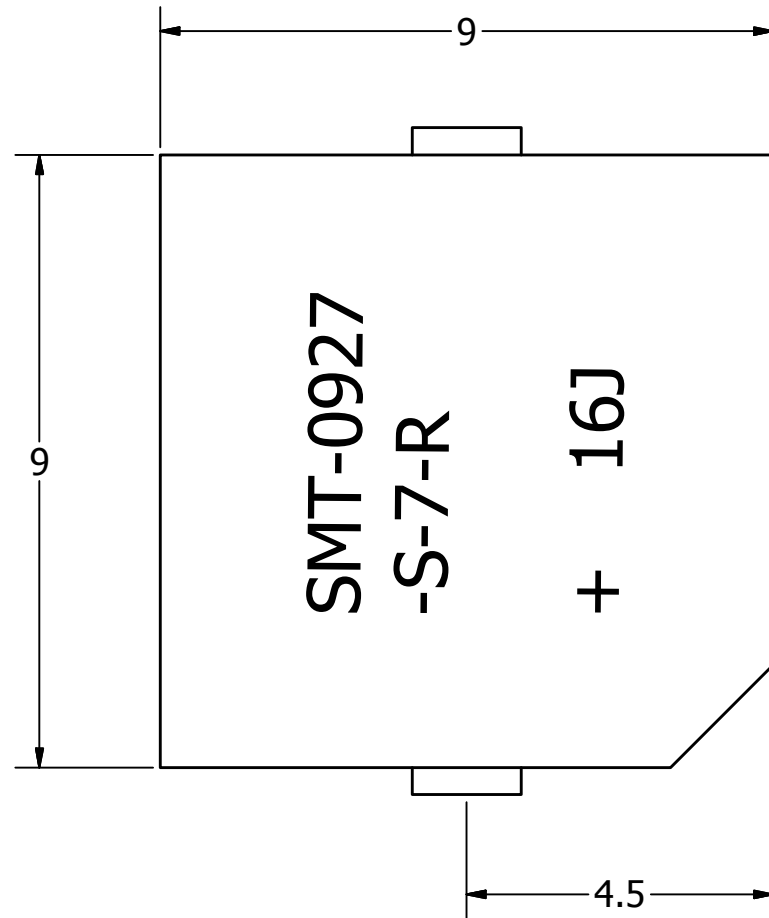
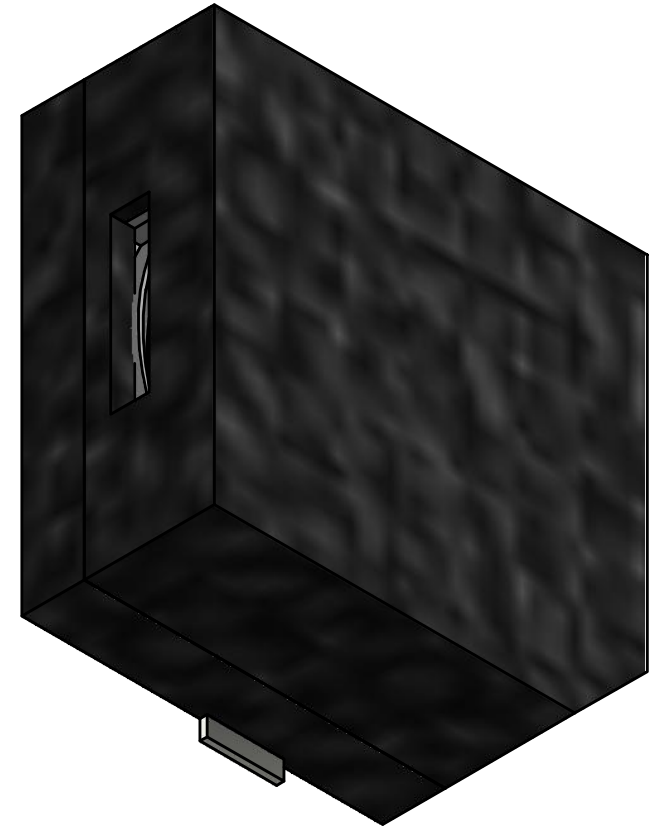

## NOTES:

1. ALL DIMENSIONS ARE IN MILLIMETERS.
2. SPECIFICATIONS SUBJECT TO CHANGE OR WITHDRAWL WITHOUT NOTICE.
3. THIS PART IS RoHS 2011/65/EU COMPLIANT.

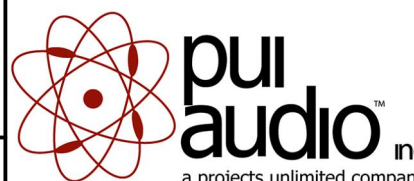
UNLESS OTHERWISE SPECIFIED: DIMENSIONS ARE IN MILLIMETERS, TOLERANCES ARE ±0.5 AND ANGLES ARE ±3°.	SIZE <b>A3</b>	Designed by	Date	Checked by	Date	Approved by	Date	Drawn Date	
		M.V.	9/2/2016	M.V.	9/2/2016	B.R.	9/2/2016	9/2/2016	
SMT-0927-S-7-R.idw				<b>SMT-0927-S-7-R</b>					
		Transducer (Electro-Mech)				Edition		Sheet	
						-		1 / 1	