

THIS DRAWING IS UNPUBLISHED. RELEASED FOR PUBLICATION
 © COPYRIGHT - By - ALL RIGHTS RESERVED.

LOC		DIST		REVISIONS			
P	LTR	DESCRIPTION		DATE	DWN	APVD	
AF	50	D1	ECR-13-016672	25OCT13	PKS	RRP	

- 1 CONTINUOUS STRIP ON REELS WITH TERMINALS LOCATED ON 6.86±0.08 [.270±.003] CENTERS
- 2 SLOT ACCEPTS 0.57-0.81mm [#23-#20] AWG COPPER MAGNET WIRE. TWO WIRES OF THE SAME SIZE MAX PER SLOT FOR #23 GAGE. ONE WIRE MAX PER SLOT FOR #22-#20 AWG
- 3 IDENTIFICATION NUMBER 15 FOR THE MAGNET WIRE SLOT SIZE
- 4 0.25[.010] MAX CARRIER CUT-OFF TABS

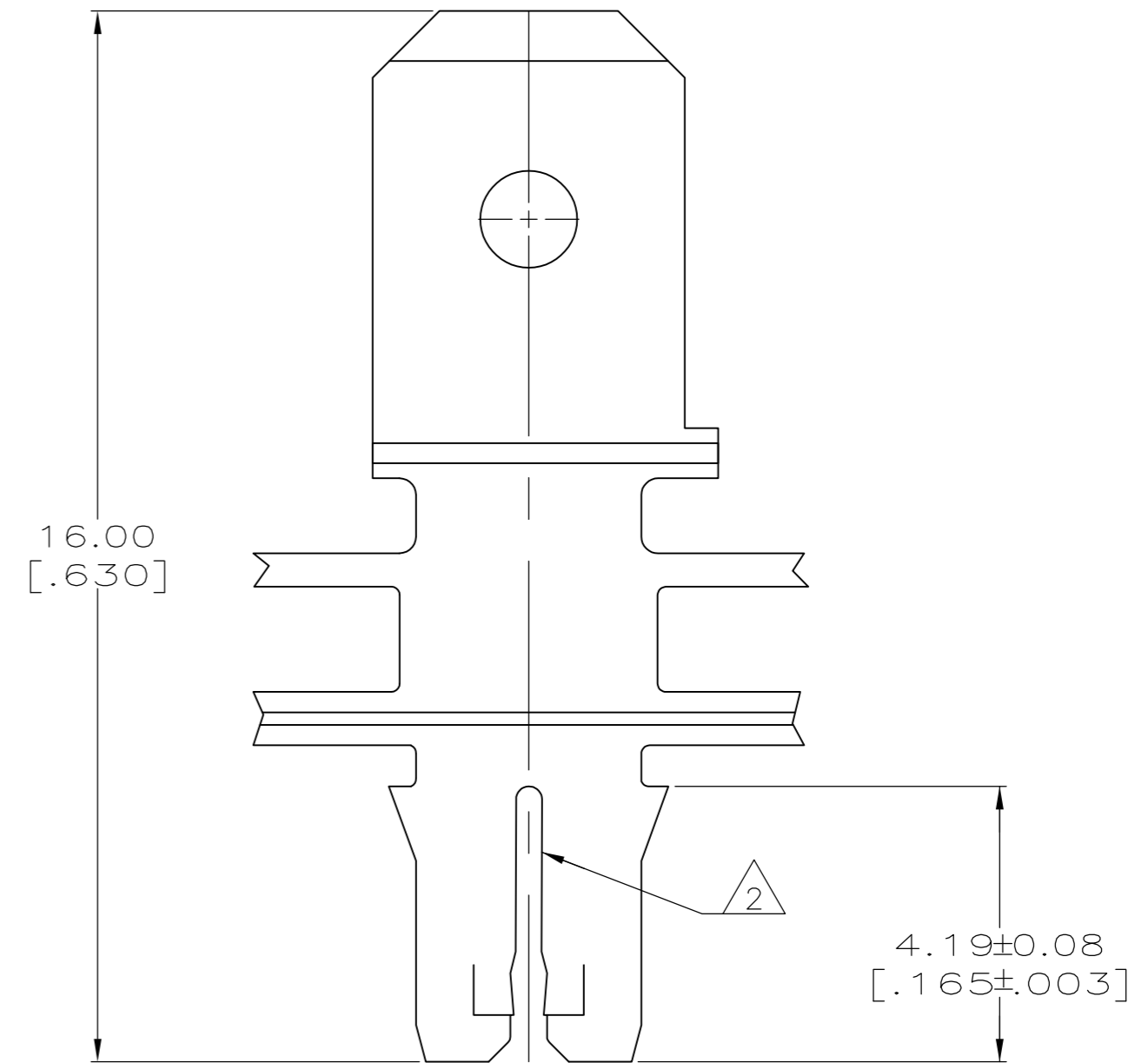
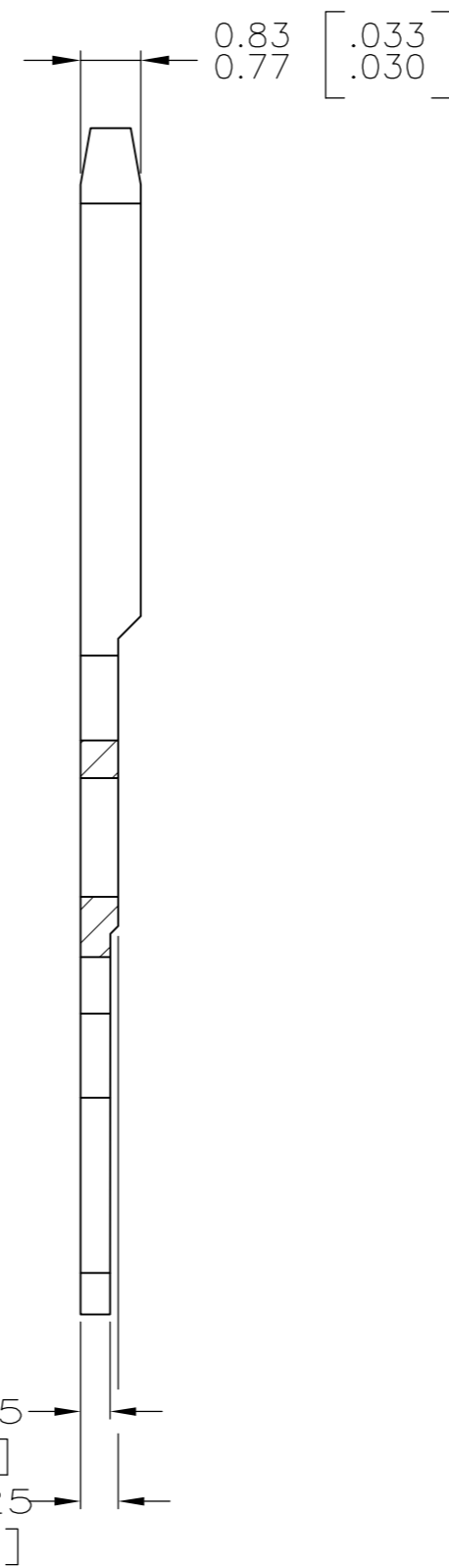
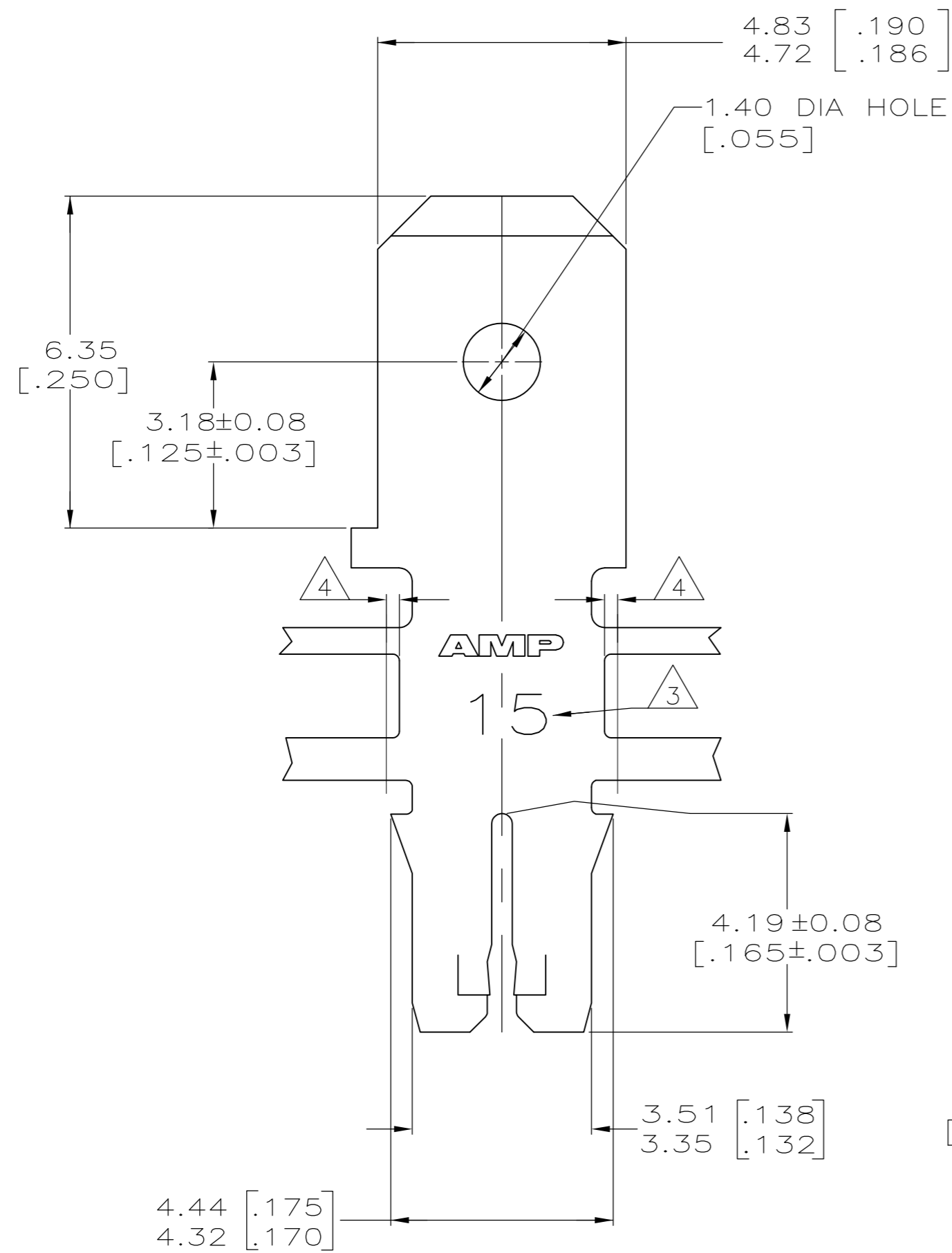

1217516-1
PART NUMBER

THIS DRAWING IS A CONTROLLED DOCUMENT.		DWN MICHAEL S. FEHER 20OCT2000	TE Connectivity																			
DIMENSIONS: mm [INCHES]		CHK KURT A. RANDOLPH 20OCT2000																				
TOLERANCES UNLESS OTHERWISE SPECIFIED:		APVD KURT A. RANDOLPH 20OCT2000	NAME TAB, 4.75[.187] FASTON™ MAG-MATE™ Slim Line																			
<table border="1"> <tr><td>0 PLC</td><td>±</td><td>-</td></tr> <tr><td>1 PLC</td><td>±</td><td>-</td></tr> <tr><td>2 PLC</td><td>±</td><td>0.13[.005]</td></tr> <tr><td>3 PLC</td><td>±</td><td>-</td></tr> <tr><td>4 PLC</td><td>±</td><td>-</td></tr> <tr><td>ANGLES</td><td>±</td><td>-</td></tr> </table>		0 PLC	±	-	1 PLC	±	-	2 PLC	±	0.13[.005]	3 PLC	±	-	4 PLC	±	-	ANGLES	±	-	PRODUCT SPEC 108-1484	SIZE A2	CAGE CODE 00779
0 PLC	±	-																				
1 PLC	±	-																				
2 PLC	±	0.13[.005]																				
3 PLC	±	-																				
4 PLC	±	-																				
ANGLES	±	-																				
MATERIAL BRASS		FINISH TIN PLATE	DRAWING NO 114-2140	DRAWING NO C=1217516																		
		WEIGHT -	SCALE 10:1	SHEET 1 OF 1																		
		CUSTOMER DRAWING	REV D1	RESTRICTED TO -																		