

CODE NO.	CONTACT	A	B	C	D	E	F	G	H
CL0683-0062-4-57	20	10	6.8	5.5	4.5	9.8	8.2	10.4	7.6
CL0683-0063-7-57	30	12.5	9.3	8	7	12.3	10.7	12.9	10.1
CL0683-0064-0-57	40	15	11.8	10.5	9.5	14.8	13.2	15.4	12.6
CL0683-0065-2-57	50	17.5	14.3	13	12	17.3	15.7	17.9	15.1
CL0683-0066-5-57	60	20	16.8	15.5	14.5	19.8	18.2	20.4	17.6
CL0683-0067-8-57	70	22.5	19.3	18	17	22.3	20.7	22.9	20.1
CL0683-0068-0-57	80	25	21.8	20.5	19.5	24.8	23.2	25.4	22.6

NOTES 1 LEAD CO-PLANARITY INCLUDE REINFORCED METAL FITTINGS SHALL BE 0.1mm MAX.
 2 WATCH NOT LET THE CONTACTS TOUCH THE SECTION ESPECIALLY WHEN THE PADS OF AREA NOT RESIST FINISHED.

MATED HEIGHT(h)		(mm)
HEADER NO.	RECEPTACLE NO.	
	DF17#(4.0)-*DS-0.5V(57)	
DF17#(2.0)-*DP-0.5V(57)		6
DF17#(4.0)-*DP-0.5V(57)		8

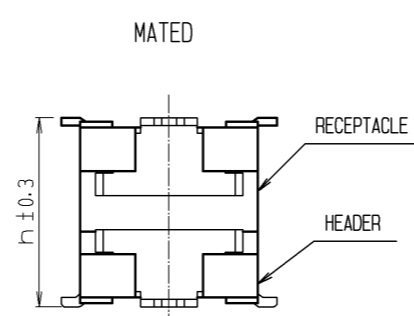

NO.	MATERIAL	FINISH . REMARKS	NO.	MATERIAL	FINISH . REMARKS
2	POLYAMIDE (PA6T)	WHITE BEIGE , UL94V-0	7	PS	CLEAR (REINFORCEMENT COLLAR)
			6	PS	BLACK(PLASTIC REEL)
			5	POLYESTER	CLEAR (COVER TAPE)
1	PHOSPHOR BRONZE	CONTACT AREA : GOLD PLATED 0.1μm min LEAD AREA : TIN PLATED 1μm min UNDER PLATING : NICKEL PLATED 1μm min	4	PS	CLEAR (EMBOSSED CARRIER TAPE)
			3	PHOSPHOR BRONZE	TIN PLATED : 1μm min UNDER PLATING : NICKEL PLATED 1μm min

UNITS	SCALE	COUNT	DESCRIPTION OF REVISIONS	DESIGNED	CHECKED	DATE
mm	5 : 1	△				

APPROVED : KH. IKEDA	11.12.15	DRAWING NO.	EDC3-162133-77
CHECKED : TS. MIYAZAKI	11.12.15	PART NO.	DF17B(4.0)-*DS-0.5V(57)
DESIGNED : YH. MICHIDA	11.12.15	CODE NO.	CL683-
DRAWN : MS. SATO	11.12.14		

STYLE AND DIMENSION OF REEL (FREE)

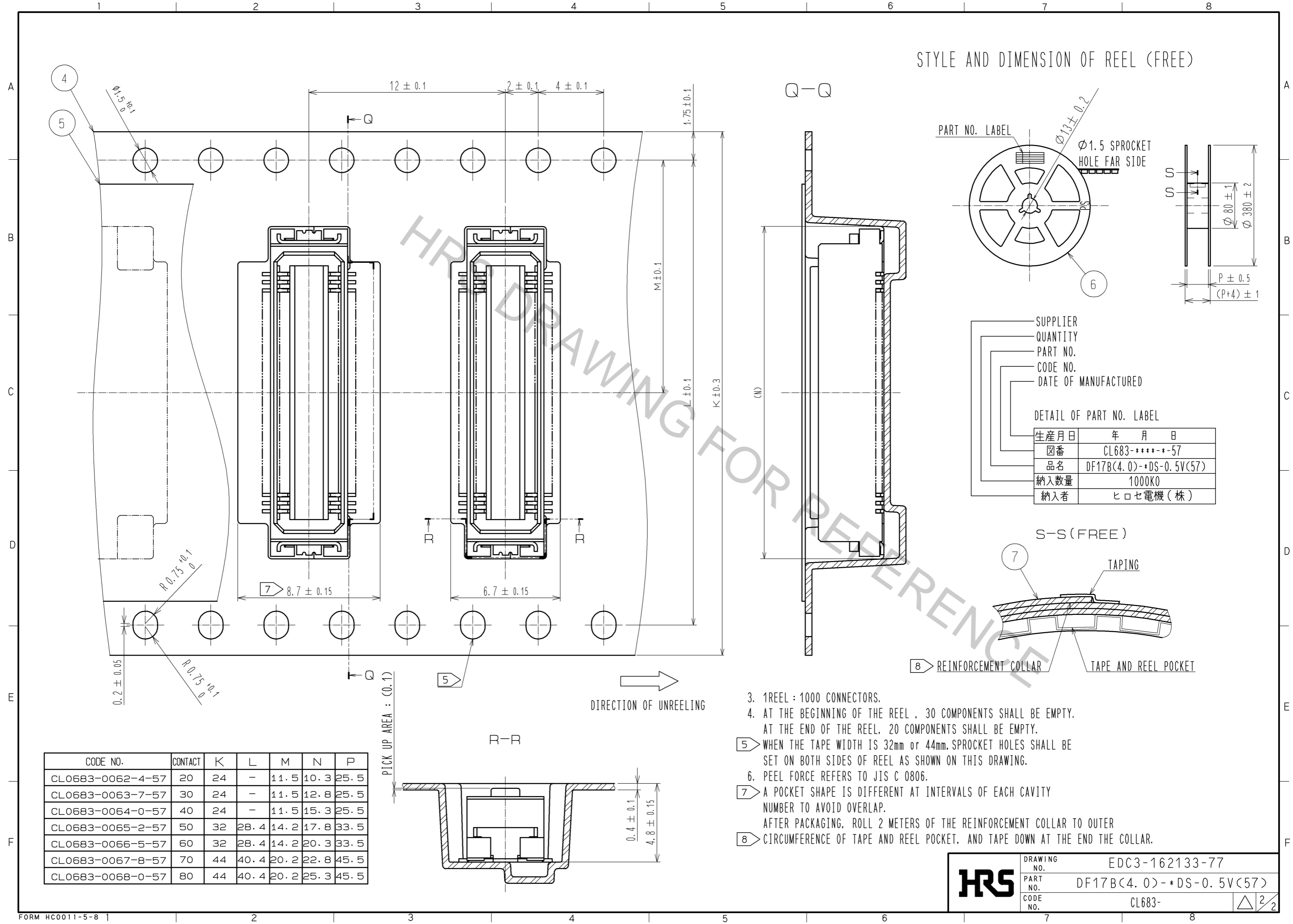

CODE NO.	CONTACT	K	L	M	N	P
CL0683-0062-4-57	20	24	-	11.5	10.3	25.5
CL0683-0063-7-57	30	24	-	11.5	12.8	25.5
CL0683-0064-0-57	40	24	-	11.5	15.3	25.5
CL0683-0065-2-57	50	32	28.4	14.2	17.8	33.5
CL0683-0066-5-57	60	32	28.4	14.2	20.3	33.5
CL0683-0067-8-57	70	44	40.4	20.2	22.8	45.5
CL0683-0068-0-57	80	44	40.4	20.2	25.3	45.5

SUPPLIER
QUANTITY
PART NO.
CODE NO.
DATE OF MANUFACTURED

DETAIL OF PART NO. LABEL

生産月日	年 月 日
図番	CL683-****-57
品名	DF17B(4.0)-*DS-0.5V(57)
納入数量	1000K0
納入者	ヒロセ電機(株)

- 3. 1 REEL : 1000 CONNECTORS.
- 4. AT THE BEGINNING OF THE REEL , 30 COMPONENTS SHALL BE EMPTY. AT THE END OF THE REEL, 20 COMPONENTS SHALL BE EMPTY.
- 5. WHEN THE TAPE WIDTH IS 32mm or 44mm, SPROCKET HOLES SHALL BE SET ON BOTH SIDES OF REEL AS SHOWN ON THIS DRAWING.
- 6. PEEL FORCE REFERS TO JIS C 0806.
- 7. A POCKET SHAPE IS DIFFERENT AT INTERVALS OF EACH CAVITY NUMBER TO AVOID OVERLAP. AFTER PACKAGING, ROLL 2 METERS OF THE REINFORCEMENT COLLAR TO OUTER
- 8. CIRCUMFERENCE OF TAPE AND REEL POCKET, AND TAPE DOWN AT THE END THE COLLAR.

HRS	DRAWING NO.	EDC3-162133-77
	PART NO.	DF17B(4.0)-*DS-0.5V(57)
	CODE NO.	CL683-
		△ 2/2